

MG

The new ZS

New, Bold, Confident



108 VVV
MG RACED GROUP UK



PRESENCE. An MG is not just a car. You should come here only if you're looking for something more than well-insulated transport between points "A" and "B", and determined to find the sort of rewards that only a true driver's car can offer. It's simple really – the new MG ZS is engineered to give a total immersion in driving heaven.





ATTITUDE. Average? Compromise?
Never. The new MG ZS has been designed
and engineered to do more than simply meet
the needs of demanding drivers – it offers a
peerless dynamic experience within its class.

The new MG ZS combines an outstanding driving experience with pavement-stopping looks clearly inspired by the awesome MG XPower SV. It's pure, undiluted MG.





MG is more than a badge. The famous MG octagon is a guarantee, a promise, that the car it is attached to is a genuine, no ifs, no buts, driver's car. The new MG ZS has been designed around these simple principles by a team of genuine enthusiasts. It's not a complicated proposition, yet you'll find the MG ZS offers far more dynamic reward and character than many of its supposedly 'hot' rivals. Maybe they just don't care as much as we do.

But the MG ZS is about more than mere back road prowess. The virtuoso driving experience is underwritten by one of the most advanced suspension systems in its class, meaning outstanding body control in all conditions – wherever you're going. The range of impressive, responsive engines offer all the power necessary to make safe, rapid progress without sacrificing true driving performance. And you'll find a new ergonomically designed cabin, brilliant standard equipment levels and smart, cutting-edge styling.

Pure, 100% MG spirit comes as standard.



EVERY INCH AN MG.

Tough, smart and never afraid of eye contact –
The MG ZS has the looks to back up its performance.



Good news for the new MG ZS's rivals: looks can't kill – but even so the competition is still likely to find itself trembling in the MG ZS's wake thanks to styling that makes absolutely sure that due respect is paid. At the front you'll now find that the MG ZS features svelte, new generation single-unit headlamps, which combine with the deep set bumper and chunky radiator grille to project an unmistakable, forceful presence. The MG ZS features the strong, individual detailing you would expect from an MG, including standard-fit alloy wheels and a sporty, brushed chrome exhaust surround set into the rear bumper. Both saloon and hatchback also feature a discreet lip spoiler at the back, a larger version is optional for those who dare.

Move up a notch to the range-topping MG ZS 180 and things get even more exciting, thanks to a seriously intensive visual workout – and not a steroid in sight. The MG ZS 180's new body kit – optional on other models in the range – brings sporting sill and wheel arch extensions plus the ultra-distinctive 'shark's gills' vents set into the front wings. The MG ZS 180 also sits on meaty 17" alloys. Badging is discreet on all versions – the famous 'MG' octagon gets pride of place front and rear; the MG ZS 180 further distinguished by discreet '180' badges on the front wings. With looks like these there's no need to shout, is there?



COMMAND PERFORMANCE.

Remember those clichés about the excitement of the open road, the thrill of driving? The new MG ZS has a distinctive habit of making them all come true.





Despite its assertive styling, the new MG ZS is not going to magically clear a path through congested streets. What it can do – and does do – is to make life easier; helping to ensure you have all the performance you need when you need it.

The mission here is about always keeping a little something in reserve, ensuring the sort of snarling response you need for safe, no-nonsense overtaking manoeuvres with a range of punchy petrol and responsive diesel engines. Even the entry-point MG ZS 110 is capable of hitting 60mph from rest in just 9.8 seconds. At the top of the tree the MG ZS 180 delivers truly scintillating performance: try knee-trembling figures of just 7.3 seconds from 0 to 60mph, plus a top speed of 139mph, which should be handy if you find yourself on a de-restricted Autobahn. All engines offer smooth, linear responses and excellent levels of refinement, too – for when you're trying to be sensible. And when the road opens up and quiets down you'll find uncompromising purpose – for those moments when it's just you, the road and the distant promise of the horizon.





The relationship between car and driver is always close, but in the new MG ZS it's practically intimate.



HANDLES EVERYTHING.

Suspend disbelief? We suggest that you'd better not – suspension matters more than any other component of a performance car, connecting you to the road and the road to you. And for a true MG driving experience, it becomes highly, obviously relevant. Fortunately the new MG ZS benefits from one of the most advanced suspension systems in its sector – or for that matter, any other. At the front you'll find double wishbones, very similar in principle to those used on the majority of the world's racing cars. Wishbones give extremely accurate control over how the wheel behaves under the forces of acceleration, braking and cornering – or bumps in the road. All this means the maximum amount of grip, smooth transmission of power to the road and uninterrupted steering response. All versions of the MG ZS also come with quick ratio sports steering too, in other words, smooth, accurate responses all the time, under all conditions.

Lowered sports springs help bring the MG ZS's centre of gravity closer to the ground, reducing dive under braking and roll in corners, giving you the opportunity to really experience the drive. Then there are the firm dampers, precision engineered to give outstanding body control and to ensure rough surfaced roads don't get a chance to spoil the dynamic party. We've put vast effort into thinking about the suspension – so that you can enjoy it without having to.





MEET THE TEAM.

Great in corners, brilliant on straights – and rewardingly easy to own, too. MG is a good club to get into.



Choosing could be the tough part, what with the MG ZS's five different engines and both hatchback and saloon body styles to decide between. Tough call. Three versions of the award-winning K Series petrol engine are available, the 1.6 litre unit in the MG ZS 110 with 109Ps, and a 1.8 litre version which does the honours in the MG ZS 120 offering a punchy 117Ps. Plus for those seeking



even more of a performance reserve, the range-topping 2.5 litre KV6 engine in the MG ZS 180 has a sizzling 177Ps of power and performance. Two turbo-diesel engines are on offer with a side-order of exceptional economy to match their performance, in either 101Ps or 113Ps states of tune.

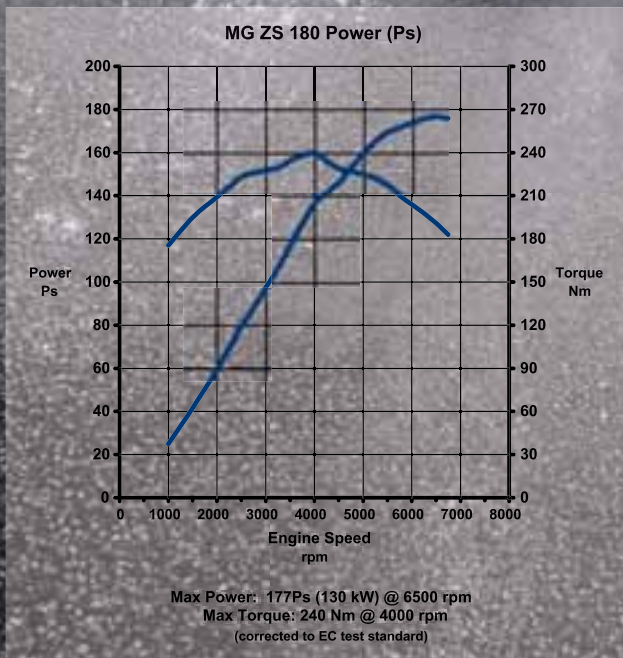

POWER FOR THE PEOPLE.

The engine is far more than just being the heart of an MG.
It's the soul as well.



Performance matters to you? Us too. Every version of the MG ZS comes with an engine capable of providing the kind of serious acceleration and cruising speed you expect from an MG – plus a responsive and rewarding character as well.

With a 1.6 litre version of the outstanding K Series petrol engine, the MG ZS 110 gives decent overtaking punch and excellent fuel economy – plus impressively low emissions. All versions of the K Series benefit from lightweight aluminium alloy construction, ensuring the MG ZS's handling balance remains totally uncorrupted, too.

Next in the range comes the big-hearted MG ZS 120, a consummate all-rounder. With a 1.8 litre K Series engine doing the under-bonnet honours you'll find impressively brisk performance – 0-60mph takes just 9.0 seconds – coupled with impressively low fuel consumption of up to 38.9mpg on the combined cycle. Put it another way, it's extreme fun, yet responsible at the same time, allowing you to be satisfyingly unrestrained.

At the top of the range the MG ZS 180's 2.5 litre KV6 engine shares much technology with its four-cylinder sisters, including lightweight all-alloy construction. There's nothing lightweight about the power output, though: 177Ps, and with a free-breathing 24-valve head this is an engine that loves to be worked hard. Don't worry, there's a tuned sports exhaust to ensure it sounds great too.

As diesel power becomes increasingly popular, so MG broadens the range of available engines. The MG ZS is available with two versions of the brawny L Series turbo diesel, in 101Ps or 113Ps tune. Both combine tremendous amounts of torque – pulling power – with outstanding fuel economy (up to 52.7mpg on the combined cycle for MG ZSTD 101Ps). It's an effortless power delivery perfectly suited to making the most of the MG ZS's agile chassis.



INSIDE, NOW.

Cabin fever? Not a worry with the new MG ZS thanks to a cabin that's as tough, practical and good looking as the rest of the car.



The new MG ZS is all about the thrill of high-performance driving. What it's categorically not about is the irritation of fiddling for small or poorly located buttons. The new dashboard fascia has been ergonomically designed around a real driver's needs. Clear instruments provide all the data you need (and none of the distraction you don't) and controls are positioned in instinctive places. There are also cool new circular air vents in the dashboard, finished in an appropriately MG brushed chrome effect. They work especially well with the new option of ATC 'climate control' air conditioning, keeping you cool, even as the dynamic temperature rises. There is also the smart option of the

brainbox clever SmartNav® satellite navigation system, which allows you to download routes into it. Directions are then given by easy to follow voice instructions, allowing you to concentrate on the more important task of seriously driving your MG ZS.

The fascia comes in a suitably contemporary finish, sporty Technical Grey. The fabric of the standard-fit sports seats come in a range of individual colours and finishes and projects a certain dynamism. There is even the option of Alcantara® and leather trim, perfect for those who like to get their thrills while sitting comfortably.





SPACE RACE.

Brilliant driving dynamics are assured on any MG, but so is an impressive level of practicality. The new MG ZS is, of course, no exception to this principle. A multi-adjustable driver's seat ensures there is a full choice of driving positions, as does a height adjustable steering wheel. The making-life-easier theme continues with our electrically adjustable mirrors on all models and on MG ZS+ models you get the added benefit of electric front windows and air conditioning. Front and rear seat occupants enjoy plenty of space, and generous support from the standard-fit sports seats. And if you find yourself with stuff to move rather than apexes to kiss, don't worry: the MG ZS is happy to roll up the sleeves of its racing overalls. Rear seats fold in a 60:40 configuration – and both hatchback and saloon versions offer excellent luggage space.





MG ZS EXTERIOR COLOURS

COLOURING IN.

**It's a great feeling,
making a car your own.**

A wide range of colour and trim options make it easy to personalise the new MG ZS around your own specifications. There are ten exterior colours to choose between, ranging from old favourites such as British Racing Green to the ultra-modern look of XPower Grey. And that's without considering the interior trim options. Colours and textures have been chosen to match the driving experience of the car – characterful without becoming brash. It's about looking good, not shouting.



FIREFROST (PEARLESCENT)



XPOWER GREY (METALLIC)



ROYAL BLUE (PEARLESCENT)



STARLIGHT SILVER (METALLIC)



IGNITION BLUE (PEARLESCENT †)



RIO RED †



TROPHY YELLOW



GOODWOOD GREEN (PEARLESCENT)



BRITISH RACING GREEN (PEARLESCENT)



BLACK PEARL (PEARLESCENT)

† Please consult your MG Distributor for availability details.

MG ZS INTERIOR COLOURS

GREY MATRIX
Grey/Black Matrix
with Grey Stitching



GREY AXIS/PART LEATHER
Grey/Black Axis with
Grey stitching



BLACK LEATHER



GREEN MATRIX
Green/Black Matrix
with Green stitching



GREEN AXIS/PART LEATHER
Green/Black Axis with
Green stitching



GUNSMOKE ALCANTARA®



BLUE MATRIX
Blue/Black Matrix
with Blue stitching



BLUE AXIS/PART LEATHER
Blue/Black Axis with
Blue stitching



Fabric	Standard on MGZS & MGZS+ Models			Standard on MGZS 180 Models Available as Option on MG ZS+ Models			Available as Option on MG ZS+ & MG ZS 180 models	
	Matrix	Matrix	Matrix	Axis	Axis	Axis	Sports Leather	Alcantara®
Colour	Grey/Black with Grey stitching	Green/Black with Green stitching	Blue/Black with Blue stitching	Grey/Black with Grey stitching	Green/Black with Green stitching	Blue/Black with Blue stitching	Black leather facings	Gunsmoke
Side Bolsters	Black	Black	Black	Black Leather	Black Leather	Black Leather	Black Leather	Black Leather
Door Casing Inserts	Black	Green	Blue	Black	Black	Black	Black	Black
Exterior Colours								
Rio Red*	■			■			■	■
Trophy Yellow	■			■			■	■
Black Pearl	■			■			■	■
Starlight Silver	■			■			■	■
Goodwood Green		■			■		■	■
Royal Blue			■			■	■	■
British Racing Green		■			■		■	■
Firefrost	■			■			■	■
XPower Grey	■			■			■	■
Ignition Blue*			■			■	■	■

■ Recommended combination * Please consult with your MG Distributor for availability details.
Alcantara® is a registered trade mark of ALCANTARA® S.p.A

MG ZS ALLOYS

Tyre sizes

15" 'Mirage' 195/60 R15 tyres

16" 'Hairpins' 205/50 R16 tyres

17" 'Straights' 205/45 R17 tyres

17" '11-Spoke' 205/45 R17 tyres



17" 'Straights'



16" 'Hairpins'



15" 'Mirage'

17" '11 Spoke'

	MG ZS 110 models	MG ZS 120 and ZS TD models	MG ZS 180
15" x 6 'Mirage' alloy wheels with 195/60 R15 tyres	■	-	-
16" x 6.5' Hairpins' alloy wheels with 205/55 R16 tyres	-	■	-
17" x 7 'Straights' alloy wheels with 205/45 R17 tyres	-	□	-
17" x 7.5' 11-Spoke' alloy wheels with 205/45 R17 tyres	-	□†	■
ITR*	■	■	■
15" x 3.5 space-saver spare wheel with 125/80 R15 tyre	□	□	□††

■ Standard □ Optional * ITR is a temporary Instant Tyre Repair system

† 17" 11-Spoke alloys available on MG ZS+120, MG ZS+TD and MG ZS+ 115 TD as part of Body Kit Pack

†† the space saver spare wheel will not fit onto the front hub of the ZS 180, please consult your MG Distributor for fitment details.

KEEPING CONTACT.

Every MG ZS comes with standard-fit alloy wheels and grippy low profile tyres. You could never deny that they look great (and we would have to agree), but they are also strong, ultra-tough and lightweight, the perfect accompaniment to the MG ZS's taut, sporty chassis.

Four styles of alloy are available, from the 15-inch Mirage fitted to the MG ZS 110, the 16-inch Hairpins, and the imposing 17-inch Straights. The 17-inch 11-Spoke alloys are charged with the tough job of filling the MG ZS 180's muscular wheel-arches.

LET US ENTERTAIN YOU.



Single Slot CD Player



Daytona MP53



Lausanne CD33

Favourite road, favourite sounds – no better partnership. With a proper selection of In Car Entertainment options the MG ZS always sounds great. MG ZS+ models come with a CD-Tuner, whilst the 180 models get a CD autochanger. And audiophiles can find even

more choice on the upgrade list, including a CD multichanger or an MP3-compatible head unit that allows you to fit approximately 10 albums' worth of high quality music onto a single CD – and the display screen will even tell you which track it's playing.

MG ZS IN CAR ENTERTAINMENT

	MG ZS models	MG ZS+ models	MG ZS 180
Distributor fit Audio			
Short roof mounted rod aerial	■	■	■
Four speakers – two front, two rear	■	■	■
Two tweeters, one mounted in each front cheater panel	■	■	■
Radio cassette player with AM, FM and RDS	■	□	■
CD-Tuner with AM, FM and RDS	□	■	□
High power CD- Tuner with MP3 facility	□	□	□
6-disc CD autochanger	□	□	■
Factory fit option			
In-dash satellite navigation system including CD player and tuner (CD autochanger is not compatible or provided with this option)	-	□	□

■ Standard □ Optional – Not available

KRC-394



KDC-4024



KDC-M4524



Distributor fit Kenwood ICE

Comprises a range of head units available to all MG ZS models. The table above shows which is the standard unit within the vehicle list price and is a Distributor fit No Cost Option. The remaining units are all available as upgrade options.

Functionality	Radio / Cassette KRC-394	Single Slot CD / Tuner KDC-4024	Single Slot CD / MP3 / Tuner KDC-M4524	6-Disc CD Autochanger KDC-C467
Power Output (max)	4x45 W	4x50 W	4x50 W	
Full logic auto reverse cassette deck	■	-	-	-
Track search & blank skip system	■	-	-	-
CD-R / CD-RW compatible	-	■	■	■
Autochanger compatible	■	■	■	-
Detachable Face plate with carry case	■	■	■	-
CD text display	-	-	■	-
Radio text	-	■	■	-
RDS with EON – PTY	■	■	■	-
System Q – easy sound adjust	■	■	■	-
Pre outs (for connection of Amplifier)	1	1	1	-

■ Standard □ Optional - Not Available

MG ZS KEY STANDARD FEATURES

Interior

- Sports styled and shaped seats
- Matrix fabric seat facings (Grey, Blue or Green colourways)
- Technical Grey fascia inserts and console/switch surrounds
- Rotary styled air vents with satin chrome finish
- Silver-finish instrument dials with orange needles
- Alloy and leather gearknob
- Sports steering wheel with MG badge
- Driver's heel mat and left footrest
- Driver's sunvisor pocket
- Passenger's sunvisor with vanity mirror
- Cloth headlining with one front and two rear grab handles
- Lockable glovebox with lamp
- Front door bins
- Console stowage tray with rubber mat
- Front and rear ashtrays
- Auxiliary power socket
- Driver's cubby box
- Centre console cubby box with lid, removable cupholders and pen clip
- Driver's seat height and lumbar adjustment
- 60/40 split folding rear seat
- Carpeted loadspace

Instruments and Controls

- Tilt adjustable steering column
- LCD odometer/tripmeter
- Rev counter
- Low fuel warning lamp
- Low coolant level warning lamp
- Door/boot open warning light

Audio

- 4 x 45w Kenwood radio cassette
- 6 Speakers (two front, two rear and two front tweeters)

Body and Exterior Features

- MG styled front grille
- Deep front bumper incorporating integrated lip spoiler and mesh grille
- Rear tailgate/bootlid integrated lip spoiler
- Body-coloured front and rear bumpers
- Body-coloured sill finishers
- Body-coloured door mirrors, door handles and side mouldings
- Green-tinted glass
- Large bore exhaust and exhaust heatshield (except ZS 110 and ZS+ 110)
- White rear lamp lenses
- MG tailgate/bootlid badge
- Rear MG ZS badge
- Chequered flag and Union flag badges on D posts
- Clear lens twin halogen headlamps
- Clear side repeater lamps
- 16" Hairpins alloys (except ZS 110 and ZS+ 110)
- Instant Tyre Repair system

Electrical Features

- Powered door mirror adjustment with heating
- Single front centrally mounted interior lamp with 'wake up' and delay functions
- Glove compartment, loadspace and ashtray lamps
- Electric headlamp levelling
- High centrally mounted rear brake lamp
- Lights-on warning buzzer
- Heated rear screen with timed switch-off
- Two-speed wipers with intermittent wipe
- Rear wash-wipe with intermittent and automatic operation in reverse (5-door only)

Locks and Security

- Remote central door locking
- Plip controlled remote boot release function
- Internal tailgate/boot release
- Internal fuel filler flap release
- Security wheel nuts (one per wheel)
- Thatcham Category 1 alarm system with perimeter and volumetric protection
- Passive engine immobilisation
- Visible second VIN label
- Security shielding for steering column, all doors and tailgate locks
- Auto-relocking and speed locking functions
- Master locking/unlocking switch including personal panic attack alarm mode
- Childproof rear door locks

Heating and Ventilation

- Air blending heater unit with 4-speed blower, re-circulation control, side window demist

Suspension and Steering

- Low ride height
- Sports springs and dampers
- Front and rear anti-roll bars
- Sports tuned power steering
- Quick ratio steering rack

Unique MG ZS 110 and MG ZS+ 110 Features

- 15" Mirage alloy wheels
- Concealed rear exhaust, no rear exhaust heatshield

MG ZS+ models Additional Specification

- CFC-free on/off air conditioning including pollen filter
- Electric front windows with driver's one-shot open
- Leather steering wheel
- 4 x 50w Kenwood CD-Tuner

MG ZS 180 Additional Specification over ZS+ models

- Large front and rear disc brakes (282mm front, 260mm rear)
- Sports ratio gearbox with modified linkages and short throw gearshift
- Axis fabric seat facings with horizontal fluting and leather side bolsters (Grey, Blue or Green colourways)
- Leather gear lever gaiter
- Front fog lamps
- 180 badge mounted on side fender
- Automatic temperature control air conditioning
- 4 x 45w Kenwood radio cassette
- 6-disc CD autochanger
- Front and rear wheel arch spats
- Integrated side sill finisher
- Front fender vents
- 17" 11-Spoke alloys



If you want your **MG** to reflect your tastes.
If you want it to take on a little of your personality.
If you want it to be bespoke.
Take a close look at our **Monogram** programme.



Be yourself

monogram



Now your car becomes you.



MONOGRAM GIVES EVERYONE THE OPPORTUNITY TO PERSONALISE THEIR CAR AND REALLY STAND OUT FROM THE CROWD. **BY CHOOSING FROM THE MONOGRAM RANGE, YOUR NEW MG ZS CAN REFLECT YOUR TASTE AND PERSONALITY – FROM THE EYE - CATCHING EXTERIOR COLOUR AND FINISH OF THE BODYWORK AND INTERIOR TRIM. YOU CAN CREATE A CAR THAT'S AS INDIVIDUAL AS YOU ARE.**

Be you.





MONOGRAM EXTERIOR

MONOGRAM OFFERS A PALETTE OF STYLE-AWARE AND TECHNICALLY ADVANCED EXTERIOR PAINT FINISHES. YOUR CHOICE CAN SPEAK QUIETLY AND CONFIDENTLY OR YOU CAN OPT FOR BOLDER, BRIGHTER BRUSH STROKES. COLOUR IS A LIVING THING AND MONOGRAM INVITES YOU TO BRING YOUR MG VERY MUCH TO LIFE.

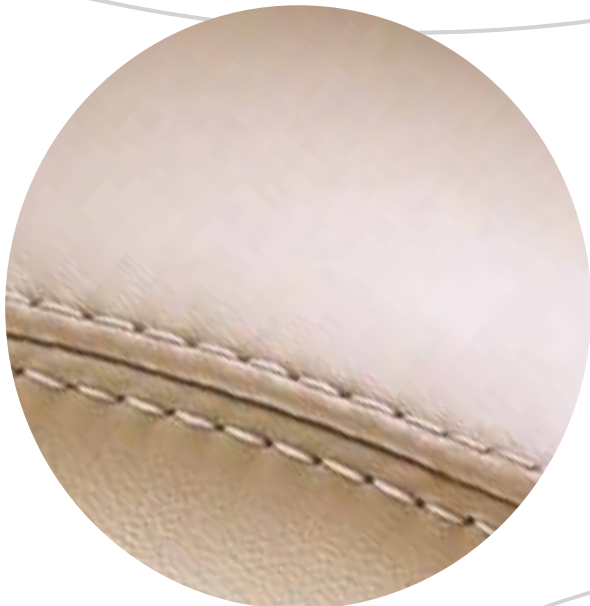

MONOGRAM INTERIOR

IF YOUR CAR'S EXTERIOR SPEAKS TO OTHERS, THEN THE INTERIOR IS YOUR PERSONAL DOMAIN. HERE IS WHERE YOU FEEL AT ONE WITH YOUR DRIVING ENVIRONMENT; HERE IS WHERE YOU ARE IN CONTROL. OUR MONOGRAM INTERIOR FINISHES RANGE FROM THE DARINGLY SPORTY TO THE DOWNRIGHT LUXURIOUS. CHOOSE A MONOGRAM INTERIOR AND YOU WILL SOON BE DRIVING IN THE STYLE TO WHICH YOU WISH TO BECOME ACCUSTOMED.



MONOGRAM OPTIONS

THE MONOGRAM PERSONAL OPTIONS PROGRAMME CAN MEAN STATE-OF-THE-ART IN CAR ENTERTAINMENT SYSTEMS. OPTIONS CAN ALSO MEAN COMPUTER-AIDED NAVIGATION SYSTEMS THAT HELP GUIDE YOU SMOOTHLY TO YOUR NEXT VITAL APPOINTMENT. OR HOW ABOUT ELECTRIC SEATS OR ALLOY WHEELS – OR ANY OF A RANGE OF MOTORING REFINEMENTS THAT MAKE TRAVELLING A PLEASURE.

MG ZS VITAL STATISTICS

ENGINES

		MG ZS TD Man	MG ZS TD 115 Man	MG ZS 110 Man	MG ZS 120 Man	MG ZS 120 Stepspeed	MG ZS 180 Man
Engine type		2.0 turbo diesel	2.0 turbo diesel	1.6 dohc 16v petrol	1.8 dohc 16v petrol	1.8 dohc 16v petrol	2.5 V6 quad cam petrol
cc		1994	1994	1589	1796	1796	2497
Maximum power	Ps	101	113	109	117	117	177
	@ rpm	4200	4200	6000	5500	5500	6500
Maximum torque	Nm	240	260	138	160	160	240
	@ rpm	2000	2000	4500	2750	2750	4000
Max. engine speed	rpm	4500	4500	6800	6800	6000	6750

PERFORMANCE

		MG ZS TD Man	MG ZS TD 115 Man	MG ZS 110 Man	MG ZS 120 Man	MG ZS 120 Stepspeed	MG ZS 180 Man
0-60mph	(secs)	10.3	9.5	9.8	9.0	9.9	7.3
30-50mph in 4th	(secs)	6.8	6.6	8.4	6.8	-	6.0
50-70mph in 4th	(secs)	7.4	6.7	9.3	7.6	-	6.0
Top speed	(mph)	116	120	119	122	115	139

FUEL ECONOMY

		MG ZS TD Man	MG ZS TD 115 Man	MG ZS 110 Man	MG ZS 120 Man	MG ZS 120 Stepspeed	MG ZS 180 Man
Urban cycle	(mpg)	38.7	36.2	30.1	29.2	23.8	20.0
Urban cycle	(l/100km)	7.3	7.8	9.4	9.7	11.9	14.1
Extra-urban	(mpg)	66.4	65.7	50.1	48.3	43.2	41.4
Extra-urban	(l/100km)	4.3	4.3	5.6	5.8	6.5	6.8
Combined	(mpg)	52.7	50.5	40.2	38.9	33.3	29.7
Combined	(l/100km)	5.4	5.6	7.0	7.3	8.5	9.5
CO ₂	(g/km)	150	150	168	174	203	227

GEAR RATIOS

	MG ZS TD Man	MG ZS TD 115 Man	MG ZS 110 Man	MG ZS 120 Man	MG ZS 120 Stepspeed	MG ZS 180 Man
5th	0.649	0.649	0.878	0.765	(Max.0.443)	0.765
4th	0.848	0.848	1.108	1.033		1.033
3rd	1.222	1.222	1.414	1.308		1.308
2nd	1.895	1.895	2.038	1.842		1.842
1st	3.250	3.250	3.583	3.167	(Min.2.416)	3.167
Reverse	3.000	3.000	3.615	3.000	2.658	3.000
Final drive ratio	3.938	3.938	3.824	4.200	4.05 x 1.423 drop gear	3.938
Maximum mph per 1000 rpm	27.2	27.2	20.8	21.7	26.6	23.2

MG ZS 4 & 5 DOOR - VEHICLE WEIGHT

	110 [1.6] man		120 man		120 Stepspeed		180 man		Turbo Diesel man	
	Kg	lb	Kg	lb	Kg	lb	Kg	lb	Kg	lb
unladen minimum, see note 1	1105	2435	1125	2480	1150	2535	1235	2720	1230	2710
unladen maximum, see note 1	1205	2655	1215	2675	1240	2730	1285	2830	1325	2920
max laden weight, see note 2	1640	3615	1640	3615	1640	3615	1720	3790	1720	3790
max axle load, front	845	1860	845	1860	845	1860	940	2070	940	2070
max axle load, rear, see note 2	840	1850	840	1850	840	1850	840	1850	840	1850
max roof load	65	140	65	140	65	140	65	140	65	140
max trailer weight, unbraked	500	1100	500	1100	500	1100	500	1100	500	1100
max trailer weight, braked, see note 3	1000	2205	1000	2205	1000	2205	1000	2205	1000	2205
max tow hitch download	70	150	70	150	70	150	70	150	70	150

Note

- 1) Unladen weight is with no occupants and 90% fuel tank filling.
- 2) When towing, the vehicle max laden weight can be increased by up to 100kg(221lbs) and the maximum rear axle load can be increased by 15%, provided road speed is limited to a maximum of 62mph(100km/h).
- 3) The maximum towing weights shown above are to an industry defined standard and represent the maximum weight that can be towed by the vehicle, allowing it to restart efficiently on a 12% gradient (1 in 8.3 approx.) at sea level. Always fit MG Rover officially approved towing attachments and accessories, available from your distributor. These are the only ones approved for use on MG Rover cars.

MG ZS 180 GEARING

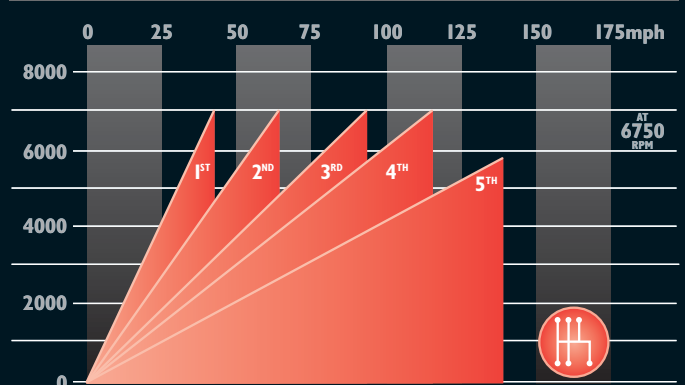

MG ZS 180 FUEL

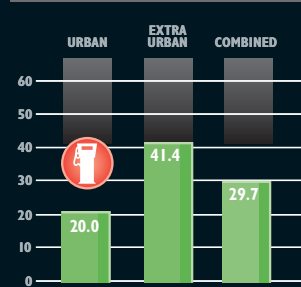

ECONOMY MPG

Tank capacity: 12.1 Gallons (55 Litres)

MG ZS 180 POWER

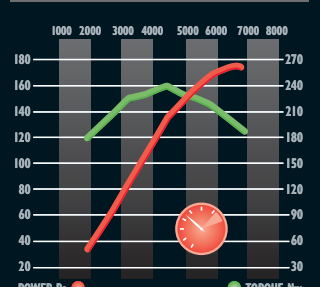

MG ZS POWER - TORQUE

Manufacturer's data. All fuel economy figures are in accordance with Directive 99/100/EC. They have been calculated using the same test cycle as used for official exhaust emission classification. They cannot be compared with the previous steady speed/urban figures and are more representative of actual on-road fuel consumption. Under normal use a car's actual fuel consumption figures may differ from those achieved through the test procedure, depending on driving technique, road and traffic conditions, environmental factors, and vehicle condition.

Please ask your MG Distributor for details about the full range and benefits of our approved LPG conversion.

MG ZS DIMENSIONS

		MG ZS models without body styling kit		MG ZS 180 and all other models with optional body styling kit	
		5 dr	Saloon	5 dr	Saloon
Overall vehicle length	mm	4386	4540	4386	4540
Overall vehicle width (including mirrors)	mm	1923	1923	1923	1923
Width excluding door mirrors	mm	1678	1678	1727	1727
Overall height	mm	1386	1386	1386	1386
Wheelbase	mm	2620	2620	2620	2620
Front overhang	mm	868	868	868	868
Rear overhang	mm	898	1052	898	1052
Front track	mm	1475	1475	1475	1475
Rear track	mm	1465	1465	1465	1465
Boot capacity (rear seat up)	litres VDA	370	470	370	470
Load capacity (rear seat down)*	litres VDA	920	930	920	930

* Below parcelshelf and window line

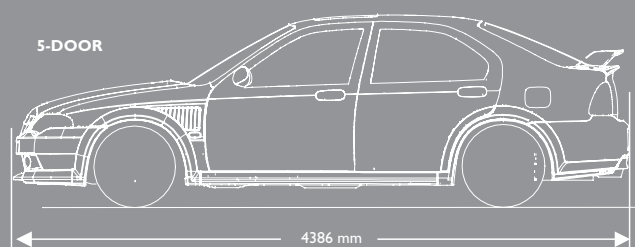
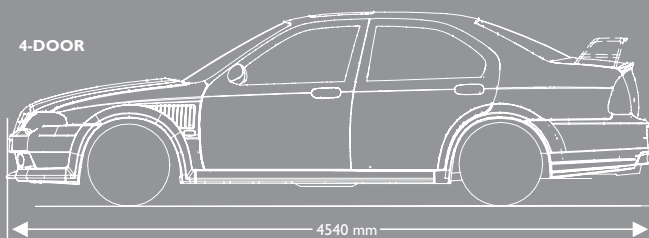
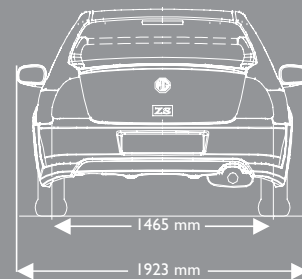
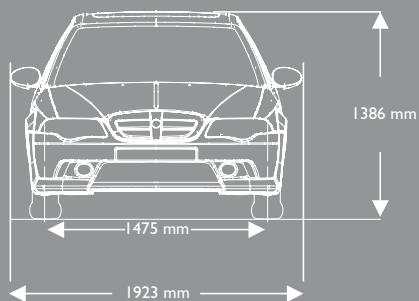

4-DOOR – Internal Dimensions: Front legroom 1.06m max. Rear legroom 0.85m min. Front headroom 0.94m. Rear headroom 0.93m. Front shoulder room 1.34m. Rear shoulder room 1.34m.
5-DOOR – Internal Dimensions: Front legroom 1.06m max. Rear legroom 0.83m min. Front headroom 0.94m. Rear headroom 0.92m. Front shoulder room 1.34m. Rear shoulder room 1.34m.



MG ZS VITAL STATISTICS

MG ZS 110
MG ZS+ 110
4 & 5dr

MG ZS 120
MG ZS+ 120
4 & 5dr

MG ZS
120 Stepspeed
MG ZS+
120 Stepspeed
4 & 5dr

MG ZS+
TD
4 & 5dr

MG ZS+
115TD
4 & 5dr

MG ZS 180
4 & 5dr

Insurance Groups (ABI recommended)

All models are Thatcham Category I security rated

TBC*

TBC*

TBC*

TBC*

TBC*

TBC*

* Insurance groups are unavailable at the time of printing; please consult your Distributor.

Engines and Transmissions

K Series 1.6 16v dohc	■	-	-	-	-	-
K Series 1.8 16v dohc	-	■	■	-	-	-
LPG Dual Fuel**	□	□	-	-	-	-
TCie 2.0 intercooled direct injection turbodiesel	-	-	-	■	■	-
KV6 24-valve quad cam 2.5 litre	-	-	-	-	-	■
Five-speed manual transmission	■	■	-	■	■	■
Sports ratio gearbox with short-throw gearshift	-	-	-	-	-	■
EmCVT Stepspeed transmission	-	-	■	-	-	-

** Please ask your MG Distributor for details of approved LPG conversions.

Brakes

Solid front disc brakes	■	-	-	■	-	-
Ventilated front disc brakes	-	■	■	-	■	-
Uprated ventilated front disc brakes (282mm)	-	-	-	-	-	■
Rear drum brakes	■	-	-	■	-	-
Rear disc brakes	-	■	■	-	■	-
Uprated rear disc brakes (260mm)	-	-	-	-	-	■
Four-channel ABS	■	■	■	■	■	■
Electronic brakeforce distribution	■	■	■	■	■	■

Suspension

	MG ZS models	MG ZS+ models	MG ZS 180
Low ride height	■	■	■
Sports springs and dampers	■	■	■
Double wishbone front suspension	■	■	■
Multilink rear suspension	■	■	■
Front anti-roll bar	■	■	■
Rear anti-roll bar	■	■	■

Steering

Sports tuned power steering wheel	■	■	■
Quick ratio steering rack	■	■	■

Safety

Laminated windscreen	■	■	■
Driver's, passenger's and front side (thorax) airbags	■	■	■
Door side intrusion beams	■	■	■
Adjustable front head restraints	■	■	■
Height adjustable front seat belts with pretensioners and load limiters	■	■	■
Three lap and diagonal inertia reel seat belts (saloons)	■	■	■
Two inertia reel lap and diagonal seat belts with centre lap belt (5-door models)	■	■	■
High mounted rear brake lamp. Twin rear fog guard lamps	■	■	■
ABS with electronic brakeforce distribution	■	■	■
Rear door child safety locks	■	■	■
Inertia switch controlling fuel isolation and door unlocking	■	■	■

Locks and Security

'Thatcham 1' grade perimetric and volumetric alarmed protection system	■	■	■
Passive engine immobilisation	■	■	■
Battery backed-up alarm sounder	■	■	■
Remote controlled central door locking	■	■	■
Audible mislock sounding	■	■	■
Internal master locking switch with personal alarm function	■	■	■
Passive relocking function	■	■	■
Speed dependent locking function	■	■	■
Boot/tailgate release facility through plip or internal release	■	■	■
Internal bonnet release. Internal fuel filler flap release	■	■	■
Shielded steering column and door locks	■	■	■
Visible second VIN plate	■	■	■
Security wheel nuts (one per alloy wheel)	■	■	■
Trackstar tracking system	-	□	□

Heating and Ventilation

Air blending fresh air system with recirculation mode	■	■	■
Air flow to front and rear footwells and front side windows	■	■	■
Four rotary face level vents	■	■	■
Rotary controls for four-speed fan and air distribution	■	■	■
Manual air conditioning. Pollen filter	-	■	-

MG ZS VITAL STATISTICS

	MG ZS models	MG ZS+ models	MG ZS 180
Heating and Ventilation (continued)			
ATC (automatic temperature control) air conditioning with constant interior temperature regulation, solar heat sensor, automatic selection of air source and distribution, variable fan speed and pollen filter	–	□	■
Heated rear window with timed off function	■	■	■
Interior			
Sports shaped and styled seats	■	■	■
Matrix seat fabric in a choice of colours	■	■	–
Axis seat fabric in a choice of colour with black leather bolsters	–	□	■
Gunsmoke Alcantara® seat facings with black leather bolsters	–	□	□
Perforated leather steering wheel	–	■	■
Leather and alloy manual gearknob	■	■	■
Leather gear lever gaiter	–	–	■
Front seat fore-aft and recline adjustments	■	■	■
Driver's height and lumbar adjustment	■	■	■
Fully trimmed doors with cloth inserts and integrated door pulls/armrests	■	■	■
Fully carpeted car interior and boot	■	■	■
All-Ash interior colourway	■	■	■
Technical Grey fascia and console finishers	■	■	■
60/40 split folding rear seatback	■	■	■
Forward folding rear seat cushion on 5-door models	■	■	■
Bright front door sill tread strips	■	■	■
Glovebox with lock and illumination. Rear ashtray. Front door bins	■	■	■
Centre console oddments tray with mat. Driver's drop-down cubby box	■	■	■
Full length high centre console with lidded box incorporating removable cup holders and pen clip module	■	■	■
Passenger grab handles. Dipping rear view mirror	■	■	■
Twin swivelling sunvisors with passenger's vanity mirror and driver's docket pocket	■	■	■
Driver's heel mat and left foot rest. Rear seat belt tidy stowage facility	■	■	■
Satin chrome fresh air vent surrounds. Chrome interior door release handles	■	■	■
Instruments and Controls			
Tilt adjustable steering column	■	■	■
Silver finish dials with orange needles	■	■	■
Rev counter	■	■	■
LCD odometer with trip function	■	■	■
Digital clock	■	■	■
Twin column stalks for indicators, main beam, headlamp flash, two speed wipers, wash-wipe, intermittent wipe and (5-door models) rear wiper and washer	■	■	■
Rear wash-wipe with automatic operation when reversing with front wipers on (5-door models)	■	■	■
MG badged sports steering wheel	■	■	■
Horn buttons in steering wheel centre	■	■	■
Electrical			
Electrically adjustable and heated door mirrors	■	■	■
Electric front windows with driver's one-shot down function	■	■	■
Electric window time-out operation	■	■	■
Courtesy lamp operated by front and rear doors with 'wake up' and timed fade-out functions	■	■	■
Twin halogen headlamps with internal beam level adjuster	■	■	■
Front fog lamps	□	□	■
Twin reversing lamps. Hazard warning lamps. Clear side indicator repeater	■	■	■
Lamps-on warning buzzer. Loadspace lamp	■	■	■
Auxiliary power socket (instead of cigar lighter)	■	■	■
Exterior			
Deep front bumper. Black mesh grilles. Integrated body colour rear lip spoiler	■	■	■
Body colour bumpers, side mouldings, sill finishers and door pulls	■	■	■
Sports body kit featuring sill finishers, wheelarch extensions, front bib and front fender 'vents'	–	–	■
Large bore exhaust (except ZS 110 models)	■	■	■
Body colour door mirror covers	■	■	■
Large body colour rear spoiler (instead of lip spoiler)	□	□	□
Green-tinted glass	■	■	■
Clear lens headlamp pods with integrated front indicator lamps	■	■	■
Choice of metallic and pearlescent paint finishes	□	□	□
MG commission plate	■	■	■
Union and Chequered flag badges	■	■	■
'180' fender badges	–	–	■
Option Packs			
Electric Pack: electric slide/tilt glass sunroof with internal blind, Trafficmaster® Alert and ultrasonic rear parking distance sensors	–	□	□
Body Kit Pack: 17" x 7.5 11-Spoke alloy wheels, sill finishers, wheelarch extensions front bib and front fender 'vents'	–	□	■

■ Standard □ Optional – Not available

Alcantara® is a registered trademark of ALCANTARA® S.p.A.

SAFE AND SECURE.

Safety matters, because let's be honest – it's not getting any less fraught out there. You never know what's around the next corner (or possibly even parked across it) which is why the new MG ZS has been designed to protect you from the unexpected. All versions have driver and front passenger airbags as standard, plus two side airbags. Anti-submarine seats are there to ensure occupants don't slip under the seatbelt in the event of a collision. And to help keep you out of trouble in the first place, the MG ZS comes with both anti-skid ABS braking and electronic brakeforce distribution (EBD) as standard, helping to keep you firmly in control.

And to make sure that pride and joy don't turn to frustration and rage, the MG ZS also comes with an impressive array of security features. The alarm system exceeds the tough standards of the demanding Thatcham-1 criteria. All cars also come with auto-locking, automatically securing the car and activating the alarm after a set period, if left unsecured. And for added reassurance a 'master lock' button secures all the doors immediately – there's even a panic alert system to help attract attention if you really need to. It's your MG ZS, and like you, we want to keep it that way.





All MG Distributors in the UK have factory trained technicians and immediate access to over 70,000 approved parts. They're fully equipped to deal with today's sophisticated MG cars, and offer competitively priced servicing with a guarantee of workmanship on every job they do. With 280 Distributors UK-wide, there is extensive coverage never too far away.

Buying an MG isn't just about satisfying your heart's desire – there are plenty of reassuring features that your head will appreciate too.

● WARRANTY

During the first three years of ownership you'll enjoy the protection of one of the most comprehensive extended warranties in the industry.

All MG models purchased from MG Rover Distributors in the UK are covered by a three year/60,000 mile warranty.* Included within this extended three year warranty is an array of guarantees and services designed to offer complete peace of mind motoring.

Roadside Assistance is provided in the UK for the first year by the Automobile Association whose fleet of 3,500 patrol vehicles provide a service of roadside repair or Homestart. In the event that the vehicle cannot be repaired at the roadside it will be taken to the nearest MG Rover Repairer or to a destination of the customer's choice.

MG Rover customers can purchase AA 5 Star European Services at preferential rates from the Automobile Association and 2nd and 3rd year Roadside Assistance options can be purchased from your supplying Distributor.

● SERVICE INTERVALS

12 months/15,000 miles for petrol models, 12 months/12,000 miles for Turbo Diesel models.

* Made up of 12 month unlimited mileage warranty plus MG Rover's 2nd and 3rd year 60,000 mile extended warranty, subject to terms and conditions. The extended warranty is provided by MG Rover as a no cost option to purchasers of MG's from approved UK MG Rover Distributors. The extended warranty will only apply to the extent that the 12 month unlimited mileage warranty has not exceeded 60,000 miles.

ENVIRONMENTAL STATUS

MG Rover Group Ltd is environmentally accredited to ISO14001 (Environmental Management Systems); meets all necessary vehicle exhaust gas emissions limits for the EU and other relevant markets; and is complying with developing national regulations to meet the waste prevention objectives of the European Directive on End of Life Vehicles (ELVs). For more details on MG Rover's efforts to improve product/site environmental performance, including vehicle recyclability, free take-back networks for ELVs, and other environmental issues, please click on the 'Environment' link in the 'About Us' section of the MG Rover website www.mg-rover.com, or ask your local Distributor for information.



Call MG now on 08459 251 251. Alternatively, visit www.mgcars.co.uk to book a test drive or contact your nearest Distributor.



BY APPOINTMENT
TO HER MAJESTY
THE QUEEN
MANUFACTURERS OF
ROVER AND MG MOTOR CARS
MG ROVER GROUP LTD, LONGBRIDGE



BY APPOINTMENT
TO HRH THE PRINCE OF WALES
MANUFACTURERS OF
ROVER AND MG MOTOR CARS
MG ROVER GROUP LTD, LONGBRIDGE

MG Rover Group
PO Box 41
Longbridge
Birmingham
B31 2TB
www.mgcars.co.uk

© MG Rover Group Ltd 2004.

Important Notice: MG Rover Group is constantly seeking ways to improve the specification, design and production of its vehicles and alterations take place continually. Whilst every effort is made to produce up to date literature, this UK market brochure should not be regarded as an infallible guide to current specifications, nor does it constitute an offer for the sale of any particular vehicle. Distributors are not agents of MG Rover Group and have absolutely no authority to bind MG Rover Group by any express or implied undertaking or representation. Any reference in this brochure to speed or performance should not be taken as an encouragement to drive either dangerously or at speeds in excess of the national limit. If you require any further information regarding MG products or services, please contact your MG Distributor, who will be pleased to assist you.

Publication number: 6227

YOUR LOCAL DISTRIBUTOR IS



LIFE'S TOO SHORT
NOT TO

