

Polestar 3
—
Fleet and business





The SUV for the electric age

The Polestar collection now consists of three models and continues to expand. This is Polestar 3, an electric performance SUV defined by sculpted surfaces, discreet details, and optimised dynamics. The result is a sleeker, more technical SUV, integrating technology, such as the optional LiDAR system, to enhance the driver experience and the thrill of electric driving.

Acceleration from 0 to 100 km/h

4.7 sec

Power up to

380 kW

517 hp

Performance

The dual-motor powertrain delivers 360 kW of power and 840 Nm of torque. The optional Performance pack increases those figures to 380 kW and 910 Nm respectively. Torque vectoring increases turn-in and control, and Brembo brakes are standard for every Polestar 3 for maximum stopping power. The Long range Single motor variant is also available.





Charging speed

DC 250 kW, from 10 to 80%

30 min

AC 11 kW, from 0 to 100%

11 hrs





Inner space

The generous interior space of Polestar 3 is a seamless extension of the exterior design. The electric powertrain creates a flat floor throughout the cabin enhancing the feeling of space. Subtle details and curated materials find room for expression. Ambient lighting highlights vents, foot wells, and tactile door surfaces, to add a sense of luxury felt by every passenger.





Executive 2
100% perforated Nappa leather
AlVig DCC airHD treatment
Personal leather care set

Sustainability by design

When changing the automotive landscape, electrification is a great start. But not enough. For Polestar 3, sustainability begins even before the first drive. Blockchain technology traces minerals used, and upholstery such as leather and wool, are animal welfare traced. A sustainability declaration is even printed on the seats as proof. Recycled materials are included at every opportunity, ensuring the smallest possible footprint and emissions throughout the car's lifecycle.



Zinc Nappa leather with black ash wooden deco.



Jupiter Nappa leather with black ash wooden deco.



Charcoal Nappa leather with black ash wooden deco.



Charcoal Wool with aluminium deco.



Charcoal MicroTech with aluminium deco.



Charcoal WeaveTech with tectonic deco.



Sound experiences

The Bowers & Wilkins for Polestar sound system includes 25 speakers and a total output of 1610 Watts for fully immersive 3D surround sound. Dolby Atmos technology ensures sublime clarity, depth, detail. The High Performance Audio option also uses the Polestar 3 interior to deliver balance and memorable moments in sound. Active road noise cancellation blocks out unwanted frequencies from wind, tyre, and other road noises, but includes necessary noises such as sirens, car horns, and traffic signals.

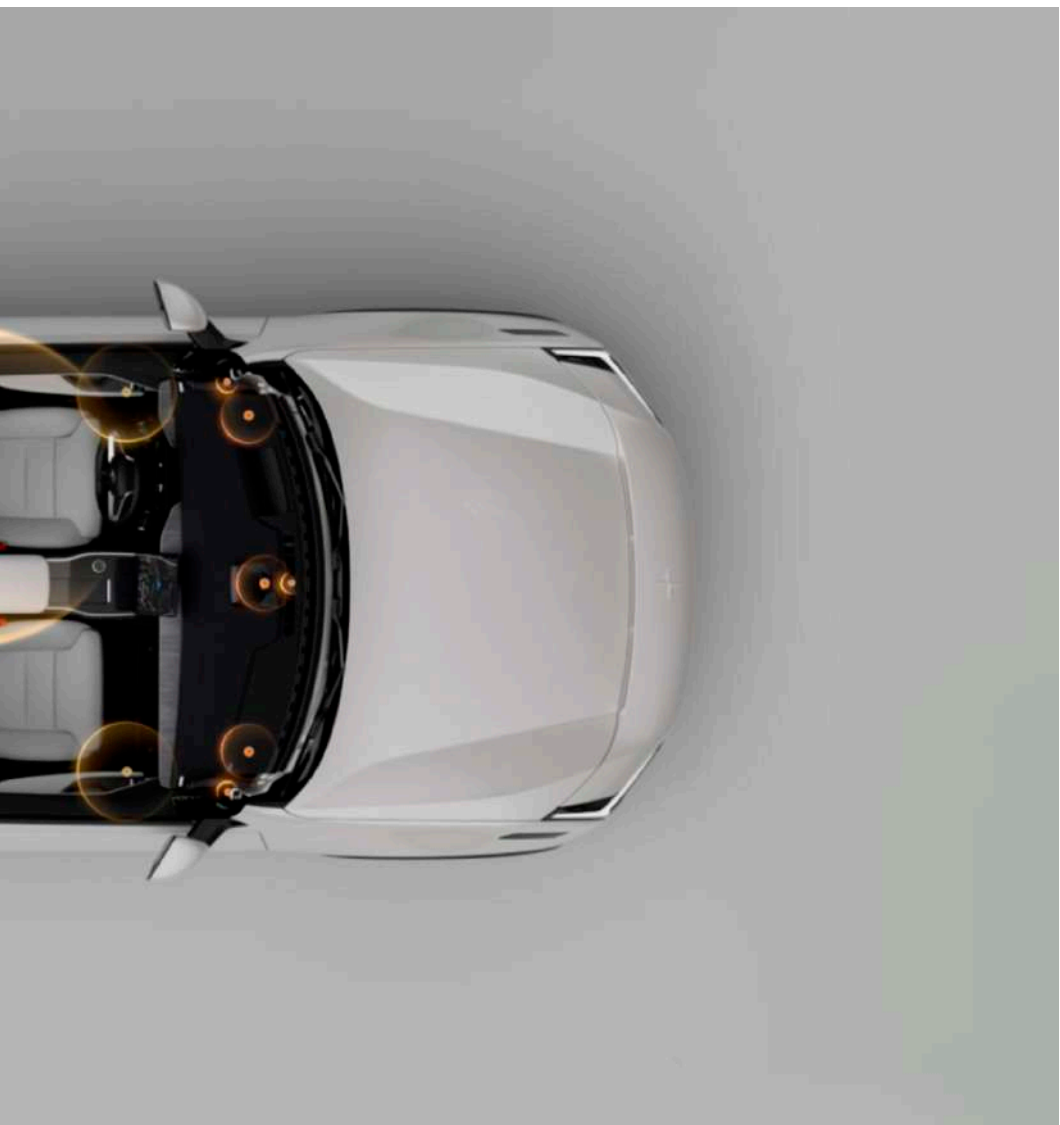



Roofline

By lowering the roofline, Polestar 3 has a distinctive silhouette ideally suited for electrification and without compromising on interior space.

Panoramic roof

Made of hi-tech, laminated glass, the panoramic roof reduces 95.5% of UV radiation, lowers cabin noise, and increases the feeling of space within.









Outer design

Design is the tool we use to integrate the latest intelligent technology into the exterior design of Polestar 3. This results in sculpted surfaces, discreet details, and optimised aerodynamics to give a sleeker, more technical look.



Headlights

The optional HD LED headlights use 1.3 megapixels to optimise the light pattern in all driving conditions. The pixels are also able to shade out oncoming vehicles reducing glare and improving safety.

Not available in North America.



Aerodynamics

The rear wing and aero blades work to optimise airflow across the body surface. This reduces drag and turbulence while optimising range.

Rear light bar

The rear light bar illuminates adaptively to the surrounding light conditions.





Snow



Space



Magnesium



Midnight



Thunder



Jupiter

22" Performance
Performance pack



22" Sport
Single option requires Pro Pack



21" Pro
Pro pack



21" Plus
Single option



20" Aero
Standard





Packs and options

An exclusive range of exterior colours and interior themes, along with packs and single options, are designed to make every Polestar 3 configuration feel personal.



Including

- Pilot assist
- Lane change assist
- Park Assist Pilot
- 360° Cameras with 3D view

Pilot pack

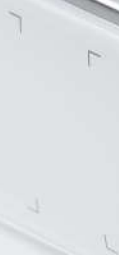

SmartZone
—
Sensor cluster

Including

- LiDAR from Luminar
- 3x additional cameras:
 - 1x Long range front-facing camera
 - 2x Side view cameras
- Camera and sensor cleaning on front and side cameras
- Additional NVIDIA Orin core computer with 254 TOPS
- Heated front wiper blades

Pilot pack with LiDAR
Requires Pilot pack



Including

- Graphical Head-up display
- Bowers & Wilkins for Polestar
- Soft close doors
- Power operated steering column
- Air Quality – PM2.5 sensor and filter
- Infrared coating windscreen
- Laminated acoustic lower rear windscreen
- Heated steering wheel
- Heated rear seats
- Heated front wiper blades
- Foldable load floor rear storage compartment

Plus pack
Requires Pilot pack



Including

- 21" Pro wheel
- Black seatbelt with Swedish gold stripe
- Laser-etched light line in Swedish gold
- Swedish gold valve caps

Pro pack

Not applicable with Performance pack



Including

- 22" Performance wheel
- Polestar Engineered chassis tuning
- Performance optimised tyres
- Brembo front brake callipers in Swedish gold
- Performance mode (Performance/Range)
- Laser-etched light line in Swedish gold
- Swedish gold seatbelts
- Swedish gold valve caps

Performance pack
Optional



Long range Single motor

Preliminary figures¹

Range up to WLTP¹

650 km

Torque

490 Nm

Power up to

220 kW

299 hp

0-100 km/h / 0-62mph

7.8 sec

Top speed

180 km/h

Long range Dual motor

Range up to WLTP¹

631 km

Torque

840 Nm

Power up to

360 kW
489 hp

0-100 km/h / 0-62mph

5.0 sec

Top speed

210 km/h

Range up to WLTP¹

561 km

Torque

910 Nm

Power up to

380 kW

517 hp

0-100 km/h / 0-62mph

4.7 sec

Top speed

210 km/h

Including

- Colour upgrade (Premium colour Snow)
- 1.3-Megapixel HD LED headlights (Requires Plus pack)
- 22" Sport (Requires Pro pack, not applicable with Performance pack)
- 21" Plus (Not applicable with Pro pack or Performance pack)
- Charcoal Bio-attributed MicroTech with repurposed Aluminium deco
- Charcoal Animal welfare wool with repurposed Aluminium deco
- Power foldable towbar (up to 2,200 kg) (3,500 lbs North America Tow hitch)
- Privacy glass rear windows
- AC Charging cable for public/home wallbox

Additional upgrades



Including

- Animal welfare Nappa leather seats in Jupiter/Zinc/Charcoal
- Massage in front seats
- Ventilation in front seats
- Power side support in front seats
- Black ash deco

Nappa upgrade
Requires Plus pack



Polestar 3

100% traced leather
8,1 kg CO₂e / m² material
Animal welfare secured







Safety

Polestar 3 shares safety technology with Volvo Cars. Structural innovations protect occupants, while advanced sensory technology prevents collisions, protecting pedestrians and cyclists. The driver is always informed of changing road conditions ahead. Information is shared in real-time with other connected Polestar cars.

Technical dimensions

Curb weight

2422- 2584 kg

Long range single motor

Long range dual motor

Wheelbase

2985 mm

Dimensions

L: 4900 mm

H: 1614 mm

W: 2120 mm

Luggage volumes front/rear

32 L / 597 L

Technical dimensions

Europe & ROW
Long range Dual motor

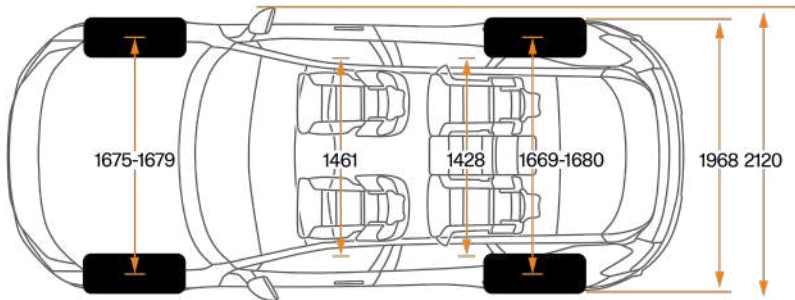
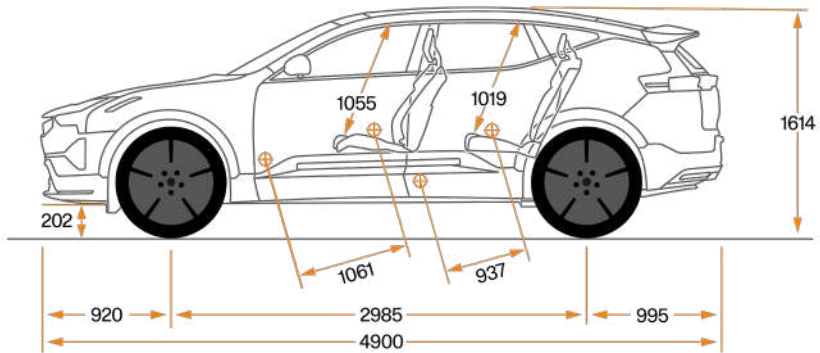

Dimensions (mm): L-4900 mm H-1614 mm W-2120 mm
Wheelbase (mm): 2985 mm
Tyre specs: 21" 265/45 295/40 - 22" 265/40 295/35
Luggage volumes front/rear (liters): 32 L / 597 L

North America
Long range Dual motor

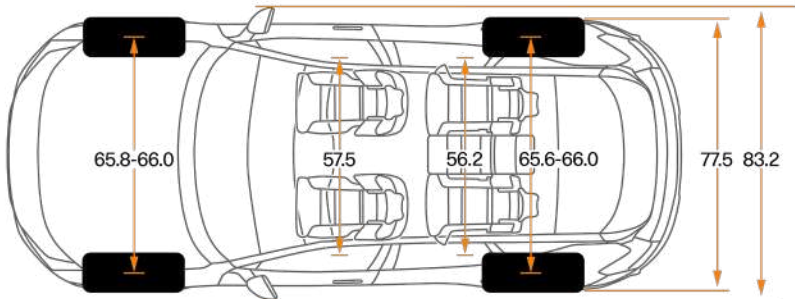
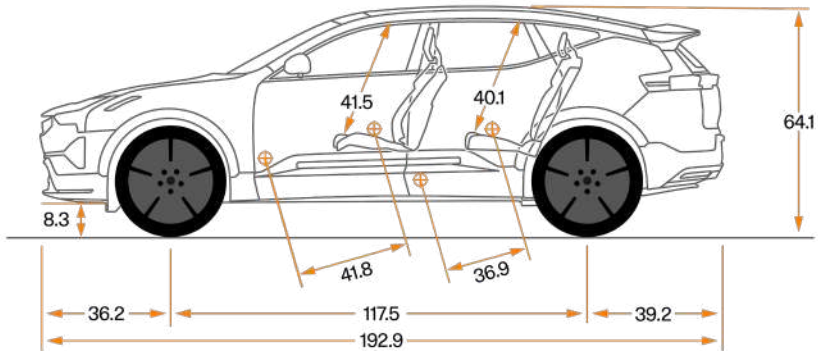

Dimensions (inches): L-192.9" H-64.1" W-83.2"
Wheelbase (inches): 117.5"
Tyre specs: 21" 265/45 295/40 - 22" 265/40 295/35
Luggage volumes front/rear (cubic feet): 1.1 cubic feet / 17.1 cubic feet

Reasons to add Polestar 3 to your fleet

01

Comfortable space

The Polestar 3 is a five-door and five-seat performance SUV with plenty of space for every passenger.

02

Equipped for a new era

With the Performance, Plus, Pro and Pilot pack, you have the opportunity to personalise the Polestar experience, enabling functionality and performance features.

03

Over-the-air updates

With regular remote software updates, the Polestar 3 stays up to date without the need to visit a service location.

04

Reach and range

Polestar 3 has an improved range estimate and is connected with Google built-in. Get where you're going and stay up to speed while on the way.

Polestar

—
Polestar Performance AB
Assar Gabrielssons väg 9
405 31 Göteborg, Sweden

Connect:

polestar.com
info@polestar.com
facebook.com/polestarcars
instagram.com/polestarcars
twitter.com/polestarcars
youtube.com/polestarcars
linkedin.com/company/polestarcars

Visiting address:

Polestar HQ
Assar Gabrielssons väg 9
418 78 Göteborg

Copyright

All rights reserved.
No part of this brochure may be
reproduced, distributed or transmitted in
any manner without the expressed written
consent of Polestar Performance AB.

© 2024 Polestar Performance AB

The Polestar trademarks are owned
by Polestar Holding AB. Other product
names, trademarks and company names
are property of their respective owners.

¹Preliminary figures. Subject to final certification.