

*CX-3*

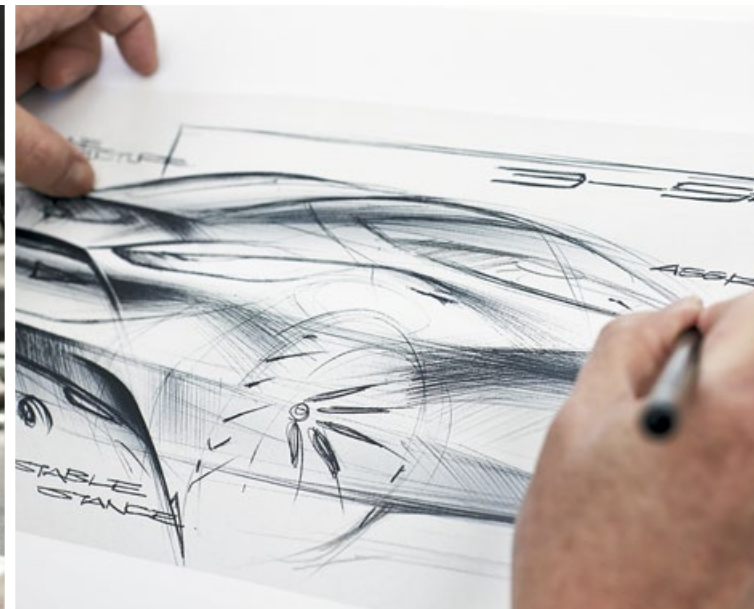

ZOOM-ZOOM

## IMAGINATION DRIVES US



Imagination is the world's most valuable resource. It's our window to the future, because if we can imagine it, we can create it. Mazda is built on a foundation of imagination and ingenuity. It's the fuel behind all we create and achieve. It has given us SKYACTIV TECHNOLOGY, 'KODO – Soul of Motion' design and countless successes that once existed only in someone's imagination. These pages show how imagination is an integral part of our innovative cars.



## CONTENTS

04	INTRODUCTION
06	EXTERIOR
08	INTERIOR
10	PERFORMANCE
12	SKYACTIV
14	CONNECTIVITY
16	FEATURED INNOVATION
18	CAPACITY
20	SAFETY
22	i-ACTIVSENSE
24	MODELS
32	SPECIFICATIONS
38	CONFIDENCE
39	COLOUR, TRIM & WHEELS



Akari in Soul Red Crystal Metallic.

## A MODERN CLASSIC

It's the small SUV with intuitive technology and Zoom-Zoom performance all encased in timeless design. Natural agility comes from SKYACTIV TECHNOLOGY, along with impressive fuel economy. MZD Connect brings your online world along for the ride, while i-ACTIVSENSE integrates intelligent safety. Experience responsive handling in your choice of front or all-wheel drive. From urban style to captivating performance, Mazda CX-3 is the small SUV that will be a modern classic.



## TIMELESS DESIGN

Mazda CX-3 is a timeless example of the 'KODO – Soul of Motion' design philosophy. Inspired by the instant energy bursts into motion, it's the powerful grace of an animal leaping into action. Balancing athletic presence, streamlined simplicity and luxurious detail, Mazda CX-3 brings rare imagination to the small SUV.

魂動

KODO : SOUL of MOTION



## STYLED TO IMPRESS

It's not just the dynamic exterior that's a modern classic. Mazda CX-3's cabin is crafted to feel elegant and equipped to impress. Instruments are carefully placed to maintain your focus on the drive. Clean lines envelop you, forming a fresh, modern space. The centre console design places a comfortable armrest in the perfect position for driver and front row passenger alike. Each model blends inviting trim and materials, using metallic highlights and detail to striking effect. Every model features MZD Connect as standard, where you control your contacts, music, social networks and more from a central touch screen<sup>§</sup>

<sup>§</sup> Please check the compatibility of your Bluetooth® device (particularly your mobile phone) with the specific Mazda vehicle you intend to purchase, as not all devices operate correctly. Visit [www.mazda.com.au/Bluetooth](http://www.mazda.com.au/Bluetooth) or consult your Mazda Dealer for further information.

<sup>#</sup> Leather interior includes some Maztex material on selected high-impact surfaces.



Akari in Soul Red Crystal Metallic.

## THE FREEDOM TO EXCITE

Agile and spirited, Mazda CX-3 drives like only a Mazda can. SKYACTIV TECHNOLOGY delivers performance with confident handling. The punchy 2.0L petrol unleashes responsive power and impressive fuel economy. Transmissions are sports-minded and refined in either automatic or manual. Mazda CX-3 offers front-wheel drive, or intelligent i-ACTIV AWD (all-wheel drive) that monitors and even predicts road conditions for maximum grip and performance. Enjoy a smooth ride as you carve through the city, or head for what's beyond.

## EFFICIENCY WITH DRIVING EXCITEMENT

Mazda is committed to reducing the environmental impact of our vehicles. Yet we'd never want to compromise the driving enjoyment that's core to our DNA. In answering this challenge, we arrived at a breakthrough - SKYACTIV TECHNOLOGY. In every way imaginable, Mazda CX-3 has been created to unlock efficiency and unleash performance potential. From a lightweight body to advanced engines, we've examined every possibility for improvement. Impressive petrol economy is boosted by i-stop. It cleverly saves fuel by turning off the engine when you come to a stop, perfectly poised for a quick restart. Enjoy the drive even more with G-Vectoring Control, which improves handling for a smoother ride.

\* Fuel consumption figures are based on ADR 81/02 test results. They are useful in comparing the fuel consumption of different vehicles. They may not be the fuel consumption achieved in practice. This will depend on traffic, road conditions and how the vehicle is driven.



### SKYACTIV-G 2.0L PETROL ENGINE

A new generation internal combustion engine generates more performance from less fuel. Precise multi-hole direct injection minimises fuel use. A unique piston design improves combustion to boost power and lower emissions. Reduced friction liberates extra power, while a 4-2-1 exhaust layout lifts efficiency. The 4-cylinder engine delivers a sporty 110kW of power and 195Nm of torque, using as little as 6.3 litres of fuel every 100km\* (combined).



### SKYACTIV-DRIVE AUTOMATIC TRANSMISSIONS & SKYACTIV-MT MANUAL TRANSMISSION

The 6-speed automatic transmission combines the best aspects of conventional automatic, continuously variable and dual clutch transmissions. It connects directly with the engine across a far wider range for increased fuel economy and more direct power delivery. The 6-speed SKYACTIV-MT manual transmission delivers accurate, sports-car style shifting through simplified design and a precision mechanism. More compact and lighter than previous Mazda transmissions, it significantly cuts friction to improve fuel economy.

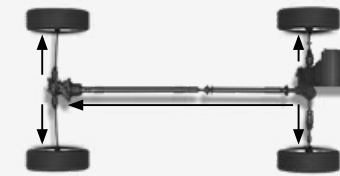

### i-ACTIV AWD INTELLIGENT ALL-WHEEL DRIVE SYSTEM

Mazda CX-3 offers an intelligent on-demand system that actively distributes torque under electronic control. i-ACTIV AWD sources information from 27 different sensors to predict changes in driving conditions, including road surface, weather, driver intentions and more. As a result, it offers maximum grip and vehicle control just when you need it.



### SKYACTIV-BODY

New-generation design and materials maximise lightness while achieving high rigidity. Key joints are strengthened by advanced techniques requiring no heavy reinforcement. High and ultra-high tensile steel cuts weight and boosts strength. Despite being light, Mazda CX-3 delivers world class collision protection.



### SKYACTIV-CHASSIS

The sense of 'oneness' between car and driver is heightened through careful optimisation throughout. Agility and high refinement are ensured by lightweight front strut and rear torsion beam suspension employing firm bushings and precise geometry. Electric power-assisted steering delivers secure yet responsive handling, and also saves fuel.



## STAY CONNECTED ON THE MOVE

Wherever you're headed, Mazda CX-3 is geared to go. Hook up a compatible smartphone and bring endless entertainment along for the ride<sup>§</sup> Standard on every grade, MZD Connect taps into your music and contacts, plus online content from Facebook to Twitter feeds and more. It even reads your texts and emails aloud. Everything is displayed on a centrally-located touch screen for maximum concentration on the road<sup>†</sup> Just as thoughtful is the multi-function commander dial, which allows control on the move with minimum distraction. Better still, you can drive menu choice, audio and navigation by voice.

# Leather interior includes some Maztex material on selected high-impact surfaces.

§ Please check the compatibility of your Bluetooth® device (particularly your mobile phone) with the specific Mazda vehicle you intend to purchase, as not all devices operate correctly. Visit [www.mazda.com.au/Bluetooth](http://www.mazda.com.au/Bluetooth) or consult your Mazda Dealer for further information.

† Driver-assistance features do not replace the driver's judgement and are not to be used in place of skilled and safe driving practices. It is the driver's sole responsibility to monitor vehicle surroundings and conditions and comply with all applicable laws at all times.

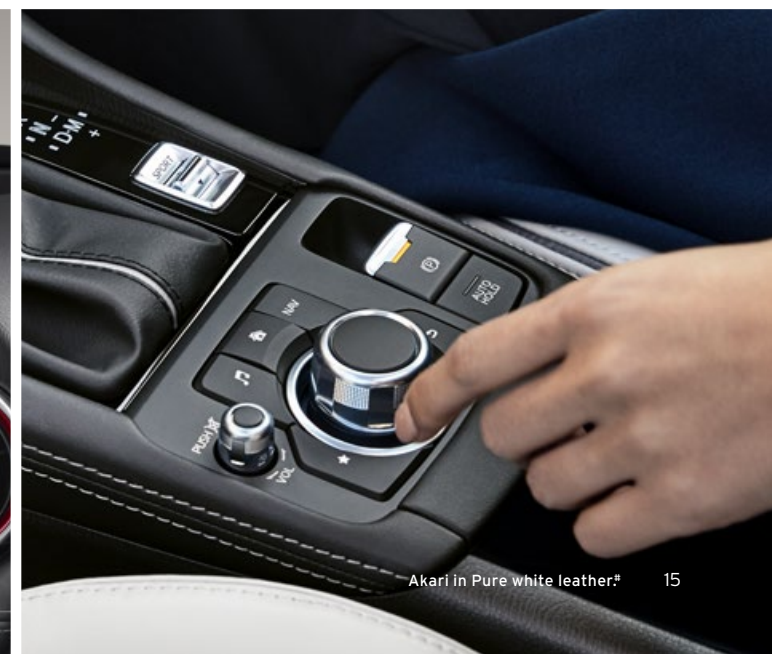

Akari in Pure white leather\*

15



## BE SURROUNDED BY CLEVER TECH

Mazda CX-3 keeps you plugged in and up to speed with cleverly integrated tech. Driving focus is sharpened by the full-colour Active Driving Display in sTouring and above. By putting key info such as current speed and navigation cues into your line of sight, your eyes remain on the road ahead! Every model includes hands-free Bluetooth® phone connectivity and music streaming, while USB ports keep devices playing and charging<sup>§</sup>

<sup>§</sup> Please check the compatibility of your Bluetooth® device (particularly your mobile phone) with the specific Mazda vehicle you intend to purchase, as not all devices operate correctly. Visit [www.mazda.com.au/Bluetooth](http://www.mazda.com.au/Bluetooth) or consult your Mazda Dealer for further information.

<sup>†</sup> Driver-assistance features do not replace the driver's judgement and are not to be used in place of skilled and safe driving practices. It is the driver's sole responsibility to monitor vehicle surroundings and conditions and comply with all applicable laws at all times.



### SPORTING SPIRIT

Drive selection switch lets you flick the powertrain into sport mode, allowing you to sprint through the gears with more immediacy. Automatic only.



### BRAKING MADE EASY

The Electric Parking Brake allows you to engage and disengage the park brake with the flick of a switch. While in traffic, Auto Hold keeps your vehicle stopped in place, even if you take your foot off the pedal!



## STYLE MADE VERSATILE

Comfortable, clever and capable, Mazda CX-3 features an intelligently-designed, well-crafted cabin that adapts to your lifestyle. The rear seats split 60/40 to allow for large or awkwardly shaped items. Folding down both rear seats creates a large, virtually flat-floored space. A handy two-way floor lets you customise carrying capacity even more - hide a handy extra compartment, or lower to expand the cargo bay. All your personal items have a place with plenty of useful storage.

## CONFIDENCE-INSPIRING SAFETY

With an interior promoting driver concentration plus sharp reflexes, Mazda CX-3 is well-armed to avoid potential trouble with a suite of state-of-the-art safety features. Collision protection is world-class, thanks to a highly rigid body integrating SRS airbags. The full suite of advanced safety technologies is on display including the addition of a new 360° View Monitor giving you a complete view of what's happening around you. Mazda CX-3 is designed with safety in mind so you can enjoy its exciting abilities with confidence!

† i-ACTIVSENSE and other safety technologies are driver assist technologies only and should not be used in place of skilled and safe driving practices. It is the driver's sole responsibility to monitor vehicle surroundings and conditions and comply with all applicable laws at all times.



Akari in Soul Red Crystal Metallic.

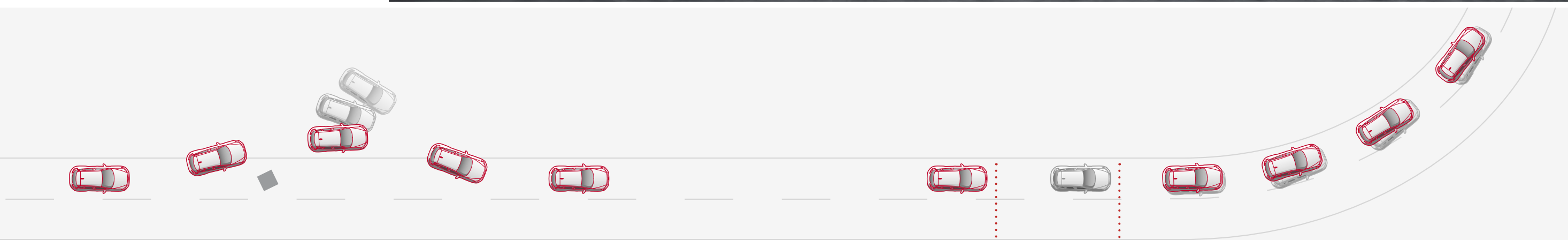

### BE PREPARED FOR WHAT'S AROUND THE CORNER

Unexpected hazards are a part of life. Thankfully Dynamic Stability Control (DSC) acts instantly, braking the inner rear wheel to offset understeer (or outer front wheel to combat oversteer). The Traction Control System (TCS) also reduces torque to the driven wheels to minimise skidding. The hazard can be steered around, as control is maintained.

### STOP WITH CONFIDENCE

Stopping distance with Emergency Brake Assist (EBA), Anti-lock Braking System (ABS) and Electronic Brake-force Distribution (EBD).

Stopping distance with no assistance.

### ENJOY THE RIDE

By finely controlling engine torque based on the steering and accelerator inputs of the driver, G-Vectoring Control (GVC) improves both handling for the driver and ride quality for the passengers around corners.

## i-ACTIVSENSE INTUITIVE PROTECTION

Mazda CX-3 protects you with impressive safety. With i-ACTIVSENSE advanced safety technologies, your sense of confidence grows even greater. These intelligent systems are designed to help you recognise potential hazards, avoid collisions and minimise the severity of accidents when they can't be avoided. Using radar, cameras and driver warnings, i-ACTIVSENSE is like having extra senses looking out for you†

† i-ACTIVSENSE and other safety technologies are driver assist technologies only and should not be used in place of skilled and safe driving practices. It is the driver's sole responsibility to monitor vehicle surroundings and conditions and comply with all applicable laws at all times.



**BLIND SPOT MONITORING (BSM)**  
By scanning external mirrors' blind spots, radars detect any unseen vehicles to alert the driver of hazardous lane changes. An LED icon on the relevant mirror is accompanied by beeping alerts. Standard on Maxx Sport and above.



**MAZDA RADAR CRUISE CONTROL (MRCC) WITH STOP & GO FUNCTION**  
MRCC automatically adjusts vehicle speed to maintain a safe distance from the car ahead. Automatic models come with a function that brings the car to a complete stop in traffic and takes off again once the traffic moves (if the stop is less than 3 seconds). If a complete stop exceeds three seconds, the car waits for the driver to initiate acceleration. Standard on Akari and Akari LE.

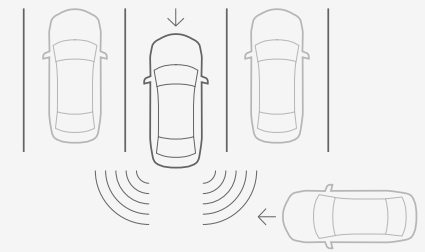

**REAR CROSS TRAFFIC ALERT (RCTA)**  
RCTA assists you when you're reversing from a parking space, warning of cars approaching from either side of your vehicle. The LED icon on both mirrors is accompanied by a beeping alert. Standard on Maxx Sport and above.

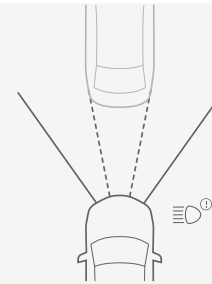

**ADAPTIVE LED HEADLAMPS (ALH)**  
Individual control of several LEDs allows precise adjustment of the lighting pattern. The system automatically broadens visibility at low speeds, shapes the high beam to help avoid dazzling other drivers and raises beam height at highway speeds to extend vision area. Standard on Akari and Akari LE.



**DRIVER ATTENTION ALERT (DAA)**  
When speeds above 65km/h are sustained for longer periods, the system monitors driver inputs and provides a visual warning if it detects signs of fatigue. DAA also provides an alert when 2 hours have elapsed. Standard on sTouring and above.

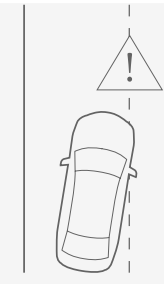

**LANE DEPARTURE WARNING (LDW)**  
LDW uses a windscreen-mounted camera to monitor road lane markings, sounding an audible warning if you're about to stray from your lane. Standard on Akari and Akari LE.



**TRAFFIC SIGN RECOGNITION (TSR)**  
The TSR system uses the forward-sensing camera to recognise Stop, No Entry and speed limit signs while driving. The detected speed limit is shown on the Active Driving Display. If the driver exceeds the speed limit, the traffic sign indication on the display flashes 3 times and a warning sound alerts the driver. The system provides constant safe driving support by preventing the driver from overlooking important traffic signage. Standard on sTouring and above.



**SMART CITY BRAKE SUPPORT - FORWARD (SCBS-F)**  
At forward speeds of 4-80km/h SCBS-F monitors the vehicle in front to assess the likelihood of a collision. If the system detects a high risk of impact, it issues visual and audible warnings and primes the brakes for a faster response. If the driver doesn't brake, SCBS-F brakes automatically. Standard across the range.

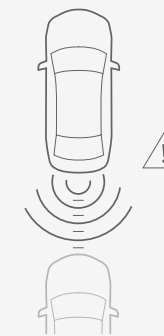

**SMART CITY BRAKE SUPPORT - REVERSE (SCBS-R)**  
SCBS-R monitors the vehicle behind you when reversing at speeds of 2-8km/h to assess the likelihood of a collision. If there is a high risk, the system will warn you and brake automatically if needed. Standard across the range.



Neo Sport in Snowflake White Pearl Mica.

## NEO SPORT FEATURES

- » 16-inch steel wheels with 215/60 tyres
- » Headlamps (Halogen)
- » Power mirrors (body coloured with folding function)
- » Front seats with: height adjustment and seat back pocket (passenger)
- » Rear seats with: 60/40 split fold backrest
- » Seat trim: Black cloth
- » Electric Parking Brake with Auto Hold
- » 7-inch full-colour touch screen display (MZD Connect)
- » Audio system with: AM/FM tuner, Digital radio (DAB+) and 6 speakers
- » Bluetooth® hands-free phone and audio capability<sup>§</sup>
- » Internet radio integration (Stitcher™ and Aha™)
- » Multi-function commander control
- » Advanced keyless push-button engine start
- » Parking sensors (rear)<sup>†</sup>
- » Reverse camera<sup>†</sup>
- » Smart City Brake Support [Forward/Reverse] (SCBS F/R)<sup>†</sup>

## POWERTRAIN

### SKYACTIV-G

- » 2.0 litre in-line 4 cylinder 16 valve DOHC S-VT petrol engine with i-stop
- » Drivetrain: FWD
- » Fuel consumption (combined): 6.6L/100km\* (FWD, man) or 6.3L/100km\* (FWD, auto)
- » Max power: 110kW @ 6,000rpm
- » Max torque: 195Nm @ 2,800rpm
- » Transmission: 6-speed manual (SKYACTIV-MT) or 6-speed auto (SKYACTIV-Drive)

\* Fuel consumption figures are based on ADR 81/02 test results. They are useful in comparing the fuel consumption of different vehicles. They may not be the fuel consumption achieved in practice. This will depend on traffic, road conditions and how the vehicle is driven.

† i-ACTIVSENSE and other safety technologies are driver assist technologies only and should not be used in place of skilled and safe driving practices. It is the driver's sole responsibility to monitor vehicle surroundings and conditions and comply with all applicable laws at all times.

§ Please check the compatibility of your Bluetooth® device (particularly your mobile phone) with the specific Mazda vehicle you intend to purchase, as not all devices operate correctly. Visit [mazda.com.au/Bluetooth](http://mazda.com.au/Bluetooth) or consult your Mazda Dealer for further information.



### ALWAYS IN CONTROL

Smart City Brake Support (SCBS) helps prevent or lessen low speed collisions by applying the brakes if you don't.



### PERFECT PARK

Rear parking sensors aid convenience and help prevent damage by sounding a warning when your car nears an obstacle.



### WELL CONNECTED

MZD Connect's infotainment links you to social networks, music and more. System info is displayed on a 7-inch colour screen.



### EYES BEHIND

The handy reverse camera means you'll always know what's behind you when you're in reverse.

**CX-3**  
MAXX SPORT



Maxx Sport in Eternal Blue Mica.

**MAXX SPORT FEATURES**

ADDITIONAL TO NEO SPORT

- » 16-inch alloy wheels
- » Headlamps auto on/off
- » Wipers (front) 2-speed with rain-sensing function
- » Seats (rear) with centre fold down armrest
- » Leather-wrapped gear shift knob and steering wheel
- » Overhead sunglasses storage box
- » Air-conditioning (climate control)
- » Satellite navigation
- » Blind Spot Monitoring (BSM)<sup>†</sup>
- » Rear Cross Traffic Alert (RCTA)<sup>†</sup>

**POWERTRAIN**

SKYACTIV-G

- » 2.0 litre in-line 4 cylinder 16 valve DOHC S-VT petrol engine with i-stop
- » Drivetrain: FWD or i-ACTIV AWD
- » Fuel consumption (combined): 6.6L/100km\* (FWD, man) or 6.3L/100km\* (FWD, auto) or 6.7L/100km\* (AWD, auto)
- » Max power: 110kW @ 6,000rpm
- » Max torque: 195Nm @ 2,800rpm
- » Transmission: 6-speed manual (SKYACTIV-MT) or 6-speed auto (SKYACTIV-Drive)

\* Fuel consumption figures are based on ADR 81/02 test results. They are useful in comparing the fuel consumption of different vehicles. They may not be the fuel consumption achieved in practice. This will depend on traffic, road conditions and how the vehicle is driven.

<sup>†</sup> i-ACTIVSENSE and other safety technologies are driver assist technologies only and should not be used in place of skilled and safe driving practices. It is the driver's sole responsibility to monitor vehicle surroundings and conditions and comply with all applicable laws at all times.



**STREET PRESENCE**

16-inch alloy wheels add to CX-3's sporty looks while also improving handling.



**FIND YOUR WAY**

Enjoy satellite navigation that's clear and easy to use with the 7-inch colour screen. Features spoken street names and advanced lane guidance.



**SAFELY SWITCH LANES**

Blind Spot Monitoring (BSM) scans the vehicle's blind spots for vehicles approaching from the rear, warning against hazardous lane changes with an LED icon and beeping alerts.



**SIDEWAYS GLANCE**

Rear Cross Traffic Alert (RCTA) keeps an eye out on both sides when reversing, alerting you to oncoming traffic you may not be able to see.



sTouring in Machine Grey Metallic.

## STOURING FEATURES

### ADDITIONAL TO MAXX SPORT

- » 18-inch alloy wheels with 215/50 tyres
- » Power mirrors (body coloured with heating and auto folding function)
- » Daytime running lamps (LED)
- » Front fog-lamps (LED)
- » Headlamps (LED)
- » Tail-lamps (LED)
- » Seat trim: Black Maztex/black cloth
- » Active Driving Display (flip-up)
- » Rear-view mirror with auto dimming function
- » Advanced keyless entry
- » Driver Attention Alert (DAA)<sup>†</sup>
- » Parking sensors (front)<sup>†</sup>
- » Traffic Sign Recognition (TSR)<sup>†</sup>

## POWERTRAIN

### SKYACTIV-G

- » 2.0 litre in-line 4 cylinder 16 valve DOHC S-VT petrol engine with i-stop
- » Drivetrain: FWD or i-ACTIV AWD
- » Fuel consumption (combined): 6.6L/100km\* (FWD, man) or 6.3L/100km\* (FWD, auto) or 6.7L/100km\* (AWD, auto)
- » Max power: 110kW @ 6,000rpm
- » Max torque: 195Nm @ 2,800rpm
- » Transmission: 6-speed manual (SKYACTIV-MT) or 6-speed auto (SKYACTIV-Drive)

\* Fuel consumption figures are based on ADR 81/02 test results. They are useful in comparing the fuel consumption of different vehicles. They may not be the fuel consumption achieved in practice. This will depend on traffic, road conditions and how the vehicle is driven.

<sup>†</sup> i-ACTIVSENSE and other safety technologies are driver assist technologies only and should not be used in place of skilled and safe driving practices. It is the driver's sole responsibility to monitor vehicle surroundings and conditions and comply with all applicable laws at all times.



### STUNNING STANCE

Eye-catching 18-inch alloy wheels add even more visual impact to an already dynamic shape.



### KNOW THE WAY

LED headlamps generate powerful, high quality light beams for superb visibility. Front parking sensors add to the sense of awareness.



### HIGHLY FOCUSED

Active Driving Display puts key information into your field of vision, allowing you to concentrate on the road ahead.



### NO KEY NEEDED

Smart keyless entry means as long as you're carrying the remote locking unit, you enter just by pressing a button on either front door.



Akari in Soul Red Crystal Metallic.

## AKARI FEATURES

### ADDITIONAL TO sTOURING

- » Power sliding and tilt glass sunroof
- » Front seats with: 2-position memory function (driver), 10-way power adjustment (driver) and heating function
- » Seat trim: Black leather or Pure white leather\*
- » Mazda Radar Cruise Control (MRCC)<sup>†</sup> with Stop & Go function<sup>^</sup>
- » 360° View Monitor<sup>†</sup>
- » Adaptive LED Headlamps (ALH)<sup>†</sup>
- » Lane Departure Warning (LDW)<sup>†</sup>

### AKARI LE<sup>1</sup> ADDITIONAL TO AKARI

- » Bright alloy wheels
- » Seat trim: Dark russet nappa leather<sup>#</sup>
- » Dark russet centre console, centre & door armrest with white stitch
- » Vent ring accent: Pure white metallic
- » Pure white door and dashboard trim inserts

## POWERTRAIN

### SKYACTIV-G (AKARI)

- » 2.0 litre in-line 4 cylinder 16 valve DOHC S-VT petrol engine with i-stop
- » Drivetrain: FWD or i-ACTIV AWD
- » Fuel consumption (combined): 6.6L/100km\* (FWD, man) or 6.3L/100km\* (FWD, auto) or 6.7L/100km (AWD, auto)
- » Max power: 110kW @ 6,000rpm
- » Max torque: 195Nm @ 2,800rpm
- » Transmission: 6-speed manual (SKYACTIV-MT) or 6-speed auto (SKYACTIV-Drive)

### SKYACTIV-G (AKARI LE)

- » 2.0 litre in-line 4 cylinder 16 valve DOHC S-VT petrol engine with i-stop
- » Drivetrain: FWD or i-ACTIV AWD
- » Fuel consumption (combined): 6.3L/100km\* (FWD, auto) or 6.7L/100km\* (AWD, auto)
- » Max power: 110kW @ 6,000rpm
- » Max torque: 195Nm @ 2,800rpm
- » Transmission: 6-speed auto (SKYACTIV-Drive)

<sup>^</sup> Stop & Go function on Automatic model only.

<sup>†</sup> i-ACTIVSENSE and other safety technologies are driver assist technologies only and should not be used in place of skilled and safe driving practices. It is the driver's sole responsibility to monitor vehicle surroundings and conditions and comply with all applicable laws at all times.

\* Fuel consumption figures are based on ADR 81/02 test results. They are useful in comparing the fuel consumption of different vehicles. They may not be the fuel consumption achieved in practice. This will depend on traffic, road conditions and how the vehicle is driven.

30 <sup>#</sup> Leather interior includes some Maztex material on selected high-impact surfaces.

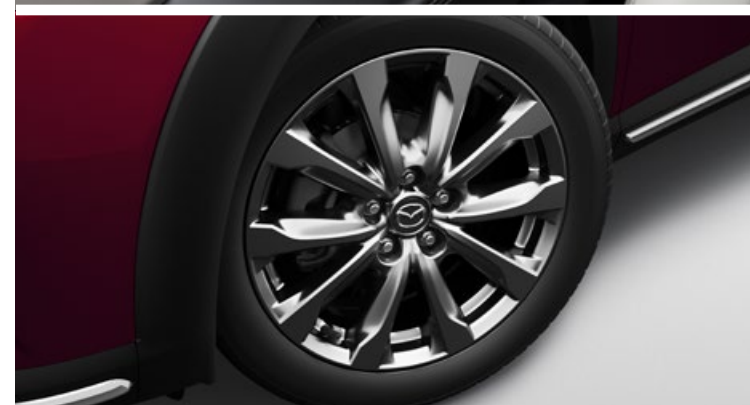

### CLASSIC WHEELS

Bright finished alloy wheels give your Mazda CX-3 a luxurious look that's both unique and eye-catching. Bright alloy wheels on Akari LE only.



### BEAUTIFULLY FINISHED

You'll discover premium materials and luxurious finishes at every turn thanks to a cleverly designed and carefully considered interior. Dark russet nappa leather on Akari LE only.



### STRESS-FREE CRUISING

Mazda Radar Cruise Control (MRCC) with Stop & Go function means you'll always keep a safe distance from the vehicle ahead.



### SEE WHAT'S AROUND

The 360° View Monitor stitches together images from four separate cameras to give you a complete picture and help minimise blind spots and avoid potential danger.

# SPECIFICATIONS

Powertrain	2.0L I4 Petrol FWD	2.0L I4 Petrol AWD
Bore and stroke (mm)	83.5 x 91.2	
Compression ratio	13.0 : 1	
Drivetrain	FWD	i-ACTIV AWD
Emissions standard	Euro stage V	
Engine capacity (cc)	1,998	
Engine type	2.0 litre in-line 4 cylinder 16 valve DOHC S-VT petrol (SKYACTIV-G) engine	
Fuel consumption (l/100km):		
Manual (combined)	6.6	-
Manual (extra urban)	5.6	-
Manual (urban)	8.3	-
Auto (combined)	6.3	6.7
Auto (extra urban)	5.5	5.9
Auto (urban)	7.7	8.0
Fuel system	Electronic direct injection	
Fuel tank capacity (litres)	48	44
Gear ratio - Manual/Auto:		
1st	3.363 / 3.552	- / 3.552
2nd	1.947 / 2.022	- / 2.022
3rd	1.300 / 1.452	- / 1.452
4th	1.029 / 1.000	- / 1.000
5th	0.837 / 0.708	- / 0.708
6th	0.680 / 0.599	- / 0.599
Reverse	3.385 / 3.893	- / 3.893
Final drive	4.105 / 4.325	- / 4.325
Maximum power (kW @ rpm)	110 @ 6,000	
Maximum torque (Nm @ rpm)	195 @ 2,800	
Recommended fuel	Unleaded (91RON or higher) or E10	
Throttle control	Electronic (drive-by-wire)	
Transmission:		
Manual	6-speed (Skyactiv-MT)	-
Auto	6-speed (Skyactiv-Drive)	

Model Availability	Neo Sport	Maxx Sport	sTouring	Akari	Akari LE
5-seat SUV:					
2.0L I4 Petrol FWD / 6-speed manual	●	●	●	●	-
2.0L I4 Petrol FWD / 6-speed automatic	●	●	●	●	●
2.0L I4 Petrol AWD / 6-speed automatic	-	●	●	●	●

Chassis and Powertrain Technologies	Neo Sport	Maxx Sport	sTouring	Akari	Akari LE
Automatic transmission drive selection	●	●	●	●	●
Automatic transmission kickdown switch	●	●	●	●	●
Electric Parking Brake with Auto Hold	●	●	●	●	●
Electric power assist steering	●	●	●	●	●
Hill Launch Assist (HLA)	●	●	●	●	●
i-Activ AWD	-	○	○	○	○
i-stop	●	●	●	●	●
Skyactiv-Body	●	●	●	●	●
Skyactiv-Chassis	●	●	●	●	●
Skyactiv-Vehicle Dynamics G-Vectoring Control (GVC)	●	●	●	●	●

Chassis	Neo Sport	Maxx Sport	sTouring	Akari	Akari LE
Brake diameter (mm):					
Front (FWD)	280	280	280	280	280
Front (AWD)	-	295	295	295	295
Rear	281	281	281	281	281
Brake type:					
Front	Ventilated disc				
Rear	Solid disc				
Suspension:					
Front	MacPherson strut				
Rear	Torsion beam				
Turning circle kerb to kerb (m)	10.6	10.6	10.6	10.6	10.6
Tyre size	215/60 R16	215/60 R16	215/50 R18	215/50 R18	215/50 R18
Tyre index	95V	95V	92V	92V	92V
Wheel size	16 X 6.5 J	16 X 6.5 J	18 X 7.0 J	18 X 7.0 J	18 X 7.0 J
Wheel type	Steel	Alloy	Alloy	Alloy	Alloy
Tyre size (spare)	T125/90 D16	T125/90 D16	T125/90 D16	T125/90 D16	T125/90 D16
Wheel size (spare)	16 x 4.0 T	16 x 4.0 T	16 x 4.0 T	16 x 4.0 T	16 x 4.0 T
Wheel type (spare)	Temporary (Steel)				

Weights and Capacities	Neo Sport	Maxx Sport	sTouring	Akari	Akari LE
Cargo room volume VDA (litres)					
Rear seats up and to tonneau cover	264	264	264	264	264
Rear seats folded down and up to roof	1,174	1,174	1,174	1,174	1,174
Kerb weight <sup>⊖</sup> (kg):					
2.0L I4 Petrol FWD / 6-speed manual	1,266	1,266	1,266	1,278	-
2.0L I4 Petrol FWD / 6-speed automatic	1,297	1,297	1,297	1,309	1,309
2.0L I4 Petrol AWD / 6-speed automatic	-	1,360	1,360	1,371	1,371
Towing capacity <sup>ⓧ</sup> (kg):					
Braked	1,200	1,200	1,200	1,200	1,200
Unbraked	640	640	640	640	640
Tow ball download maximum (kg)	50	50	50	50	50

● = Standard, ○ = Option, - = Not available.

\* Fuel consumption figures are based on ADR 81/02 test results. They are useful in comparing the fuel consumption of different vehicles. They may not be the fuel consumption achieved in practice. This will depend on traffic, road conditions and how the vehicle is driven.

⊖ Kerb weight is the unladen weight of the vehicle, including all fluids and a full tank of fuel.

ⓧ When fitted with a Mazda Genuine Towing kit. Subject to State and Territory regulations.

# SPECIFICATIONS

Dimensions		Neo Sport	Maxx Sport	sTouring	Akari	Akari LE
Ground clearance (mm):	Laden	155	155	155	155	155
	Unladen	160	160	160	160	160
Overall length (mm)		4,275	4,275	4,275	4,275	4,275
Overall width (mm)		1,765	1,765	1,765	1,765	1,765
Overall height (mm)		1,535	1,535	1,535	1,535	1,535
Track (mm):	Front	1,525	1,525	1,525	1,525	1,525
	Rear	1,520	1,520	1,520	1,520	1,520
Wheelbase (mm)		2,570	2,570	2,570	2,570	2,570

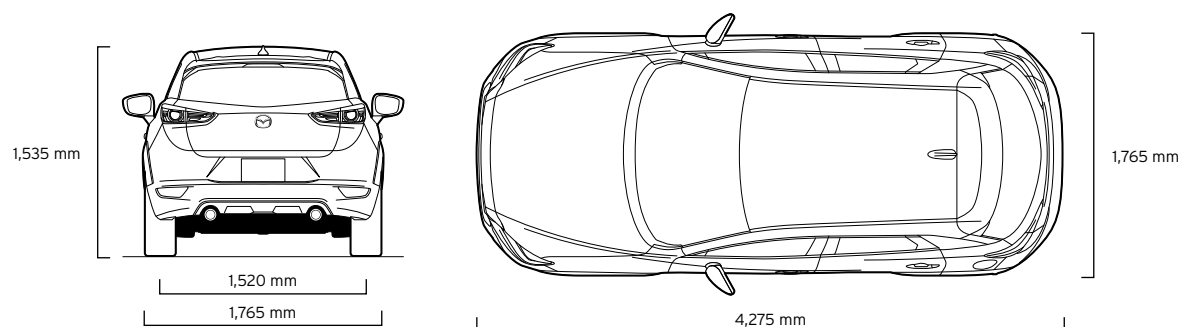
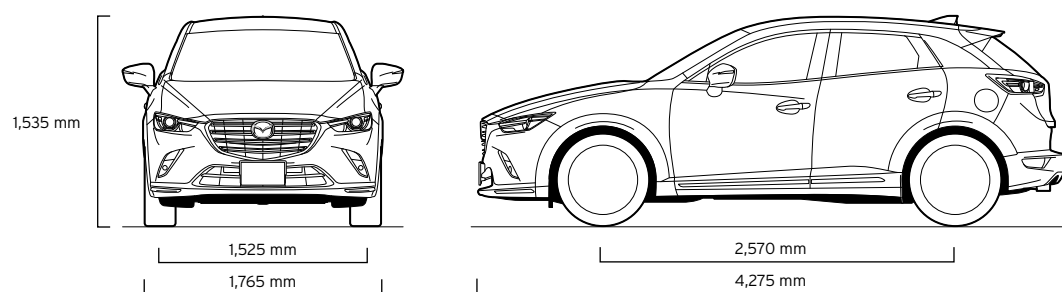

Exterior	Neo Sport	Maxx Sport	sTouring	Akari	Akari LE
Daytime running lamps (LED)	-	-	●	●	●
Door handles (body coloured)	●	●	●	●	●
Exhaust extensions (chrome)	●	●	●	●	●
Front and rear bumpers (body coloured)	●	●	●	●	●
Front fog-lamps (LED)	-	-	●	●	●
Green-tinted windscreen, side and rear windows	●	●	●	●	●
Headlamps (Halogen)	●	●	-	-	-
Headlamps (LED)	-	-	●	●	●
Headlamps auto on/off function	-	●	●	●	●
Power mirrors (body coloured)	●	●	●	●	●
Power mirrors (electric folding)	●	●	-	-	-
Power mirrors (auto folding)	-	-	●	●	●
Power mirrors (heated)	-	-	●	●	●
Power sliding and tilt glass sunroof	-	-	-	●	●
Power windows	●	●	●	●	●
Rear spoiler	●	●	●	●	●
Tail-lamps (LED)	-	-	●	●	●
Window demister (rear)	●	●	●	●	●
Wipers (front) 2-speed with rain-sensing function	-	●	●	●	●
Wipers (front) 2-speed with variable intermittent function	●	-	-	-	-
Wiper (rear) with intermittent function	●	●	●	●	●

Seats	Neo Sport	Maxx Sport	sTouring	Akari	Akari LE
Front seats with:	2-position memory function (driver)	-	-	●	●
	10-way power adjustment (driver)	-	-	●	●
	Adjustable head restraints	●	●	●	●
	Heated function	-	-	-	●
	Height adjustment	●	●	●	●
	Lumbar support adjustment (driver)	-	-	-	●
	Rake and slide adjustment	●	●	●	●
	Seat back pocket (passenger)	●	●	●	●
Rear seats with:	60/40 split fold backrest	●	●	●	●
	Adjustable head restraints	●	●	●	●
	Centre fold down armrest	-	●	●	●
Seat trim:	Black cloth	●	●	-	-
	Black Maztex/black cloth	-	-	●	-
	Black leather <sup>#</sup>	-	-	-	●
	Pure white leather <sup>#</sup>	-	-	-	○
	Dark russet nappa leather <sup>#</sup>	-	-	-	-

● = Standard, ○ = Option, - = Not available.

# SPECIFICATIONS

Interior	Neo Sport	Maxx Sport	sTouring	Akari	Akari LE
Active Driving Display	–	–	●	●	●
Air-conditioning	●	–	–	–	–
Air-conditioning (climate control)	–	●	●	●	●
Ambient temperature display	●	●	●	●	●
Critical function warning lights/chimes	●	●	●	●	●
Cruise control	●	●	●	●	●
Mazda Radar Cruise Control with Stop & Go function <sup>2</sup>	–	–	–	●	●
Cupholders	●	●	●	●	●
Door bottle holders (front and rear)	●	●	●	●	●
Glove box	●	●	●	●	●
Instrument panel light dimmer	●	●	●	●	●
Interior illumination:					
Cargo room lamp	●	●	●	●	●
Entry system with delayed fade	●	●	●	●	●
Map reading spot lamps	●	●	●	●	●
Power window switch (driver)	●	●	●	●	●
Interior release for fuel filler door	●	●	●	●	●
Leather-wrapped:					
Gear shift knob	–	●	●	●	●
Steering wheel	–	●	●	●	●
One touch (up and down) power window (driver)	●	●	●	●	●
Overhead sunglass storage box	–	●	●	●	●
Rear-view mirror with auto dimming function	–	–	●	●	●
Tachometer and electronic odometer/tripmeter	●	●	●	●	●
Tilt and telescopic adjustable steering wheel	●	●	●	●	●
Trip computer	●	●	●	●	●
Vanity mirrors (front)	●	●	●	●	●

Infotainment	Neo Sport	Maxx Sport	sTouring	Akari	Akari LE
7-inch full colour touch screen display (MZD Connect)	●	●	●	●	●
AM/FM tuner	●	●	●	●	●
Auxiliary-audio input jack (3.5mm mini-stereo)	●	●	●	●	●
Bluetooth® hands-free phone and audio capability <sup>§</sup>	●	●	●	●	●
Digital radio (DAB+)	●	●	●	●	●
Internet radio integration (Stitcher™ and Aha™)	●	●	●	●	●
Multi-function commander control	●	●	●	●	●
Radio Data System (RDS) program information	●	●	●	●	●
Satellite navigation	○	●	●	●	●
Speakers (6)	●	●	●	●	●
Steering wheel-mounted audio controls	●	●	●	●	●
USB-audio input port (iPod compatible)	●	●	●	●	●

<sup>2</sup> Stop & Go function on Automatic model only.

<sup>§</sup> Please check the compatibility of your Bluetooth® device (particularly your mobile phone) with the specific Mazda vehicle you intend to purchase, as not all devices operate correctly. Visit [www.mazda.com.au/Bluetooth](http://www.mazda.com.au/Bluetooth) or consult your Mazda Dealer for further information.

Safety and Security	Neo Sport	Maxx Sport	sTouring	Akari	Akari LE
360° View Monitor	–	–	–	●	●
Adaptive LED Headlamps (ALH)	–	–	–	●	●
Advanced keyless entry	–	–	●	●	●
Advanced keyless push-button engine start	●	●	●	●	●
Airbags SRS:					
Front (driver and passenger)	●	●	●	●	●
Side (front)	●	●	●	●	●
Curtain (front and rear)	●	●	●	●	●
Anti-lock Braking System (ABS)	●	●	●	●	●
Blind Spot Monitoring (BSM)	–	●	●	●	●
Childproof rear door locks	●	●	●	●	●
Driver Attention Alert (DAA)	–	–	●	●	●
Dynamic Stability Control (DSC)	●	●	●	●	●
Electronic Brake-force Distribution (EBD)	●	●	●	●	●
Emergency Brake Assist (EBA)	●	●	●	●	●
Emergency Stop Signal (ESS)	●	●	●	●	●
Engine immobiliser	●	●	●	●	●
High mount stop lamp	●	●	●	●	●
Hill Launch Assist (HLA)	●	●	●	●	●
Intrusion-minimising brake pedal	●	●	●	●	●
ISOFIX child restraint anchor points and top tethers	●	●	●	●	●
Lane Departure Warning (LDW)	–	–	–	●	●
Left-hand-side convex (wide angle) exterior mirror	●	●	●	●	●
Parking sensors (front)	–	–	●	●	●
Parking sensors (rear)	●	●	●	●	●
Rear Cross Traffic Alert (RCTA)	–	●	●	●	●
Remote central locking (2 transmitters)	●	●	●	●	●
Reverse camera	●	●	●	●	●
Seat-belt warning (front and rear)	●	●	●	●	●
Seat-belts 3-point lap-sash (all seats)	●	●	●	●	●
Seat-belts (front) with pretensioners, load-limiters and height adjustable shoulder anchorages	●	●	●	●	●
Side impact door beams	●	●	●	●	●
Smart City Brake Support [Forward/Reverse] (SCBS F/R)	●	●	●	●	●
Traction Control System (TCS)	●	●	●	●	●
Traffic Sign Recognition (TSR)	–	–	●	●	●
'Triple H' safety construction with front and rear crumple zones	●	●	●	●	●
Whiplash-minimising front seats	●	●	●	●	●

● = Standard, ○ = Option, – = Not available.

# ENJOY MAZDA CX-3 WITH CONFIDENCE

# MAZDA CX-3 COLOUR, TRIM & WHEELS



## BODY COLOURS

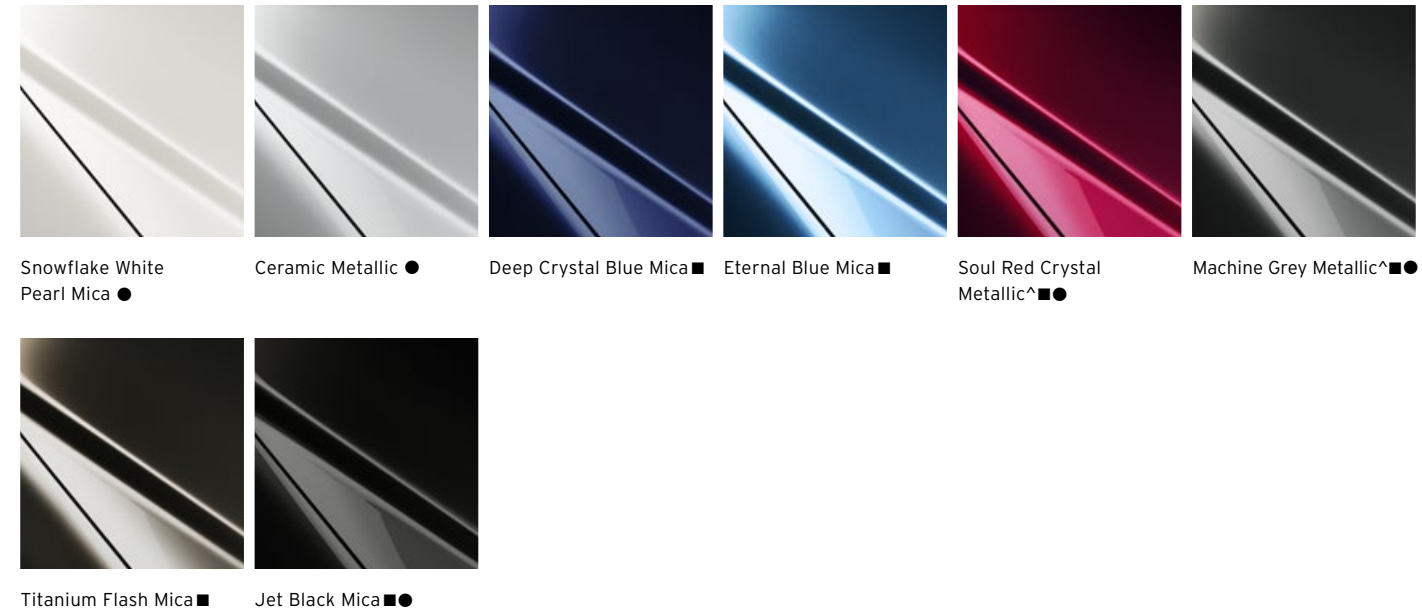

## INTERIOR TRIMS

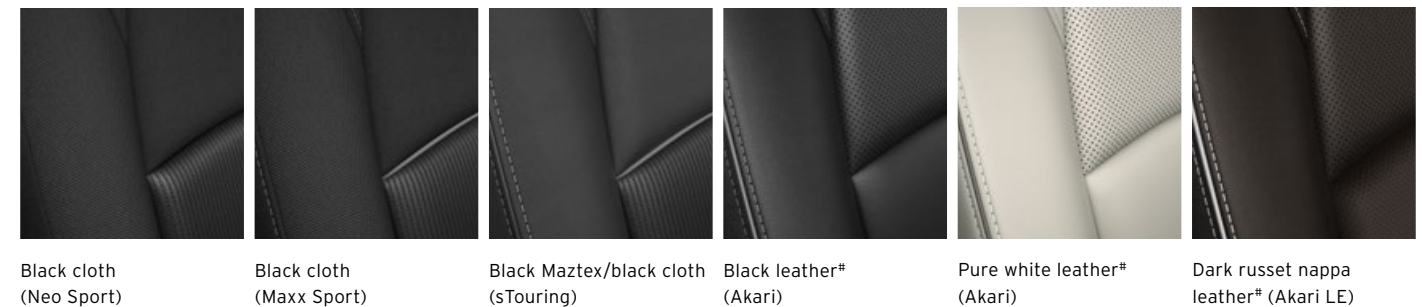

## WHEELS



^ At extra cost.

■ Pure white leather only available with Deep Crystal Blue Mica, Soul Red Crystal Metallic, Machine Grey Metallic, Titanium Flash Mica, Eternal Blue Mica and Jet Black Mica exterior colours.

● Dark russet nappa leather only available with Snowflake White Pearl Mica, Jet Black Mica, Machine Grey Metallic, Soul Red Crystal Metallic and Ceramic Metallic exterior colours.

# Leather interior includes some Maztex material on selected high impact surfaces.

All care is taken to ensure the accuracy of this brochure at the time of publication. Specifications, features and model availability may vary from State to State and may change without notice. Please refer to [mazda.com.au](http://mazda.com.au) or consult your Mazda Dealer prior to placing an order to ascertain current information on model availability, specifications, options, features and prices. Mazda Australia Pty Ltd will not be liable for any loss arising from the information in this brochure, whether in negligence or otherwise. Mazda Australia Pty Ltd ABN 78 004 690 804. 211A Wellington Road, Mulgrave, Victoria 3170. iPod is a trademark of Apple Inc., registered in the U.S. and other countries. Due to the nature of the printing process, colours may vary from those shown in this brochure. Ask your Dealer to show you a product sample.

**5** UNLIMITED  
YEAR KILOMETRE  
WARRANTY

### REST ASSURED - YOUR WARRANTY

The quality built into Mazda CX-3 is backed up by a 5 year, unlimited kilometre factory warranty and 6 year panel protection warranty.\*

**5** PREMIUM  
YEAR ROADSIDE  
ASSISTANCE

### HELP IS AT HAND - MAZDA ROADSIDE ASSISTANCE

Mazda Premium Roadside Assistance is now included with the purchase of all new Mazda vehicles. Whether it's a flat battery, locked-in keys, accident support and flat or damaged tyres, we've got you covered, day or night, city or country. With Premium Roadside Assistance, help is always there when you need it. (Terms and conditions apply.)

**MAZDA**  
FINANCE

### MAZDA FINANCE - FINANCE, YOUR WAY

Mazda Finance offers flexible finance options to suit you or your business. You can choose from a Mazda Finance Fixed Rate Car Loan or Mazda Assured\*, a loan option that enables you to enjoy a new Mazda more often. Each finance option comes with the reassurance of a Mazda Tailored Rate - an interest rate tailored to your individual circumstances.

**MAZDA**  
SERVICE SELECT

### MAINTAIN THAT ZOOM-ZOOM

Your Mazda CX-3 deserves the best in care. Servicing with Mazda Service Select gives your car the advantage of factory trained Service Technicians and advanced computer diagnostic systems. As well as maintaining your Mazda in A1 condition, you'll also be protecting your vehicle's outstanding resale value.

\*Terms, conditions, fees and charges apply. Mazda Assured Guaranteed Future Value products are available to approved customers of Mazda Finance, a division of Australian Alliance Automotive Finance Pty Limited ABN 63 002 407 703, Australian Credit Licence 513747. At participating dealerships only. #New 5 year unlimited kilometre warranty available on all brand new vehicles purchased from 1 August 2018. For full terms and conditions please visit <https://www.mazda.com.au/owners/warranty/>

IMAGINATION DRIVES US



Facebook.com/  
MazdaAus



YouTube.com/  
MazdaAustralia



Twitter.com/  
MazdaAus



Instagram.com/  
MazdaAus

Published January 2020. MAZ14376

For further information visit [mazda.com.au](http://mazda.com.au) or Freecall 1800 034 411