



Mazda MX-5



*ZOOM-ZOOM*



While the original Mazda MX-5 redefined the roadster, the new Mazda MX-5 breathes new spirit into an icon. Inspired by the philosophy of Jinba Ittai, 'rider and horse as one', Mazda engineers have created a sports car that effortlessly becomes one with its driver.

It's this unity that creates the perfect balance of elements for a thrilling driving experience – fun, excitement and adventure. It's a meeting of minds, a bond of trust, where everything works in harmony to deliver the ultimate adrenalin rush. Two distinct personalities merge to create the ultimate partnership. The new Mazda MX-5. Now that's Zoom Zoom.

# Jinba Ittai

The passion behind the new Mazda MX-5 drove us to achieve an affinity between car and driver never before imagined. This 'oneness' we call Jinba Ittai.



**6 Unity**

Superb handling and driving dynamics.

**8 Balance**

Responsive engines and optimised weight means outstanding performance.

**12 Harmony**

Beauty, functionality and craftsmanship.

**16 Trust**

Comprehensive safety systems.

**18 Personality**

Equipment grades, options and accessories.

**22 Partnership**

Mazda Services.







# unity

Feel connected. Feel alive. Feel the pounding of synchronised heartbeats.

Slide into the driver's seat, slip into gear, put your foot on the accelerator and the connection is instant. With its stiff chassis, precise steering and double wishbone suspension, the Mazda MX-5 delivers advanced driving dynamics and incredible handling.

Mastering every twist and turn with the ultimate precision, the Mazda MX-5 responds instantly to your every move. It's as if it can read your mind. In fact, you'll feel like your Mazda MX-5 is an extension of you.



### Weight distribution

An excellent power-to-weight ratio and 50:50 weight distribution further enhance Mazda MX-5's breathtaking drive.



### Engines

Choose the lively 1.8 MZR (93 kW / 126 PS) or the powerful 2.0 MZR (118 kW / 160 PS) – both delivering superb performance.



# balance

Responsive. Precise. Nimble. It's all about getting the balance right.

How do you combine solid stability with a chassis that is keen to alter speed or direction in a fraction of a second? The answer is Mazda MX-5's 'gram strategy'. By intelligently locating major components and carefully scrutinising weight-trimming opportunities, Mazda engineers have made every gram count. Using new, high-strength, low-weight types of steel, weight-saving structures, and where appropriate, replacing steel with lighter material, Mazda engineers have succeeded in dramatically lowering the Mazda MX-5's overall weight.

The result is an impressive power-to-weight ratio, made even more effective through a combination of front engine and rear wheel drive that gives a 50:50 weight distribution, and Mazda MX-5's commitment to deliver breathtaking driving, cornering and braking performance, elevating the Mazda MX-5 into a class of its own.

So, whether you favour the 1.8 MZR (93 kW / 126 PS) or 2.0 MZR (118 kW / 160 PS) with either 5- or 6-gear manual transmission, the result is a perfect blend of handling and performance.









# harmony

When every detail is designed around you, you know you've found a kindred spirit.



The Mazda MX-5 blurs the boundaries between beauty and functionality. From the perfectly contoured sports seats and ergonomic shift knob to the stylish alloy touches, every detail works in harmony to create an interior inspiration.

In the Mazda MX-5, the balance between intricate craftsmanship and simple style is beauty in itself.



The Mazda MX-5 exudes inner beauty. With carefully crafted fabrics, sporty red illuminated instrument dials, shiny alloy touches and piano black trim; you'll experience a feast for the senses, every journey.



Then there's the optional advanced keyless entry system, leather seats and leather steering wheel with integrated audio controls, for added luxury. Even the Bose audio system is a driving experience in itself with its seven speakers and its digital amplifier with four channels of equalisation – switching automatically between roof-up and open-top driving.



# trust

Safety and performance can go hand in hand.



**Airbag System**

Mazda MX-5 features dual front and side airbags for optimum protection in the event of a collision.



**ABS and DSC**

The Anti-lock Braking System (ABS) with Electronic Brake-force Distribution (EBD) adjusts the braking force to suit the handling, while Dynamic Stability Control (DSC) responds to swerving tendency and stabilises the vehicle within milliseconds.

Freedom is the feeling of the wind rushing through your hair. Safety is the feeling that you're protected, however big the adrenalin rush. Mazda MX-5 effortlessly combines thrilling performance with advanced safety features for the ultimate driving experience.

As well as Dynamic Stability Control (DSC) and a Traction Control System (TCS), the Mazda MX-5 also has Limited Slip Differential (LSD), ensuring optimum engine power reaches the road when you are accelerating out of a tight turn. Then there's Mazda's Advanced Impact Distribution and Absorption System that efficiently disperses impact energy in a collision. Further safety features complete the picture, including a reinforced windscreen bar, heated rear window and xenon headlights with automatic levelling and washers.



# personality

Turn your passion up a level.



How far you take your passion for the Mazda MX-5 is entirely up to you. There are three distinct equipment grades to choose from as well as selected high-value options and option packages such as the Touring Pack with leather-wrapped steering wheel, gear shift knob and handbrake lever, stainless steel scuff plates and a premium cloth soft-top, or the Convenience Pack with its advanced keyless entry system and burglar alarm.

You can also choose from a range of stunning exterior colour choices to suit your personality, plus there's a selection of seat and soft-top colours and trims to further enhance your chosen look.



1 2



3 4



- 1 17" alloy wheels.
- 2 CD changer with MP3.
- 3 Hands-free kit, voice control Bluetooth adapter kit.
- 4 Transparent wind stop.
- 5 Hardtop.
- 6 Brushed alloy and illuminated gear shift knob.
- 7 Chrome fashion bar cladding.
- 8 Map net.



5

Make your identity known.

You can choose from a hardtop, alloy wheels and audio devices to give your Mazda MX-5 that little something extra. Then there's luggage, ski and bike carriers all tailored for a perfect fit and an exclusive luggage pack tailored specially to the dimensions of the Mazda MX-5's loadspace to optimise your space. Ask your Mazda dealer for further information about available accessories and merchandising.



Both luggage packs are specially designed for Mazda MX-5's loadspace area and fit perfectly into the moulding of the loadspace floor.

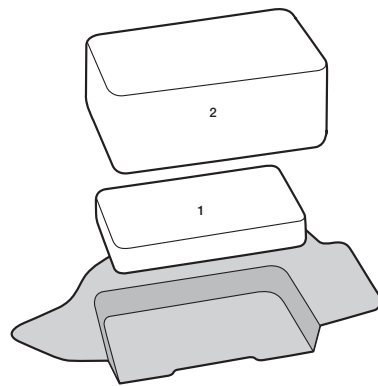

**Luggage Pack Option A**

- 1 Shoe bag.
- 2 Trolley.

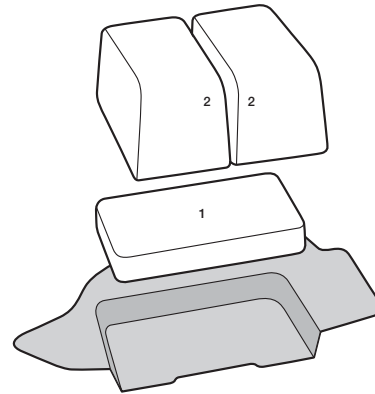

**Luggage Pack Option B**

- 1 Shoe bag.
- 2 Travel bag x 2.



6



7 8





# partnership

When the balance is right, you'll want to keep things that way.



Keeping you mobile is our greatest concern. In every respect.

There's only one thing more important than your Mazda: you. So, the perfection we insist upon in our vehicles also applies to our service. Our Mazda dealers offer you and your Mazda the very highest standards of service – any time, any place. So that your Mazda stays in tip-top condition and you stay perfectly happy.



Competent, unbureaucratic and direct. So that you can concentrate on one thing above all: driving your new Mazda.



## The Mazda Warranties.

### **3-year new car warranty up to 100,000 kilometres.**

The Mazda new car warranty applies for 3 years up to 100,000 kilometres, typical wearing parts are not covered by this warranty.

### **12-year warranty against corrosion breakthrough.**

The warranty against corrosion breakthrough lasts 12 years. Your Mazda authorised dealer / repairer will carry out a free visual inspection of the vehicle once a year.

### **3-year paintwork warranty.**

The Mazda paintwork warranty lasts 3 years, regardless of mileage. If any problems with the paintwork arise during this period, they will be rectified by a Mazda authorised dealer / repairer, provided the manufacturer is responsible for the defects.

## **Your Mazda dealer:**

### **Mazda Digital Service Record.**

Since 2005, Mazda has been introducing the Digital Service Record (DSR) with every new Mazda model. The Mazda Digital Service Record system provides increased security against counterfeit service documents and odometer tampering, and makes it easy to keep a Mazda's service history up to date. Stored on a central database, the DSR replaces the traditional paper service book and ensures a secure, accurate and permanent service history for the life of the vehicle. For further information, please ask your Mazda authorised repairer.

Mazda Motor Europe reserves the right to introduce changes in specification and equipment due to its ongoing product development. Colour and trim samples shown in this brochure may vary from the actual colours because of the limitations of the printing process. It is recommended that you consult your Mazda dealer when referring to these.

September 2005.

BJN 300796/EU/V2

**Internet: [www.mazda.com](http://www.mazda.com)**