

CANYON

2016



GMC WE ARE PROFESSIONAL GRADE



CANYON

Professional Grade. It's an attention to detail you can see in the fit and finish of components. You can feel it in the premium materials. And you can hear it in the quiet cabin. It's what makes Canyon your premium midsize pickup. Bringing all this together in one premium package makes Canyon everything you want in a smart-sized truck.

And, for 2016 we are proud to offer the efficiency and power of the all-new Duramax 2.8L Turbo Diesel engine.¹ See page 20 for more information.

¹Available fall 2015.



INTERIOR | 2

EXTERIOR | 10

PERFORMANCE | 20

SECURITY | 24

SELECTION | 26

SLT: BEST OF ALL, THIS IS A TRUCK.

Trucks are built to be rough and tough. But there's no rule that says they have to sound, feel and look that way on the inside. In Canyon SLT Crew and Extended Cabs, you'll find an exceptionally quiet and roomy interior; supportive, comfortably sculpted dual-firmness foam seats; premium materials such as aluminum trim, a soft-wrapped instrument panel and hand-stitched leather-wrapped steering wheel, as well as additional premium features.



LEATHER-APPOINTED
HEATED FRONT SEATS

REMOTE VEHICLE START

POWER DRIVER AND
PASSENGER SEATS WITH
POWER LUMBAR

AUTOMATIC CLIMATE
CONTROL





CANYON CREW CAB SLT INTERIOR IN JET BLACK
shown with available equipment.



CANYON EXTENDED CAB SLE INTERIOR IN JET BLACK
shown with available equipment.



8" DIAGONAL COLOR
TOUCH-SCREEN AUDIO
SYSTEM WITH
INTELLILINK¹

ALUMINUM TRIM

SOFT-TOUCH
INSTRUMENT PANEL
WITH CONTRASTING
STITCHING

TELESCOPIC STEERING
COLUMN

SLE: PLACES A PREMIUM ON MATERIALS.

At GMC, we believe in an inherent truth in materials. Not only must they look premium, they should feel good and provide durability. We made sure that Canyon SLE surrounds you with wear-resistant materials that are easy to maintain. You'll also find hidden storage areas plus well-appointed features throughout the truck.

¹Full functionality requires compatible Bluetooth[®] and smartphone. Some devices require USB connectivity.

YOUR FOUR-WHEEL MOBILE DEVICE.

Your always-connected world shouldn't stop because you're on the go. In the GMC Canyon, technologies such as available OnStar 4G LTE¹ with a built-in Wi-Fi[®] hotspot allow you to stay in touch on the road.



ONSTAR 4G LTE WI-FI¹ Available OnStar 4G LTE offers a built-in Wi-Fi hotspot (with 3-month/3GB trial, whichever comes first) for a speedy Internet connection for Web-enabled devices. It's reliably fast, easy to use and handles up to seven devices.

POWER SUPPLY Depending on the model and options you choose, you will have a convenient power supply: up to four USB ports² and two auxiliary 12-volt power outlets keep first- and second-row passengers connected and powered up.



INTEGRATED COMMUNICATION New for 2016 is available support for Apple CarPlay.^{TM3} It's the smarter way to use your iPhone[®] inside your Canyon. Now many of the functions you use your phone for—entertainment, communication and directions—appear on the built-in audio system display. Also, Canyon's available 8" diagonal LCD center touch-screen is the perfect display for the available Color Touch Sound System with IntelliLink.⁴ The system is also available with navigation.⁵ The screen provides instant information, dynamic response and predictive functionality. Both feature natural voice recognition.



REAR VISION CAMERA SYSTEM Standard on all models, its dynamic grid lines provide the perfect guide when backing up or hitching a trailer. Shown with the available 8" diagonal Color Touch Radio.

VOICE AND TOUCH-SCREEN NAVIGATION⁵ In response to your voice or touch, Canyon's available Navigation System displays 2-D or 3-D map graphics on the 8" diagonal center-mounted screen. NavTraffic⁶ [3 trial months of SiriusXM] incorporates real-time traffic and road conditions, directing you toward the most efficient route.



CENTER PANEL INSTRUMENTATION Access to controls and power sources is centrally located. This array of switches puts Canyon's important functions at your fingertips.

SAFETY ALERT TECHNOLOGIES Canyon offers an available Driver Alert Package, including Forward Collision Alert and Lane Departure Warning.

BOSE® PREMIUM SOUND The optional Bose Premium audio system is engineered to get you closer to the realism of a live performance with seven speakers to make sure you hear every note.



DRIVER INFORMATION CENTER To make information easy to view at a glance, GMC designers created an available 4.2" diagonal multicolor Driver Information Center (DIC). The DIC's menu can be navigated with steering-wheel controls.

AUTOMATIC CLIMATE CONTROL Canyon offers an available heating and air-conditioning system that allows you to simply set a desired temperature that is maintained automatically.

¹Devices must be WPA2-compliant with active OnStar service and data plan. Wi-Fi devices manufactured prior to 2006 may not be compatible. Please consult your device manufacturer for information regarding the WPA2 security protocol and Wi-Fi device compatibility. Vehicle must be started or in accessory mode to access Wi-Fi. Visit onstar.com for details and system limitations. ²Not compatible with all devices. ³Vehicle user interface is a product of Apple® and Apple's® terms and privacy statements apply. Requires compatible smartphone. Data plan rates apply. ⁴Full functionality requires compatible Bluetooth and smartphone. Some devices require USB connectivity. ⁵Map coverage available in the United States, U.S. Virgin Islands, Puerto Rico and Canada. ⁶If you subscribe after your trial period, *subscriptions are continuous until you call SiriusXM to cancel.* See SiriusXM Customer Agreement for complete terms at siriusxm.com. Other fees and taxes will apply. All fees and programming subject to change. For more information about NavTraffic, visit siriusxm.com/navtraffic. XM satellite service is available only to those in the 48 contiguous USA and D.C.

PRECISION ENGINEERING RUNS IN THE FAMILY.



SIERRA 3500 DENALI HD CREW CAB IN ONYX BLACK (left)
CANYON CREW CAB SLT IN BRONZE ALLOY METALLIC (center)
SIERRA 1500 ALL-TERRAIN CREW CAB SLT IN IRIDIUM METALLIC (right)
All vehicles shown with available equipment.





CANYON CREW CAB SLT IN EMERALD GREEN METALLIC
shown with available equipment.

SLT: THE PEAK.

To complement its well-appointed cabin, Canyon displays distinctive halogen projector-beam headlamps and signature GMC lighting as well as purposefully designed bodylines sculpted to help deliver efficiency and create a quiet interior. To personalize your Canyon to fit your life, a long list of accessories is available to help enhance its function and appearance. Choose Canyon SLT, and both Crew and Extended Cabs feature additional appointments.

18" POLISHED
ALUMINUM WHEELS

SLIDING REAR WINDOW

HEATED OUTSIDE
REARVIEW MIRRORS

PROFESSIONAL
GRADE ACCESSORIES;
SEE PAGE 28

BIKE RACK, ASSIST STEPS AND 18" CHROME WHEELS
are available dealer-installed accessories.



CANYON CREW CAB SLE IN COPPER RED METALLIC
shown with available equipment.



SLE: LOAD IT UP. WE DID.

Before you even load it up, Canyon SLE packs a lot. It contains a long list of standard features in one smart-sized premium package. Those design elements include a chrome grille surround and 17" aluminum wheels, as well as body-color door handles and mirror caps. It also provides functional equipment such as power mirrors and a driver-side spotter mirror. Like its cargo capacity, the list of Canyon SLE features is robust.

-
-

ICONIC GMC
CHROME GRILLE

FOG LAMPS

EZ-LIFT AND
LOWER TAILGATE

CHROME BELTLINE
MOLDINGS

ALL-TERRAIN: THE TRUCK FOR ALL SURFACES.

Living life to its fullest means not letting unpaved terrain stop you. That's why Canyon, with its available All-Terrain Package, gives you the ability to make your own path. Add a unique interior and you get a truck designed and engineered to meet your high standard of capability.

CANYON ALL-TERRAIN CREW CAB SLE IN CYBER GRAY METALLIC
shown with available equipment.

AUTOMATIC LOCKING
REAR DIFFERENTIAL

HILL DESCENT CONTROL

TRANSFER CASE SHIELD
ON 4WD MODELS

Z71 OFF-ROAD
SUSPENSION

CANYON ALL-TERRAIN EXTENDED CAB INTERIOR IN JET BLACK
shown with available equipment.



5" RECTANGULAR ASSIST STEPS
are available dealer-installed accessories.



EXCLUSIVE ALL-TERRAIN CABIN DESIGN You'll find carbon-fiber-inspired accents, unique All-Terrain seating with All-Terrain logo and contrasting red stitching, special dark aluminum IP material and other All-Terrain appointments.

Z71 OFF-ROAD SUSPENSION The legendary Z71 suspension allows you to go beyond mere sightseeing to truly explore the great outdoors.

AUTOMATIC LOCKING REAR DIFFERENTIAL It directs power to the wheel with the most traction on loose gravel or slippery surfaces.

TRANSFER CASE SHIELD Venturing off-pavement means encountering just about anything. The 4WD models have the added protection to help safeguard vital components under the truck.

ALL-TERRAIN WHEELS Dark Argent metallic cast-aluminum wheels with painted accents are shown.

BODY-COLOR ACCENTS Front and rear bumpers, as well as the grille surround, match the vehicle body color.

HILL DESCENT CONTROL This feature uses antilock braking for a smooth and controlled hill descent in rough terrain without you having to touch the brake pedal.

NIGHTFALL: PROFESSIONAL GRADE ATTITUDE.

The Canyon Nightfall Edition offers a striking combination of black and bright exterior styling elements. Available with the SLE Crew Cab, it tells the world something unique is coming their way.

MONOCHROMATIC
ONYX BLACK
APPEARANCE,
INCLUDING GRILLE

BODY-COLOR
FRONT BUMPER

CHROME CORNERSTEP
REAR BUMPER

BLACK 5" RECTANGULAR
ASSIST STEPS

18" MACHINED-
ALUMINUM WHEELS

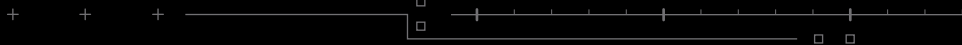



CANYON NIGHTFALL EDITION IN ONYX BLACK
shown with available equipment.

BODY-COLOR DESIGN Its monochromatic appearance is created with a body-color front bumper, grille, door handles and mirror caps.

BLACK ASSIST STEPS Stylish steps with textured step pads make it easier to get into and out of your Canyon. They're 5" rectangular, with a black powder-coat finish. The finish adds great style as well as excellent corrosion protection.

EXCLUSIVE MACHINED-ALUMINUM WHEELS These 18" bright machined wheels have Dark Argent painted inserts with matching caps and raised GMC logos.

RUGGED SPRAY-IN BEDLINER It provides a durable nonskid surface. The black liner covers the entire bed below the side rails, including the tailgate, front box top rail and lower tie-down loops.

POLISHED EXHAUST TIP This dual-walled, angle-cut exhaust tip complements the chrome CornerStep rear bumper.

REMOTE START A bold attitude doesn't mean having to give up the convenience of starting your Canyon from up to 197' away.

AUTOMATIC CLIMATE CONTROL This heating and air-conditioning system allows you to set your desired temperature and have it maintained automatically.

A LOT OF THINKING WENT IN HERE.

The thought was, “How can a cargo box do more than just carry your gear?” That’s how we arrived at innovations that help you get into the bed easily as well as organize and secure cargo. In addition, Canyon is engineered to deliver exceptional payload capability, thanks to its large cargo box.



EZ-LIFT AND LOWER TAILGATE Loading the cargo box takes less effort thanks to an available EZ-Lift and Lower Tailgate.

REMOVABLE AND LOCKING TAILGATE Allows the tailgate to be removed easily when you need a wide-open cargo box. It locks to secure cargo and help prevent tailgate theft.

ROLL-FORMED STEEL Unlike the stamped-steel approach, a roll-formed process is used in Canyon’s cargo bed, which allows for a higher-grade steel that’s stronger, lighter and more durable.



CORNERSTEP REAR BUMPER Integrated into the corners, the bumper steps make it easy to access the cargo box. The deep tread of the step accommodates large boots, and hand assists on the top of the side rails help give you a boost into the bed.

RAIL PROTECTORS Box rail protectors at the top of the box and across the top of the tailgate improve damage resistance.



SPRAY-IN BEDLINER To provide a permanent, nonskid surface, the available black liner covers the entire bed below the side rails, including the tailgate, front box top rail and lower tie-down loops.

TWO-TIER LOADING Standard two-tier loading allows a platform to split the load into upper and lower sections, making it easier to haul and store items.



MOVABLE TIE-DOWN HOOKS Four patented, load-bearing upper tie-down hooks are available. They can be repositioned in 13 locations around the box depending on the cargo being secured.



A NEW LEGEND IS BORN.

Like the legendary Duramax V-8, Canyon's available all-new Duramax 2.8L I-4 Turbo Diesel engine delivers abundant torque and horsepower—doing it all with stingy efficiency. In fact, no other midsize pickup competitor offers an available diesel engine. So when it comes to moving Canyon down the road or trail, all three of its engine options boast efficiency without sacrificing power, torque or a smooth ride. Learn more about Canyon's efficient technologies and specifications at gmc.com.

ENGINES

DURAMAX 2.8L I-4 TURBO DIESEL The Duramax 2.8L I-4 Turbo Diesel packs the power—with 181 horsepower at 3400 rpm and 369 lb-ft of torque at 2000 rpm—to tackle the toughest trails. The Duramax is B20 Biodiesel capable. It features a variable-geometry turbocharger for optimal power and efficiency across the rpm band and a balance shaft for greater smoothness. It also includes an exhaust brake that uses engine compression to slow the truck down. The engine is mated to a 6-speed automatic transmission.

3.6L V-6 VVT Engineered for responsiveness at all speeds, the 3.6L is the ideal blend of horsepower, torque and efficiency. With a direct-injected 24-valve, dual-overhead-cam design, it accelerates smoothly and quickly for confident highway passing and merging.

2.5L I-4 ENGINE Canyon benefits from the next generation of large-displacement four-cylinder engines engineered to generate surprising horsepower and torque to produce greater capability. The engine is also tuned to deliver more torque at a lower rpm for strong acceleration.

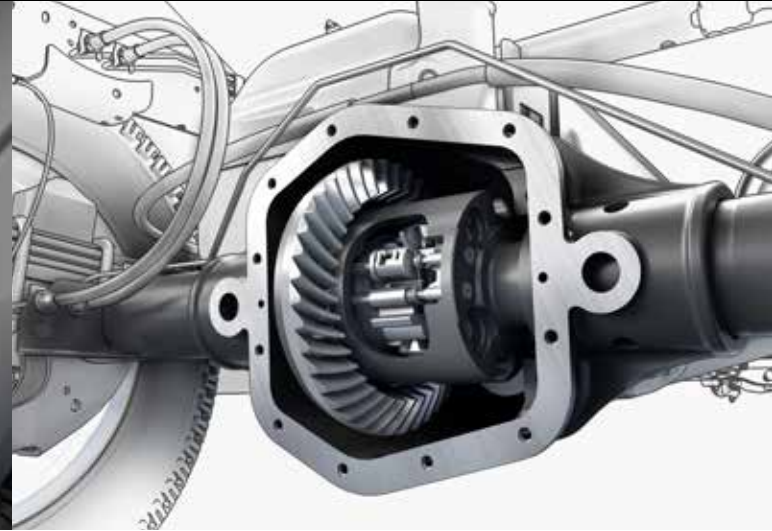

ACTIVE GRILLE SHUTTERS Included on SLE and SLT models with a gas engine, grille shutters automatically close to maximize aerodynamic efficiency when conditions are right. The shutters are designed to remain open in situations where max airflow is needed.

DIRECT INJECTION (DI) By injecting fuel directly into the combustion chamber at high pressure, fast and efficient combustion is achieved. DI enables higher torque and power and improved vehicle performance while improving efficiency.

VARIABLE VALVE TIMING (VVT) For responsiveness in low-speed city driving and bold power for open-road passing or trailering, Canyon gas engines feature continuously VVT. It monitors and adjusts valve open and close points for near-peak levels of torque across the entire range of engine speeds.

ELECTRONIC THROTTLE CONTROL Delivers outstanding response and allows tailoring of the throttle progression to the requirements of the vehicle and your driving needs. A sensor measures pedal position, signaling the throttle to open at the precise rate and angle.

CHASSIS

HYDRAULIC ENGINE MOUNTS These mounts reduce engine vibrations for a smoother, quieter ride.

CORROSION-RESISTANT DURALIFE BRAKE ROTORS Engineers invented a patented, GM-exclusive corrosion protection process designed to help double rotor life—which, of course, reduces maintenance costs—by hardening rotor surfaces. It protects against rust to help prevent steering-wheel shudder during braking.

AUTOMATIC LOCKING REAR DIFFERENTIAL Canyon offers this available feature that can lock both rear wheels so they can gain traction on loose gravel or slippery surfaces.

AUTOTRAC 4WD TRANSFER CASE This available 4WD system is ideal when traction conditions are variable. When driving in AUTO, the front axle is engaged and power is sent to the front and rear wheels automatically based on the driving situation.

ELECTRIC POWER STEERING This feature helps improve fuel efficiency versus engine-powered systems. The variable assist is tuned to provide less assist at highway speeds for a solid on-center feel, and more assist for less steering effort when you're maneuvering in tight spaces.

PUSHED FURTHER SO YOU CAN PULL MORE.

Canyon once again defies its size by being strong enough to trailer up to 7700 lbs¹ when equipped with the all-new Duramax 2.8L I-4 Turbo Diesel and up to 7000 lbs with the V-6 engine and the Trailering Package. The gas I-4 and V-6 models can trailer up to 3500 lbs¹ with the bumper-mounted ball hitch. Choose the Duramax engine, and an integrated Trailer Brake Controller and Diesel Exhaust Brake are included to make Canyon the first in its class to offer these important control features.

¹Canyon's 7700-lb rating requires 2WD Crew Cab model, available Trailering Package and Duramax 2.8L I-4 Turbo Diesel engine. Before you buy a vehicle or use it for trailering, carefully review the trailering section of the Owner's Manual. The weight of passengers, cargo and options or accessories may reduce the amount you can tow.

FULLY BOXED FRAME Canyon's frame is constructed with at least 70 percent high-strength steel for maximum people- and cargo-carrying capability.

AUTO GRADE BRAKING Included with the available automatic transmission, it senses when you want to slow your Canyon and engages a Grade Braking shift pattern to help maintain your desired speed.

TRAILERING PACKAGE On V-6 and Duramax Diesel models, achieve max trailering capacity with this available feature. Includes trailer hitch and 7-pin and 4-pin connectors.



CANYON CREW CAB SLT IN QUICKSILVER METALLIC
shown with available equipment.

HILL START ASSIST Sensors automatically detect when Canyon is on a 5 percent grade or more. The system holds the brakes momentarily or until the accelerator is pressed, preventing rollback.

TOW/HAUL MODE To give you even more power to accelerate when trailering or hauling heavy loads, Tow/Haul mode on V-6 and Duramax Diesel models raises automatic-transmission upshift points.

DIESEL EXHAUST BRAKE SYSTEM The available Diesel Exhaust Brake System works with Tow/Haul mode and Automatic Grade Braking to reduce the amount of braking needed while towing or traveling downhill.

TRAILER SWAY CONTROL This feature helps keep both you and your trailer heading in the same direction, automatically. It detects a swaying trailer and applies both Canyon's and the trailer's brakes (if properly equipped) to help bring it back in line.

TRAILER BRAKE CONTROLLER For control and easy monitoring of your trailer brakes, Canyon with the available Duramax engine features an integrated Trailer Brake Controller. It's located within easy reach of the steering wheel for quick adjustments.

HILL DESCENT CONTROL Activated by pushing a button within easy reach, it uses antilock braking for a smooth and controlled hill descent in rough terrain without you having to touch the brake pedal. (All-Terrain models only.)

TAPSHIFT For command over Canyon's shifting, TapShift puts controls on the shift lever. It's available only on automatic models.



AVOID TROUBLE DOWN THE ROAD, AND RIGHT IN FRONT OF YOU.

Canyon is the first in its class to offer collision-avoidance technologies often found in luxury vehicles—Forward Collision Alert and Lane Departure Warning. They are engineered to help enhance your awareness of the road and surrounding vehicles.

DRIVER AWARENESS Safety features are no substitute for the driver's responsibility to operate the vehicle in a safe manner. The driver should remain attentive to traffic, surroundings and road conditions at all times. Read the Canyon Owner's Manual for more important safety information.

FORWARD COLLISION ALERT The available Forward Collision Alert helps warn you when you're rapidly approaching another vehicle and it appears a collision is imminent.

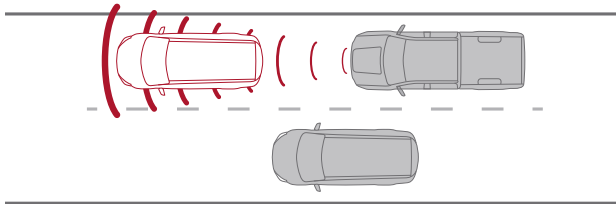

STABILITRAK Canyon's electronic stability control system helps improve stability by detecting and reducing traction loss.

CHILD SEAT ACCOMMODATION On Extended Cab models, the passenger-side rear-seat head restraint can be removed and inserted to extend the seat bottom to provide support for a variety of forward-facing child seats.

THEFT DETERRENCE To help ensure that it remains in your possession, Canyon offers theft-deterrence technologies to keep potential thieves at bay.

TIRE PRESSURE MONITORING SYSTEM¹ It uses sensors inside the wheels to alert you to the tires' status and inflation level through the Driver Information Center.

LANE DEPARTURE WARNING This available technology alerts you if you wander from your lane without signaling while traveling over 35 mph.

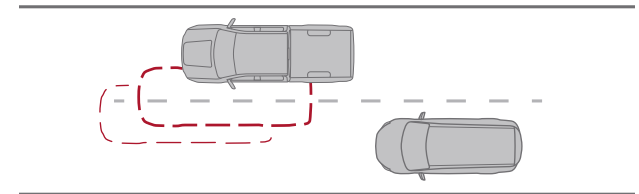

AIR BAGS² Six standard bags provide protection, including dual-stage frontal, head-curtain side with rollover protection, seat-mounted side-impact and a 360-degree sensor system to ensure proper bag deployment.

PROFESSIONAL GRADE PROTECTION.

Pro Grade Protection is standard on every Canyon. From maintenance to protecting your entire vehicle, you can drive with confidence.

2 INCLUDED MAINTENANCE VISITS WITHIN 2 YEARS/24,000 MILES³

3-YEAR/36,000-MILE BUMPER-TO-BUMPER LIMITED WARRANTY⁴

5-YEAR/60,000-MILE POWERTRAIN LIMITED WARRANTY⁴

CANYON

Professional Grade. It's an attention to detail you can see in the fit and finish of components. You can feel it in the premium materials. And you can hear it in the quiet cabin. It's what makes Canyon your premium midsize pickup. Bringing all this together in one premium package makes Canyon everything you want in a smart-sized truck.

And, for 2016 we are proud to offer the efficiency and power of the all-new Duramax 2.8L Turbo Diesel engine.¹ See page 20 for more information.

¹Available fall 2015.



CANYON

Professional Grade. It's an attention to detail you can see in the fit and finish of components. You can feel it in the premium materials. And you can hear it in the quiet cabin. It's what makes Canyon your premium midsize pickup. Bringing all this together in one premium package makes Canyon everything you want in a smart-sized truck.

And, for 2016 we are proud to offer the efficiency and power of the all-new Duramax 2.8L Turbo Diesel engine.¹ See page 20 for more information.

¹Available fall 2015.

CANYON

Professional Grade. It's an attention to detail you can see in the fit and finish of components. You can feel it in the premium materials. And you can hear it in the quiet cabin. It's what makes Canyon your premium midsize pickup. Bringing all this together in one premium package makes Canyon everything you want in a smart-sized truck.

And, for 2016 we are proud to offer the efficiency and power of the all-new Duramax 2.8L Turbo Diesel engine.¹ See page 20 for more information.

¹Available fall 2015.



CANYON

Professional Grade. It's an attention to detail you can see in the fit and finish of components. You can feel it in the premium materials. And you can hear it in the quiet cabin. It's what makes Canyon your premium midsize pickup. Bringing all this together in one premium package makes Canyon everything you want in a smart-sized truck.

And, for 2016 we are proud to offer the efficiency and power of the all-new Duramax 2.8L Turbo Diesel engine.¹ See page 20 for more information.

¹Available fall 2015.

CANYON

Professional Grade. It's an attention to detail you can see in the fit and finish of components. You can feel it in the premium materials. And you can hear it in the quiet cabin. It's what makes Canyon your premium midsize pickup. Bringing all this together in one premium package makes Canyon everything you want in a smart-sized truck.

And, for 2016 we are proud to offer the efficiency and power of the all-new Duramax 2.8L Turbo Diesel engine.¹ See page 20 for more information.

¹Available fall 2015.



CANYON

Professional Grade. It's an attention to detail you can see in the fit and finish of components. You can feel it in the premium materials. And you can hear it in the quiet cabin. It's what makes Canyon your premium midsize pickup. Bringing all this together in one premium package makes Canyon everything you want in a smart-sized truck.

And, for 2016 we are proud to offer the efficiency and power of the all-new Duramax 2.8L Turbo Diesel engine.¹ See page 20 for more information.

¹Available fall 2015.

CANYON

Professional Grade. It's an attention to detail you can see in the fit and finish of components. You can feel it in the premium materials. And you can hear it in the quiet cabin. It's what makes Canyon your premium midsize pickup. Bringing all this together in one premium package makes Canyon everything you want in a smart-sized truck.

And, for 2016 we are proud to offer the efficiency and power of the all-new Duramax 2.8L Turbo Diesel engine.¹ See page 20 for more information.

¹Available fall 2015.

CANYON

Professional Grade. It's an attention to detail you can see in the fit and finish of components. You can feel it in the premium materials. And you can hear it in the quiet cabin. It's what makes Canyon your premium midsize pickup. Bringing all this together in one premium package makes Canyon everything you want in a smart-sized truck.

And, for 2016 we are proud to offer the efficiency and power of the all-new Duramax 2.8L Turbo Diesel engine.¹ See page 20 for more information.

¹Available fall 2015.



IMPORTANT WORDS |

PRO GRADE PROTECTION

For 2016, Canyon comes with the Pro Grade Protection Plan, which includes two maintenance visits,¹ 3-year/36,000-mile bumper-to-bumper limited warranty² and 5-year/60,000-mile powertrain limited warranty,² Roadside Assistance and Courtesy Transportation.

Starting with the owner orientation—and full tank of gas—you receive when you take possession of your Canyon to the **24-Hour Roadside Assistance, Courtesy Transportation** and **Travel Benefits**, you receive a portfolio of owner privileges that lasts throughout your warranty. For expert product information, Roadside Assistance or other services, call 1-800-GMC-8782.

TRAVEL BENEFITS AND ROADSIDE ASSISTANCE Available around the clock: trip routing service, a program for reimbursement for trip interruption due to necessary warranty repairs, towing, flat tire change, jump-starts and more for 5 years or 60,000 miles (whichever comes first).

COURTESY TRANSPORTATION Available at participating dealers: shuttle service, reimbursement of certain public transportation or fuel expenses for overnight warranty repairs and courtesy rental for overnight work repairs. See your dealer for details.

GMC OWNER CENTER A complimentary, one-stop resource to enhance your GMC ownership experience. It's easy to sign up. Just go to gm.com/gmownercenter/gmc.

ONSTAR



OnStar services require vehicle electrical system (including battery), wireless service and GPS satellite signals to be available and operating for features to function properly. OnStar service required. OnStar acts as a link to existing emergency service providers. Not all vehicles may transmit all crash data. Visit onstar.com for coverage maps, details and system limitations. Services vary by model and conditions.

SIRIUSXM SATELLITE RADIO



SiriusXM Satellite Radio³ is standard on select Canyon models. It includes 3 trial months of service. SiriusXM Satellite Radio makes your drive come alive with commercial-free music channels from virtually every genre, artist-dedicated channels, live performances and more. Tune in to live play-by-play from the biggest sports, exclusive entertainment from top personalities, compelling talk, hilarious comedy, world-class news, local traffic and weather and family-friendly programming. Welcome to the world of satellite radio. Visit siriusxm.com for details.

GMC CERTIFIED SERVICE

GMC Certified Service To help your Canyon live up to its performance promise, GMC Certified Service—found exclusively at your GMC dealer—is there. With all the engineering excellence in Canyon, GM-trained technicians have the expertise to care for all of it.

ADDITIONAL NOTES

A NOTE ON CHILD SAFETY Always use safety belts and the correct child restraint for your child's age and size, even with air bags. Even in vehicles equipped with the Passenger Sensing System, children are safer when properly secured in a rear seat in the appropriate infant, child or booster seat. Never place a rear-facing infant restraint in the front seat of any vehicle equipped with an active frontal air bag. See your vehicle Owner's Manual and child safety seat instructions for more safety information.

TRAILERING AND OFF-ROAD INFORMATION Please carefully review the Owner's Manual for important safety information about trailering or off-road driving in your vehicle.

FLEET ORDERS Some standard content may be deleted with fleet orders. See dealer for details.

ENGINES GMC products are equipped with engines produced by GM Powertrain or other suppliers to GM worldwide. The engines in GMC products may also be used in other GM makes and models.

GMC.COM See more of Canyon on our website: gmc.com/canyon. More photos and information; hot links to related subjects; convenient dealer locator; pricing guide, spec out your own vehicle. Or call 1-800-GMC-8782.

BUYPOWER CARD™ Now it's even easier to get into the GMC of your dreams. Every purchase gives you Earnings redeemable toward part or even all of a new GMC, Chevrolet, Buick or Cadillac. Every year, enjoy 5 percent Earnings on your first \$5,000 in purchases and 2 percent unlimited Earnings after that. No expiration on Earnings and no limit on how much you can earn or redeem.



Learn more at buypowercard.com/catalog. YOUR CARD IS THE KEY.™

IMPORTANT WORDS ABOUT THIS CATALOG We have tried to make this catalog comprehensive and factual. We reserve the right, however, to make changes at any time, without notice, in prices, colors, materials, equipment, specifications, models and availability. Specifications, dimensions, measurements, ratings and other numbers in this catalog and other printed materials provided at the dealership or affixed to vehicles are approximates based upon design and engineering drawings and prototypes and laboratory tests. Your vehicle may differ due to variations in manufacture and equipment. Since some information may have been updated since the time of printing, please check with your GMC dealer for complete details. GMC reserves the right to lengthen or shorten the model year for any product for any reason, or to start and end model years at different times. All competitive claims are based on the latest information available at the time of printing and GM Midsize Truck segment.

AN IMPORTANT NOTE ABOUT ALTERATIONS AND WARRANTIES Installations or alterations to the original equipment vehicle (or chassis) as distributed by General Motors are not covered by the General Motors New-Vehicle Limited Warranty. The special body company, assembler, equipment installer or upfitter is solely responsible for warranties on the body or equipment and any alterations (or any effect of the alterations) to any of the parts, components, systems or assemblies installed by GM. General Motors is not responsible for the safety or quality of design features, materials or workmanship of any alterations by such suppliers.

NEW-VEHICLE LIMITED WARRANTY All GMC light-duty vehicles come with a fully transferable, no-deductible 5-year/60,000-mile (whichever comes first) Powertrain Limited Warranty. GM vehicles registered in the USA are also covered for 3 years or 36,000 miles (whichever comes first). Coverage includes tires and towing to your nearest GMC dealership. Repairs will be made to correct any vehicle defect and most warranty repairs will be made at no charge. In addition, rust-through corrosion will be covered for 6 years or 100,000 miles (whichever comes first). Canyon also comes with two maintenance visits within the first 2 years/24,000 miles (whichever comes first).¹ See dealer for details.

ASSEMBLY GMC vehicles and their components are assembled or produced by different operating units of General Motors, its subsidiaries or suppliers to GM worldwide. We sometimes find it necessary to produce GMC vehicles with different or differently sourced components than originally scheduled. Since some options may be unavailable when your vehicle is assembled, we suggest that you verify that your vehicle includes the equipment you ordered or, if there are changes, that they are acceptable to you.

GMMOBILITY.COM (1-800-323-9935) GM Mobility offers financial assistance for eligible adaptive equipment to make automotive travel easier for persons with disabilities or special transportation needs. To learn more about special GM Mobility offers, visit gmmobility.com.

¹Maintenance visits must occur within 2 years or 24,000 miles of vehicle delivery, whichever comes first. Does not include air filters. See participating dealer for other restrictions and complete details. ²Whichever comes first. See dealer for limited warranty details. ³If you subscribe after your trial period, *subscriptions are continuous until you call SiriusXM to cancel*. See SiriusXM Customer Agreement for complete terms at siriusxm.com. Other fees and taxes will apply. All fees and programming subject to change. For more information about NavTraffic, visit siriusxm.com/navtraffic. XM satellite service is available only to those in the 48 contiguous USA and D.C.

©2015 General Motors. All rights reserved. GM, the GM logo, GMC, the slogans, emblems, vehicle model names, vehicle body designs and other marks appearing in this catalog are the trademarks and/or service marks of General Motors, its subsidiaries, affiliates or licensors. Apple, Apple CarPlay, Siri and iPhone are registered trademarks of Apple, Inc. Facebook is a registered trademark of Facebook, Inc. Twitter is a registered trademark of Twitter, Inc. YouTube is a registered trademark of Google, Inc. Sirius, XM and all related marks and logos are trademarks of SiriusXM Radio, Inc. BlackBerry is a registered trademark of BlackBerry Limited.



FACEBOOK.COM/GMC



TWITTER.COM/THISISGMC



YOUTUBE.COM/GMC

VISIT US AT GMC.COM

