

---

2010  
**CTS**



*Cadillac*

---

2010  
**CTS**



## THE HITS JUST KEEP ON COMING.

For those who are passionate about fine cars, the letters “CTS” have come to signify something very special indeed. The excitement really started building in 2008 with the introduction of the second-generation Cadillac CTS Sedan, which the editors of *Car and Driver* Magazine immediately named to their prestigious 10Best list. For 2009, the big news was the launch of the remarkably refined ultra-high-performance CTS-V – nothing less than the most powerful, quickest-accelerating and outright fastest\* production V8-engine sedan in the world. *Car and Driver* took notice again and for 2009 both CTS and CTS-V were honoured with a place on their list of 10Best cars. Now in 2010, the new CTS Sport Wagon delivers a blend of style, performance, luxury and versatility that will forever change the way you think about what a wagon can be. Also new this year: a highly sophisticated 270-horsepower 3.0-litre double overhead cam V6 engine that employs technological innovations like Direct Injection and Variable Valve Timing (VVT) to reduce emissions and improve fuel efficiency. CTS for 2010. No matter which model you choose, when you turn it on, you can count on it to return the favour.

\*Equipped with manual transmission and regular production street tires.

*Cadillac*

*Cadillac*

## PURE, UNALLOYED EXCELLENCE.

The culmination of a century of Cadillac design innovation, CTS Sedan is as bold and beautiful as sculpted metal gets. It hunkers down on a long 2880 mm wheelbase and wide front and rear tracks, with sculpted fenders arching close to its substantial Michelin® blackwall tires. At the front, the bold grille is flanked by Cadillac's trademark vertical headlights, highlighted here with high-tech light pipes for an even more distinctive look. At the rear the vertical theme is echoed in the advanced LED tail lights, while bright dual exhaust tips speak of performance. It's an exciting experience – and you haven't yet turned the key.

### AIR EXTRACTORS

CTS's fender-mounted air extractors are more than a dramatic styling touch. They're a fully functional element in the car's underhood cooling system.

*Cadillac*

## AVANT-GARDE STYLE MEETS REAL-WORLD CAPABILITY.

The all-new CTS Sport Wagon is an exciting new take on a great automotive idea. Visually it's sleek, potent and elegant, with its extended roofline, dynamic, sloping rear roof pillars and roof-to-bumper LED tail lights. On the road it's every bit as precise and rewarding to drive as its Sedan stablemate, thanks to its advanced body structure, abundant V6 power and track-tuned suspension. And with a spacious, intelligently designed cargo area behind the rear seats, CTS Sport Wagon offers a kind of versatility that rivals many SUVs. If you're a discerning driver who lives life to the fullest, you may have just met your match.

*Cadillac*

## FOR THE GOOD LIFE, IT'S THE PERFECT FIT.

With CTS Sport Wagon, finding room for the dog, luggage, sports gear, shopping and other items is as easy as opening the standard power liftgate, which can be programmed to rise to your preferred height setting. Inside, you'll find a full 720 litres of cargo space behind the rear seats – nearly twice the capacity of CTS Sedan. On those occasions when you need to transport oversize loads, the rear seatbacks fold out of the way to create even more room. Additional cargo can be carried on the roof, thanks to a class-exclusive\* roof load management system with hidden roof rails and available cross bows. There's even a conveniently integrated four-wire connector at the rear to facilitate hooking up a trailer.

\*Based on 2009 Model Year competitive data for the GM Entry Luxury segment and latest competitive information available at time of printing.

### CARGO CONVENIENCE

CTS Sport Wagon's versatile cargo area features handy under-floor storage and adjustable rail-mounted tie-downs that make it easy to secure cargo.

*Cadillac*



## DRIVER-FOCUSED DESIGN.

While the CTS cabin provides a high level of comfort and entertainment for every occupant, its real focus is on you, the driver. For your convenience, the available Keyless Access System unlocks the doors automatically as you approach the vehicle. Inside, the atmosphere is welcoming and design and technology are both single-mindedly focused on the art of driving. The analogue gauges and electronic Driver Information Centre are more than stylish; they've been positioned with care and designed to deliver the vital vehicle and driving information you need at just a glance. Every switch and control provides satisfyingly positive feedback to your touch. You will find it's an environment that inspires confidence and enhances your control and enjoyment in every driving situation.

*Cadillac*

WE SETTLED FOR THE BEST.

GENUINE WOOD

In CTS, the steering wheel, transmission shifter, instrument panel, centre console and doors can be trimmed with the warmth of available genuine Sapele Pommele wood.



In the CTS cabin, Cadillac's talent for blending tradition and innovation is on full display. Among the traditional elements are supple leather seating surfaces and door, console and instrument panel trim that are cut, wrapped and sewn by master craftsmen. Then there are the interior's many standard leading-edge amenities, including heated, eight-way power adjustable front bucket seats designed with "thin-seat" technology that maximizes both comfort and interior space. For an even higher level of comfort, heated and ventilated bucket seats are also available.



ULTRAVIEW ROOF

Roughly twice the size of conventional sunroofs, CTS's available UltraView roof gives you a window on the sky above and helps brighten the cabin in all conditions.

*Cadillac*

## TECHNOPHILES, REJOICE.

Those who love technology will feel right at home in CTS, where drivers and passengers alike are surrounded by some of the most up-to-the-minute communications and entertainment systems available. With the touch of a button on the steering wheel and a simple voice command, standard Bluetooth® technology links to your Bluetooth-enabled mobile phone for easy, convenient hands-free calling. An eight-speaker Bose® sound system is also standard, as is XM Satellite Radio™,\* with its digital-quality sound and commercial-free music programming. Available options include a superb 10-speaker Bose 5.1 Cabin Surround® sound system and an advanced Navigation System complete with the largest telescoping touch screen in CTS's class.\*\* The Bose 5.1 sound system also includes a 40 gigabyte hard drive device that provides a host of functions, including pausing and rewinding live radio and importing songs from CDs. It's also designed for full iPod® integration, enabling your iPod play lists to appear on the vehicle's radio display and use of the steering-wheel-mounted controls.



### NAVIGATION SYSTEM

BELOW: The available Navigation System features a large, pop-up, high-resolution VGA touch screen. For optimal ease of use, directions to your destination can be downloaded from the OnStar® Centre† directly to your CTS's Navigation System.



### XM SATELLITE RADIO

RIGHT CENTRE: Your listening preferences are very personal. XM Satellite Radio gives you access to the largest playlist on the planet and the most commercial-free music in digital-quality sound. That's on top of news, talk, comedy and sports channels - including more than 1000 NHL games. It all adds up to 130 channels to choose from, coast to coast.\* Why offer so much choice? XM Satellite Radio has to appeal to a wide range of tastes, with more than 9 million subscribers. And it's included on all CTS models. Ask your dealer for more information.

\*Available in 10 Canadian provinces and the 48 contiguous United States. Subscription sold separately after trial period.

\*\*Based on 2009 Model Year competitive data for the GM Entry Luxury segment and latest competitive information available at time of printing.

### AUXILIARY INPUT

ABOVE: When you wish to listen to the music on your iPod via your CTS's excellent sound system, you'll find USB and auxiliary input jacks for that purpose conveniently located in the centre console.

†OnStar services require vehicle electrical system (including battery), wireless service and GPS satellite signals to be available and operating for features to function properly. OnStar acts as a link to existing emergency service providers. Subscription Service Agreement required. Ability to locate stolen vehicles varies with conditions. Call 1-888-4ONSTAR (1-888-466-7827) or visit onstar.ca for OnStar Terms and Conditions, Privacy Statement and details and system limitations.

*Cadillac*

# PERFORMANCE TO STIR THE SOUL.

For 2010, CTS Sedan and Sport Wagon feature a standard 3.0-litre V6 that's bristling with advanced features, including Direct Injection and Variable Valve Timing (VVT). These technologies result in a robust 270 horsepower, excellent fuel efficiency and all the refinement you associate with the Cadillac name. That's more standard horsepower than the BMW 3 Series and 5 Series, the Mercedes C-Class and E-Class and the Audi A4 and A6.\* And for CTS, it's just the beginning. There's also an available 3.6-litre V6 that shares the standard engine's cutting-edge engineering and pumps out a lusty 304 horsepower. As you would expect in a true driver's car, either of these sophisticated engines can be paired with your choice of a six-speed manual transmission\*\* or six-speed automatic transmission with Driver Shift Control.

\*Based on 2009 Model Year competitive data and the latest published information available at time of printing.

\*\*Not available on CTS Sport Wagon.



#### VARIABLE VALVE TIMING (VVT)

Standard on both CTS engines, Variable Valve Timing adjusts valve opening and closing times as engine speeds change, helping to optimize efficiency.



#### MOBIL 1® OIL

For outstanding engine protection even in severe conditions, both CTS engines are factory-filled with Mobil 1® oil featuring SuperSyn Technology™.



#### COMPRESSION RATIO

With a very high compression ratio of 11.7:1 and a host of high-tech features, the standard 3.0L V6 offers a tantalizing blend of performance, refinement and efficiency. And it does it all while requiring only regular-grade gasoline.

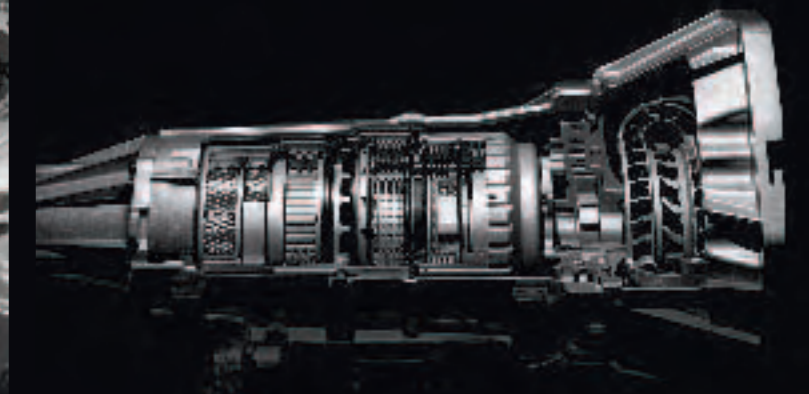

#### SHIFT CONTROL

In addition to Driver Manual Shift Control, CTS's precision-engineered 6-speed automatic transmission includes such advanced features as grade braking and Performance Algorithm Shifting, which automatically adjusts shift patterns whenever it detects that spirited driving is underway.

*Cadillac*

ITS ROAD MANNERS ARE IMPECCABLE.

Responsiveness. Steering feel. Body control. High-speed stability. These are the things that great handling is made of. How do you achieve them? First, engineer a solid body structure. Next, select only the finest chassis components, like a short/long arm front suspension, a multi-link rear suspension, a StabiliTrak® electronic stability control system and Michelin Pilot® and Pilot Sport® tires. Then the real work begins, testing and tuning and retesting and retuning on roads and racetracks around the world. If your engineers are extremely skillful – as the Cadillac team assuredly is – the result is a car that meets the highest driving standards in the world. A car, in fact, like CTS.



TRACK TESTED  
CTS prototypes were exhaustively tested at Germany's legendary Nürburgring and on public roads in North America and China.



V6-POWERED CTS MODELS OFFER A CHOICE OF 3 SUSPENSION TUNING LEVELS:

- The standard suspension offers a comfortable ride and agile handling.
- The FE2 Sport Suspension emphasizes handling responsiveness.
- The FE3 Performance Handling Suspension offers the ultimate in agility and body control.



# CTS 1, WINTER 0.

In the depths of our Canadian winters, poor visibility and slippery surfaces are frequent facts of life. CTS can help see you through with confidence and style. To help you find your way, there are available Xenon High-Intensity Discharge (HID) headlights that produce significantly more light than conventional bulbs. It's combined with an adaptive forward lighting system that turns the headlight beams as you steer through curves and corners, for even better visibility. CTS also offers a highly advanced All-Wheel-Drive (AWD) system, when on low-traction surfaces, it automatically redistributes torque to the wheels with grip to help keep you moving safely towards your destination.



### ALL-WHEEL DRIVE (AWD)

When grip is in short supply, CTS's AWD system alters the division of power as necessary to send the most torque to the wheels with the best traction. The result is a kind of sure-footedness you may never have experienced before in a luxury sport sedan.

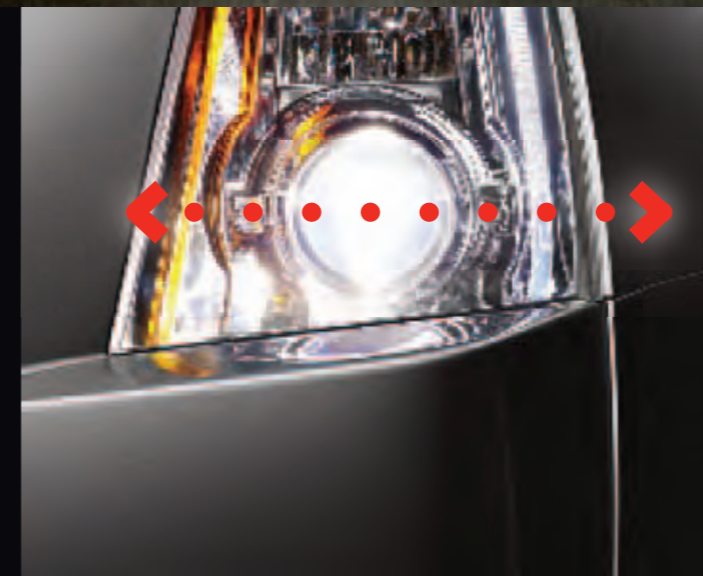

### ADAPTIVE HEADLIGHTS

The available adaptive forward lighting system helps you see around corners by steering the headlights in the direction you turn the wheel. The inside headlight adjusts by up to 5 degrees, while the outside headlight swivels a maximum of 15 degrees.

*Cadillac*



“... BY FAR THE MOST EXCITING  
CADILLAC EVER BUILT.”

– *caranddriver.com*, April 2009

The latest in Cadillac’s renowned V-series, CTS-V doesn’t just push the envelope, it tears it to shreds. This is not just the fastest, most powerful Cadillac in history, it’s the quickest-accelerating, most powerful V8-production sedan in the world. It’s also the first V8-powered production sedan ever to lap the merciless 22.8-kilometre Nürburgring Nordschleife racetrack in under eight minutes, a performance turned in, remarkably enough, by a car fitted with the available automatic transmission and regular production street tires. CTS-V also outperforms on the luxury front, with an elegant yet purposeful interior equipped with a full complement of intelligent amenities. Put it all together, with CTS-V you’ve got a car that prompted the experts at *Car and Driver* Magazine to write, “Get one while it lasts.”\*

\*caranddriver.com, April 2009



*Cadillac*

TOTAL LUXURY MEETS TOTAL CONTROL.

LED TRACERS

Light up CTS-V's awe-inspiring supercharged V8 and you'll see unique LED tracers circling the tachometer. They flash as a warning when the engine's speed nears the redline.



Ease into CTS-V's luxurious cockpit and you find yourself in a very serious driving environment indeed. The steering wheel and shifter can be trimmed in microfibre to help ensure a firm, secure grip, and there are standard sueded inserts in the seating areas to help keep you in place in performance driving. For an even higher level of comfort and support, 14-way power Recaro® heated and ventilated performance seats are available in a package that also includes track-inspired aluminum pedals. Add in luxurious amenities like full-leather seats and a Bose 5.1 Cabin Surround sound system and you have a car that sets new standards for sophistication and excitement alike.

RECARO SEATS

The available Recaro performance bucket seats feature pneumatic bolster controls and manually adjustable thigh support. They're also internally heated and ventilated for all-weather comfort.

## TECHNICAL DOMINANCE.

When it comes to numbers, CTS-V simply boggles the mind. Think 556 horsepower. 551 pounds-feet of torque. Zero to 96 km/h in a mere 3.9 seconds. And a Nürburgring lap time of 7 minutes and 59.32 seconds on regular production street tires. Making these impressive statistics possible are some of the most advanced engineering technologies in the automotive industry, like the race-inspired Performance Traction Management system that tailors torque delivery to ensure it matches the available grip, for optimal performance. Also noteworthy: CTS-V's Magnetic Ride Control®, the world's fastest-reacting suspension system. It adjusts shock absorber damping up to 1000 times per second so you enjoy razor-sharp handling with a controlled and surprisingly comfortable ride.



### TRANSMISSIONS

The available 6-speed automatic transmission includes Performance Algorithm Shifting and tap-up/tap-down Driver Shift Control with steering wheel paddle shifters. A Tremec 6-speed manual transmission is standard.



### BREMBO® BRAKES

Massive Brembo Brakes are standard on CTS-V. With 6-piston calipers up front and 4-piston calipers in the rear, stopping power is impressive, to say the least.



### REAR SPOILER

A uniquely styled rear deck-lid spoiler is one of the design touches that distinguish CTS-V. As in all Cadillac models, the centre high-mounted stoplight utilizes LEDs which light up faster and last longer than regular bulbs.

"... WHERE IT REALLY MATTERS, AS A PERFORMANCE SEDAN, THE CTS-V SOUNDLY SPANKS THE M5.

IT'S QUICKER IN A STRAIGHT LINE, HANDLES BETTER, STEERS BETTER, EVEN RIDES BETTER ..."

- motortrend.com, May 2009.

*Cadillac*

# MULTI-DIMENSIONAL PROTECTION.



## AIR BAGS

CTS is equipped with six air bags, including roof-mounted head curtain side-impact air bags that protect both front and rear occupants. The frontal air bags are dual-depth units that automatically adjust their deployment based on crash severity, seat position and other factors.



CTS has been carefully engineered and equipped to help you stay out of harm's way. With its logical controls, agile handling and excellent stopping power, CTS helps you avoid dangerous situations whenever possible. Every CTS also comes with an electronic stability control system – known as StabiliTrak – that's been proven to reduce your risk of a fatal single-vehicle crash by a remarkable 36 percent.\* Should a collision be unavoidable, front and rear crush zones and a solid steel safety cage help to direct dangerous energy away from the passenger compartment. CTS also features six standard air bags, along with front-seat safety belt pre-tensioners that pull the belts snug the instant a crash is detected, for improved protection. Your CTS even continues looking after you when the collision is over. If the air bags have deployed, a message is automatically sent to OnStar personnel\*\* who can dispatch emergency services as required.

\*According to information published by the U.S. Department of Transportation's National Highway Traffic Safety Administration, July 2007.



## ONSTAR

With OnStar\*\* and one year of the Directions & Connections Plan including Turn-by-Turn Navigation<sup>†</sup> CTS links you directly to the world's most comprehensive in-vehicle security, communications and diagnostics system.

\*\*OnStar services require vehicle electrical system (including battery), wireless service and GPS satellite signals to be available and operating for features to function properly. OnStar acts as a link to existing emergency service providers. Subscription Service Agreement required. Ability to locate stolen vehicles varies with conditions. Call 1-888-4ONSTAR (1-888-466-7827) or visit [onstar.ca](http://onstar.ca) for OnStar Terms and Conditions, Privacy Statement and details and system limitations.

<sup>†</sup>Turn-by-Turn Navigation not available in certain areas. Visit [onstar.ca](http://onstar.ca) for coverage map.

## CADILLAC OWNER PRIVILEGES

All luxury vehicle ownership experiences are not created equal. When you choose a new CTS, you enjoy an exclusive suite of Cadillac Owner Privileges which add to your safety and convenience and help to reduce your overall cost of ownership. You'll regard them as an extra measure of confidence in an uncertain world. For the first 4 years or 80,000 km of ownership,\* No-Charge Scheduled Maintenance will cover all regularly scheduled maintenance required by your Cadillac. During the same period, the New Vehicle Limited Warranty will cover all parts and labour costs\* that may be incurred to correct defects in material or workmanship. You are also covered by GM's Powertrain Component Limited Warranty, which is in effect for the first 5 years or 160,000 km of ownership.\*\* While the Powertrain Component Limited Warranty is in effect, you enjoy the support of Cadillac Roadside Assistance\* throughout Canada and the United States should you require towing, fuel delivery, a jump start or help with a flat tire or lock-out situation. In addition, Courtesy Transportation\* provides you with shuttle transportation for daily service and an alternate car (or reimbursement for rental or other transportation expenses) for overnight service, whenever your Cadillac requires scheduled maintenance or repairs covered under the New Vehicle Limited Warranty. Other Cadillac owner privileges include Trip Planning\* assistance and Trip Interruption Protection,\*\* and you may be reimbursed by General Motors of Canada for reasonable hotel, meal and alternative transportation expenses incurred should your trip be interrupted by a repair covered under the New Vehicle Limited Warranty. See your Cadillac dealer for complete details on all Cadillac Owner Privileges.

\*Program in effect for the first 4 years or 80,000 km (whichever comes first) of ownership. Conditions and limitations apply.

\*\*Whichever comes first, conditions and limitations apply.

## ACQUISITION OPTIONS

In addition to the many exclusive privileges of Cadillac ownership, General Motors of Canada has created a range of supplementary support programs to enhance your ownership experience. Some of these programs assist you in purchasing the Cadillac of your choice. Others help protect you and your new Cadillac over the long term.

### Purchasing:

- **GMAC Express Credit Application** – a convenient way to get pre-approved credit towards the purchase of your next GM vehicle
- **GMAC Purchase Financing** – on-the-spot financing at your GM dealership<sup>†</sup>
- **The GM Card** – eligible cardholders may be able to redeem up to \$3500 in GM Card<sup>®</sup> Earnings toward the Total Purchase Price on selected vehicles.<sup>††</sup> For more information on The GM Card please call 1-800-461-3279.

### Additional Ownership Programs:

- **GM Protection Plan (GMPP)** – the only extended service plan backed by the resources and commitment of General Motors, GMPP may be purchased at the time of sale or subsequently during the New Vehicle Limited Warranty period.<sup>††</sup>

<sup>†</sup> Subject to eligibility. <sup>††</sup> Conditions and limitations apply.

### Information Resources:

You can obtain more information about Cadillac vehicles and programs from your Cadillac dealer, or at these information centres:

- The GM Website at [gm.ca](http://gm.ca)
- The Cadillac Contact Centre at **1-888-446-2000** or **(1-800-263-3830** for TDD users)  
For more information about GMAC visit [gmac.gm.ca](http://gmac.gm.ca) or call **1-800-616-4622**.

## A word about this brochure

Some of the equipment shown or described throughout this brochure may be available at extra cost. We have tried to make this brochure comprehensive and factual. We reserve the right, however, to make changes at any time, without notice, in prices, colours, materials, equipment, specifications, models and availability. Specifications, dimensions, measurements, ratings and other numbers in this brochure and other printed materials provided at the dealership or affixed to vehicles are approximates based upon design and engineering drawings and prototypes and laboratory tests. Your vehicle may differ due to variations in manufacture and equipment. Since some information may have been adapted since the time of the printing, please check with your Cadillac dealer for complete details. General Motors of Canada Limited reserves the right to lengthen or shorten the model year for any product, for any reason, or to start and end model years at different times.

## A word about assembly

Cadillac vehicles are equipped with engines and components produced and assembled by different operating units of General Motors, its subsidiaries and suppliers and these engines and components may change or be obtained from different sources from time to time. All such engines and components are approved for use in Cadillac vehicles. Certain equipment ordered may be unavailable at the time of assembly and we suggest that you verify that your vehicle includes the equipment you ordered, or if there are changes, that they are acceptable to you.

## A word about corrosion

Cadillacs are designed and built to resist corrosion. All body sheet metal components are warranted against rust-through corrosion for 6 years. There is no deductible for rust-through repairs. Application of additional rust-inhibiting materials is not required under the corrosion coverage and none is recommended.

## Trademarks

The marks appearing in this Cadillac brochure including, but not limited to: General Motors, GM, the GM Canada emblem, Cadillac, the Cadillac badge, Cadillac Owner Privileges, Cadillac Roadside Service, CTS, V-Series emblem and their respective logos, emblems, slogans and vehicle model names and body designs; and other marks such as Magnetic Ride Control, Solar-Ray, StabiliTrak and Twilight Sentinel are trademarks of General Motors and/or General Motors of Canada Limited, its subsidiaries, affiliates or licensors.

GMAC is a registered trademark of the General Motors Acceptance Corporation of Canada, Limited.

OnStar and the OnStar emblem are registered trademarks of the OnStar Corporation.

TheftLock is a registered trademark of Delphi Automotive Systems.

Bose and Cabin Surround are trademarks or registered trademarks of the Bose Corporation.

Radio Data System (RDS) is a registered trademark of the U.S. National Association of Broadcasters.

The XM name and related logos are trademarks of XM Canada, Canadian Satellite Radio, Inc.

Apple and iPod are trademarks of Apple Computer Inc., registered in the U.S. and other countries.

Bluetooth is a registered trademark of Bluetooth SIG Inc.

Brembo is a registered trademark of Brembo S.p.A.

Michelin Pilot and Pilot Sport are registered trademarks of Michelin North America Inc.

Mobil 1 and SuperSyn Technology are registered trademarks of Exxon Mobil Corporation.

Recaro is a registered trademark of RECARO GmbH & Co.

## Copyright

© Copyright 2009 General Motors of Canada Limited. All Rights Reserved. All text, images, graphics, and other materials in this Cadillac brochure are subject to the copyright and other intellectual property rights of General Motors and/or General Motors of Canada Limited. These materials may not be reproduced, distributed or modified without the express written permission of General Motors and/or General Motors of Canada Limited.



# 2010 CTS FEATURES & OPTIONS

## SAFETY AND SECURITY

	CTS 3.0L SEDAN/SPORT WAGON	CTS 3.6L SEDAN/SPORT WAGON	CTS-V
<b>AIR BAGS</b>			
Driver and front-passenger, dual-stage, frontal, passenger-side dual-depth with automatic air bag suppression Passenger Sensing System	S	S	S
Driver and front-passenger, seat-mounted side-impact	S	S	S
Front-to-rear, head curtain side-impact	S	S	S
<b>DOOR LOCKS</b>			
Automatic power, programmable with lock-out protection	S	S	S
Rear-door, child-security	S	S	S
<b>HEADLIGHTS</b>			
Daytime Running Lights, automatic light control with Twilight Sentinel®	S	S	S
Windshield wiper activated	S	S	S
Tungsten halogen	S	S	–
Xenon High-Intensity Discharge (HID) with adaptive forward lighting	0¹/0²	S	S
Headlight washers	–	–	S
<b>KEYLESS ENTRY SYSTEM</b>			
Remote, includes personalization with activation notification and Panic feature	S	S	–
<b>KEYLESS ACCESS SYSTEM</b>			
Remote, includes adaptive remote vehicle starter system,³ keyless ignition start and lock/unlock passive entry	0⁴	0⁴	S
<b>ONSTAR SYSTEM</b>			
OnStar In-Vehicle Communications and Assistance Service, includes 1 year of the Directions & Connections Plan* with Turn-by-Turn Navigation**	S	S	S
<b>SAFETY RESTRAINTS</b>			
LATCH (Lower Anchors and top Tethers for Children), rear seats	S	S	S
<b>STABILITRAK</b>			
StabiliTrak electronic stability control system	S	S	S
<b>THEFT-DETERRENT SYSTEM</b>			
Electronic immobilizer	S	S	S
Theft-deterrent alarm for doors and trunk, audible/visible alarm	0⁵	0⁵	S
<b>TRACTION CONTROL</b>			
Electronic, full-function, all-speed with on/off switch	S	S	S
<b>ULTRASONIC REAR PARKING ASSIST</b>			
Rear obstacle detection system with audible/visible warning	0⁴	0⁴	S
<b>MECHANICAL</b>			
<b>BRAKES</b>			
Power, 4-wheel vented discs	S	S	–
Brembo high performance 6-piston front/4-piston rear calipers with vented discs	–	–	S
4-wheel, 4-channel anti-lock braking system (ABS) with Panic Brake Assist and Dynamic Rear Brake Proportioning	S	S	S
Performance Braking System	–/0²,⁶	0⁷,⁸/S¹,¹⁰	–
<b>DIFFERENTIAL</b>			
Rear, locking, limited-slip	–/0²,¹¹	0⁷/S¹¹	S
<b>DRIVE</b>			
Rear-wheel drive	S¹²	S¹²	S
All-wheel drive	S⁹	S⁹	–
<b>ENGINES</b>			
3.0L V6 VVT with Direct Injection 270 horsepower @ 7000 rpm and 223 lb.-ft. of torque @ 5700 rpm	S	–	–
3.6L V6 VVT with Direct Injection 304 horsepower @ 6400 rpm and 273 lb.-ft. of torque @ 5200 rpm	–	S	–
6.2L LSA Supercharged V8 with SFI 556 horsepower @ 6100 rpm and 551 lb.-ft. of torque @ 3800 rpm	–	–	S
Block heater	0	0	0
<b>EXHAUST SYSTEM</b>			
Dual, stainless steel with chrome tips	S	S	S
<b>STEERING</b>			
Power-assisted, rack-and-pinion, speed-sensitive	S	S	S
<b>SUSPENSION</b>			
4-wheel independent	S	S	S
Sport Suspension	0¹/0²	S	–
Magnetic Ride Control Sport Suspension	–	–	S
<b>PERFORMANCE PACKAGE</b>			
Includes Sport Suspension (FE2), 18" x 8" premium multi-coat painted aluminum wheels (B), P235/50R18 V-rated all-season tires,¹ fog lights, Xenon High-Intensity Discharge (HID) headlights with adaptive forward lighting system (wheels can be upgraded to 19" high-polished aluminum wheels)	0/0²	S	–
<b>SPORT PACKAGE</b>			
Includes Performance Handling Suspension (FE3), automatic rear-level control, performance braking system, performance speed-sensitive steering, steering-wheel-mounted paddle shift transmission controls,² performance cooling system,³ 19" x 8.5" high-polished aluminum wheels (D), P245/45ZR19 Y-rated summer performance tires,¹¹ (Sedan model also includes – limited-slip differential)⁹,¹³	–	0	–

## MECHANICAL (Continued)

	CTS 3.0L SEDAN/SPORT WAGON	CTS 3.6L SEDAN/SPORT WAGON	CTS-V
<b>TRANSMISSION</b>			
6-speed manual, Aisin	S¹⁴/–	0¹⁵/–	–
6-speed manual, Tremec with short-throw shifter	–	–	S
6-speed automatic with Driver Shift Control¹⁶	0/S	S	–
6-speed automatic with steering-wheel-mounted paddle shift controls	–	0⁷	0
<b>INTERIOR</b>			
<b>AUDIO SYSTEMS</b>			
AM/FM stereo with CD player, MP3 compatibility, Radio Data System® (RDS), TheftLock® and Bose 8-speaker sound system	S	–	–
Same as above, plus in-dash 6-disc CD changer	0⁵	–	–
AM/FM stereo with CD/DVD player, MP3 compatibility, Radio Data System (RDS), 40 GB Hard Drive Device (HDD), USB and audio connectivity, TheftLock and Bose 10-speaker 5.1 Cabin Surround sound system	–	S	–
Same as above, plus Navigation System with 40 GB Hard Drive Device (HDD) based navigation for map coverage² in Canada and USA, pop-up touch screen, voice and/or text guidance, DVD audio/video capabilities (vehicle in Park position only) and voice recognition	0¹⁷	0	S
Bluetooth in-vehicle system allows Bluetooth-enabled mobile phones to utilize vehicle's audio system, microphone, voice recognition and steering wheel controls	S	S	S
XM Satellite Radio¹¹	S	S	S
<b>CLIMATE CONTROL</b>			
Automatic, dual-zone electronic climate controls	S	S	S
Air filtration system	S	S	S
Automatic cabin odour filtration system	0⁴	0⁴	S
<b>CONSOLES</b>			
Front centre floor console with storage and dual cupholders	S	S	S
Overhead, includes front map lights	S	S	S
<b>CRUISE CONTROL</b>			
Electronic with resume, coast and decelerate/accelerate features	S	S	S
<b>INSTRUMENTATION</b>			
Analogue with Driver Information Centre	S	S	S
Tire pressure monitoring system	S	S	S
<b>LIGHTING</b>			
Illuminated entry/exit, rear courtesy reading, front map and trunk	S	S	S
Ambient lighting system with LED light pipes and spotlights	0⁵	0⁵	S
<b>MIRRORS</b>			
Electrochromic, auto-dimming rear-view mirror with OnStar controls	S	S	S
Illuminated driver and front-passenger visor vanity mirrors	S	S	S
<b>SEATING</b>			
Front buckets with leather seating surfaces, power 8-way driver and front-passenger seat adjusters and power 2-way lumbar adjusters includes articulating active head restraints and seatback map pockets	S	S	–
Front buckets with full leather seats and sueded inserts, power 8-way driver and front-passenger seat adjusters and power 2-way lumbar adjusters includes articulating active head restraints and seatback map pockets	–	–	S
Heated front bucket seats	S	S	S
Heated and ventilated front bucket seats	0⁴	0⁴	–
Recaro heated and ventilated power 14-way performance front bucket seats (includes sport metal pedals)	–	–	0
Rear seatback, fixed back with armrest pass-through and cupholders	S/–	S/–	S
Rear seatbacks, 60/40 split-folding	0⁴/S	0⁴/S	–
<b>STEERING WHEEL</b>			
Leather-wrapped	S	S	S
Suede-wrapped¹⁸	–	–	0
Switches for audio system, climate controls, programmable function controls for fan, traction control, phone, phone end and navigation repeat	S	S	S
Manual tilt and telescopic adjustable column	S	S	–
Power tilt and telescopic adjustable column with memory	0⁴	0⁴	S
<b>TRUNK/CARGO AREA</b>			
Cargo convenience net	S/0⁵	S/0⁵	S
Power remote release	S/–	S/–	S
<b>UNIVERSAL HOME REMOTE</b>			
3-channel programmable remote transmitter	S	S	S
<b>WINDOWS</b>			
Power with express-up and down on front windows with pinchguard and express-down feature on rear windows with window lock-out	S	S	S
<b>LUXURY I PACKAGE</b>			
Includes theft-deterrent system with audible/visible alarm and interior ambient lighting system with LED light pipes and spotlights (Sport Wagon models also include – heavy-duty cargo convenience net/pet guard and retractable cargo shade)	0¹⁹	0	–
<b>LUXURY II PACKAGE</b>			
Includes heated and ventilated front bucket seats, power tilt and telescopic adjustable steering column, automatic cabin odour filtration system, ultrasonic rear parking assist and keyless access system with remote vehicle starter system³ (Sedan models also include – 60/40 split-folding rear seatbacks)	0²⁰	0	–

## INTERIOR (Continued)

	CTS 3.0L SEDAN/SPORT WAGON	CTS 3.6L SEDAN/SPORT WAGON	CTS-V
<b>MEMORY/PERSONALIZATION PACKAGE</b>			
Automatically recalls settings for 2 drivers based on their individual remote keyless entry key fob; the recall function remembers the position of the driver's seat, exit seating position, exterior rear-view mirror preferences and passenger tilt-down parallel park feature, climate control settings and radio station pre-sets. Customer ability to program: Driver's name, Twilight Sentinel delay, remote activation verification, perimeter lighting, auto door lock mode, delayed door locking, passenger window lock-out and chime volume	S	S	S
<b>PERFORMANCE LUXURY PACKAGE</b>			
Includes Luxury I Package, Luxury II Package and Wood Trim Package	–/0	–/0	–
<b>WOOD TRIM PACKAGE</b>			
Includes Sapele Pommele wood accents on steering wheel, shifter, instrument panel, centre console and doors	0	0	–
Includes Midnight Sapele Pommele wood accents on instrument panel, centre console and doors	–	–	0
<b>EXTERIOR</b>			
<b>GLASS</b>			
Solar-Ray®, tinted	S	S	S
<b>LIFTGATE</b>			
Power programmable liftgate, height adjustable	–/S	–/S	–
<b>LIGHTS</b>			
Fog lights	0¹/0²	S	S
Tail lights, LED	S	S	S
<b>MIRRORS</b>			
Foldaway, heated, power remote control	S	S	S
<b>REARVIEW CAMERA SYSTEM</b>			
Reverse assist for parking²¹	–/0	–/0	–
<b>ROOF RACK</b>			
Double cross bows	–/0	–/0	–
<b>SUNROOF</b>			
UltraView roof with power tilt and, sliding glass panel with power sunshade over front and rear seats with variable position and express-open/close feature	0	0	0
<b>TIRES</b>			
P235/55R17 H-rated, all-season¹	S	–	–
P235/50R18 V-rated, all-season¹	0¹/0²	S	–
P245/45ZR19 Y-rated, summer performance¹¹	–	0⁷,⁸	–
P255/40R19 front and P285/35R19 rear; W-rated, summer performance¹¹	–	–	S
<b>WHEELS (Shown on Page 35)</b>			
17" x 8" painted aluminum (A)	S	–	–
18" x 8" premium multi-coat painted aluminum (B)	0¹/0²	S	–
18" x 8" high-polished aluminum (C)	0²²	0²²	–
19" x 8.5" high-polished aluminum (D)	–	0⁷	–
19" x 9" front, 19" x 9.5" rear painted aluminum (E)	–	–	S
19" x 9" front, 19" x 9.5" rear polished aluminum (F)	–	–	0
<b>WIPER/WASHER SYSTEM</b>			
2-speed with variable delay (intermittent)	S	S	S
<b>CTS SPORT WAGON PREFERRED EQUIPMENT GROUPS (PEGs)</b>			
<b>LUXURY I PACKAGE</b>			
Includes in-dash 6-disc CD changer, theft-deterrent system with audible/visible alarm and interior ambient lighting system with LED light pipes and spotlights, heavy-duty cargo convenience net/pet guard and retractable cargo shade	•	•	•
<b>WOOD TRIM PACKAGE</b>			
Sapele Pommele wood accents on steering wheel, shifter, instrument panel, centre console and doors	•	•	•
<b>BRAKES</b>			
Performance Braking System¹¹	•	•	S
<b>PERFORMANCE PACKAGE</b>			
Includes Sport Suspension (FE2), 18" x 8" premium multi-coat painted aluminum wheels (B), P235/50R18 V-rated all-season tires; fog lights, Xenon High-Intensity Discharge (HID) headlights with adaptive forward lighting system (AWD model also includes – limited-slip differential)	•	•	S
<b>LUXURY II PACKAGE</b>			
Includes heated and ventilated front bucket seats, power tilt and telescopic adjustable steering column, automatic cabin odour filtration system, ultrasonic rear parking assist and keyless access system with remote vehicle starter system	•	•	•
<b>NAVIGATION SYSTEM</b>			
Navigation map coverage² in Canada and USA, HDD-based navigation, pop-up touch screen, voice and/or text guidance, DVD audio/video capabilities (vehicle in Park position only) and voice recognition	•	•	•
<b>REARVIEW CAMERA SYSTEM</b>			
Reverse assist for parking	•	•	•
<b>SUNROOF</b>			
UltraView roof with power tilt and sliding glass panel with power sunshade over front and rear seats with variable position and express-open/close feature	•	•	•

## DIMENSIONS

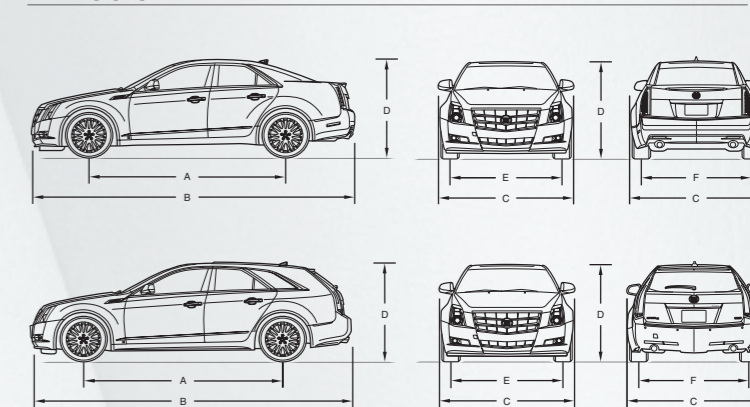

EXTERIOR DIMENSIONS	SEDAN	SPORT WAGON
Wheelbase (A)	2880 mm (113.4 in.)	2880 mm (113.4 in.)
Length (B)	4866 mm (191.6 in.)	4859 mm (191.3 in.)
Width (C)	1841 mm (72.5 in.)	1841 mm (72.5 in.)
Height (D)	1472 mm (58.0 in.)	1480 mm (58.3 in.)
Front track (E)	1570 mm (61.8 in.)	1570 mm (61.8 in.)
Rear track (F)	1575 mm (62.0 in.)	1575 mm (62.0 in.)
<b>INTERIOR DIMENSIONS</b>		
Headroom		
Front/rear	986/944 mm (38.8/37.2 in.)	986/944 mm (38.8/37.2 in.)
Legroom		
Front/rear	1077/913 mm (42.4/35.9 in.)	1077/913 mm (42.4/35.9 in.)
Shoulder room		
Front/rear	1441/1390 mm (56.7/54.7 in.)	1441/1390 mm (56.7/54.7 in.)
Hip room		
Front/rear	1400/1375 mm (55.1/54.1 in.)	1400/1375 mm (55.1/54.1 in.)
Seating capacity	5	5

CAPACITIES	SEDAN	SPORT WAGON
Fuel	68 L (14.9 imp. gal.)	68 L (14.9 imp. gal.)
Cargo volume	385 L (13.6 cu. ft.)	720 L (25.4 cu. ft.)
-2nd-row seats folded down	–	1643 L (58.0 cu. ft.)
Towing*	454 kg (1000 lb.)	454 kg (1000 lb.)

CURB WEIGHT, ESTIMATED	SEDAN	SPORT WAGON
3.0L with manual transmission (RWD)	1753 kg (3865 lb.)	–
3.0L with automatic transmission (RWD)	1753 kg (3865 lb.)	1828 kg (4030 lb.)
3.0L with automatic transmission (AWD)	1839 kg (4054 lb.)	1915 kg (4222 lb.)
3.6L with manual transmission (RWD)	1794 kg (3955 lb.)	–
3.6L with automatic transmission (RWD)	1775 kg (3913 lb.)	1851 kg (4081 lb.)
3.6L with automatic transmission (AWD)	1868 kg (4118 lb.)	1955 kg (4310 lb.)
CTS-V with manual transmission	1909 kg (4209 lb.)	–
CTS-V with automatic transmission	1924 kg (4241 lb.)	–

\*Includes weight of trailer, cargo, passengers and equipment. All towing recommendations are subject to change. Trailer tongue load should be 10% of the maximum trailer weight but should never exceed the load rating for that vehicle, engine or hitch combination. See your dealer or refer to the CTS Owner's Manual for details.

- S – Standard. 0 – Optional individually or in combination with other optional equipment.
- – Included in Preferred Equipment Group (PEG).
  - 1. Included with available Performance Package.
  - 2. Included with available Performance Package in PEG 15F.
  - 3. Included with automatic transmission only.
  - 4. Included with available Luxury II Package.
  - 5. Included with available Luxury I Package.
  - 6. Available on All-Wheel Drive (AWD) model only.
  - 7. Included with available Sport Package.
  - 8. Available on Rear-Wheel Drive (RWD) model only.
  - 9. Standard on All-Wheel Drive (AWD) model only.
  - 10. Available on Rear-Wheel Drive model.
  - 11. Included with All-Wheel Drive (AWD) model only.
  - 12. Standard on Rear-Wheel Drive (RWD) model only.
  - 13. Not available with Performance Package.
  - 14. Standard on Rear-Wheel Drive (RWD) model only. All-Wheel Drive (AWD) model equipped with 6-speed automatic transmission only.
  - 15. Requires available Sport Package.
  - 16. Includes Grade Braking and Performance Algorithm Shifting.
  - 17. Deletes in-dash 6-disc CD changer when available Luxury I Package is ordered.
  - 18. Requires available Recaro Performance Seat, includes sueded shifter.
  - 19. Includes in-dash 6-disc CD changer.
  - 20. Requires available Luxury I Package.
  - 21. Requires available Luxury II Package and Navigation Audio System.
  - 22. Requires available Performance Package.
- \* OnStar services require vehicle electrical system (including battery), wireless service and GPS satellite signals to be available and operating for features to function properly. OnStar acts as a link to existing emergency service providers. Subscription Service Agreement required. Ability to locate stolen vehicles varies with conditions. Call 1-888-4ONSTAR (1-888-466-7827) or visit onstar.ca for OnStar Terms and Conditions, Privacy Statement and details and system limitations.
- \*\* Turn-by-Turn Navigation not available in certain areas. Visit onstar.ca for coverage map.
- † All-season tires may not satisfy winter tire requirements in all regions of the country. Tires specifically designed for severe winter conditions and marked with the "winter tire" symbol ❄️ may be required during certain months or in certain regions. Contact your Provincial, Municipal or local road authority for information regarding which tires are required in your particular area.
- †† Installation of four winter tires recommended for winter driving conditions.
- ‡ At time of print, detailed map coverage is available for most major urban areas of the United States and for certain metropolitan areas of Canada (Vancouver, Calgary, Edmonton, Winnipeg, Windsor, London, Toronto, Ottawa, Montreal, Quebec City and Halifax). Coverage is significantly limited outside these areas.
- ‡‡ Available in 10 Canadian provinces and the 48 contiguous United States. Subscription sold separately after trial period.



# INTERIOR FABRIC COLOURS

# EXTERIOR COLOURS

The exterior and interior colours in this brochure are as close to the actual vehicle production colours as the printing process allows. For more accurate colour samples, ask your Cadillac sales consultant to see the dealer showroom vehicle colour display.  
\*Available at extra cost.



AFC – Ebony Leather

AFE – Cashmere Leather

AFD – Light Titanium Leather

AFF – Ebony Leather with Sueded Insert

AFG – Ebony Leather with Cashmere Sueded Insert

AFH – Light Titanium Leather with Sueded Insert



GAN – Radiant Silver

GBN – White Diamond Tricoat<sup>4</sup>

GIM – Vanilla Latte<sup>2</sup>

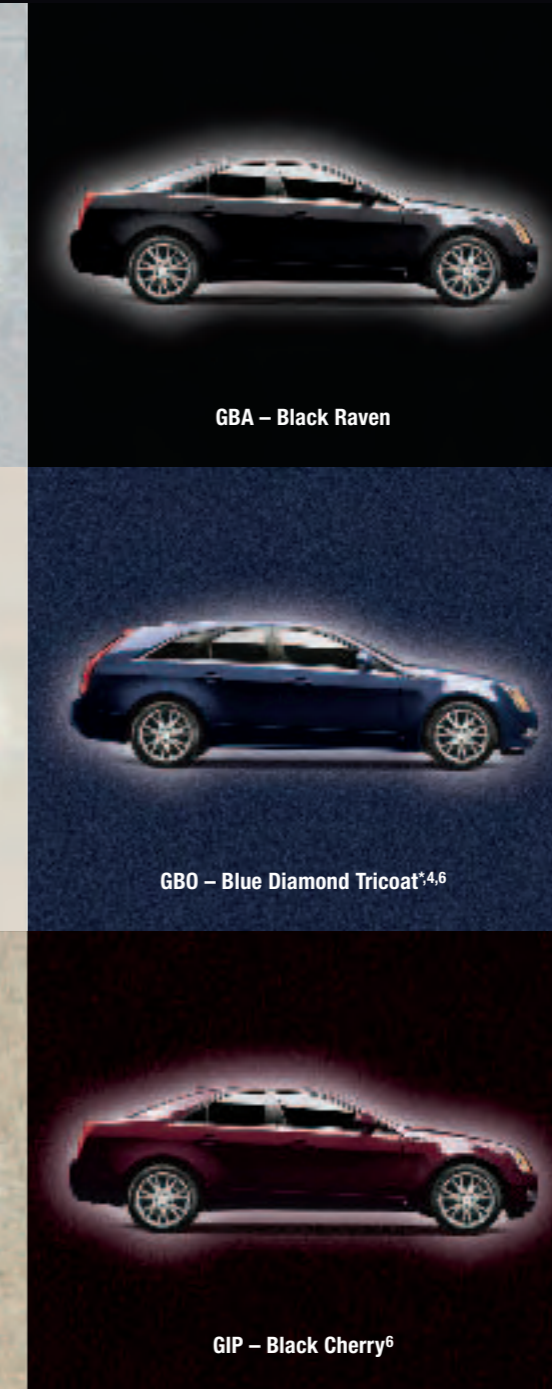

GBA – Black Raven

GBO – Blue Diamond Tricoat<sup>4,6</sup>

GIP – Black Cherry<sup>6</sup>



GGX – Tuscan Bronze ChromaFlair<sup>2,5</sup>

GLH – Thunder Gray ChromaFlair<sup>5</sup>

# EXTERIOR/INTERIOR COLOUR COMPATIBILITY

Exterior Colours	Interior Colours	Ebony with Ebony Accents	Ebony with Cashmere Inserts <sup>1</sup>	Cashmere with Cocoa Accents <sup>2</sup>	Light Titanium with Ebony Accents
GAN – Radiant Silver		•	•	•	•
GBA – Black Raven		•	•	•	•
GBE – Crystal Red Tintcoat <sup>3</sup>		•	•	•	•
GBN – White Diamond Tricoat <sup>4</sup>		•	•	•	•
GBO – Blue Diamond Tricoat <sup>4,6</sup>		•	•	•	•
GGX – Tuscan Bronze ChromaFlair <sup>2,5</sup>		•	•	•	•
GIM – Vanilla Latte <sup>2</sup>		•	•	•	•
GIP – Black Cherry <sup>6</sup>		•	•	•	•
GLH – Thunder Gray ChromaFlair <sup>5</sup>		•	•	•	•

\* Available at extra cost.  
1 – Available on CTS-V only.  
2 – Not available on CTS-V.  
3 – Tintcoat is a premium two-layer paint application with the addition of a tinted clearcoat, lending the finish an extra depth and brightness.

4 – Tricoat is a meticulous three-layer process that results in a dramatic hue-shifting colour reminiscent of a show-car finish.  
5 – ChromaFlair<sup>®</sup> uses advanced light-interference technology and prismatic metallic pigments to create an intense, deeply lustrous colour.  
6 – Available on CTS Sedan only.

# WHEELS

- A – 17" x 8" painted aluminum wheel
- B – 18" x 8" premium multi-coat painted aluminum wheel
- C – 18" x 8" high-polished aluminum wheel
- D – 19" x 8.5" high-polished aluminum wheel
- E – 19" painted aluminum wheel
- F – 19" polished aluminum wheel





## WE'LL TAKE YOU EXACTLY WHERE YOU WANT TO GO.

You demand more from a vehicle than ever before. Exactly the same can be said of Cadillac. For starters, you're looking for greener driving choices – Cadillac offers a range of vehicles powered by hybrid technology or alternative fuels. And many incorporate technology that helps reduce fuel consumption and emissions, like Active Fuel Management®, Variable Valve Timing and Direct Injection. Down the road, there are plug-in electric vehicles and other emerging technologies that point the way to a future of zero-emissions driving.

At Cadillac, we take pride in more than the quality of our vehicles. We are also proud to be the Official Vehicle Supplier of the Vancouver 2010 Olympic and Paralympic Winter Games. To help create a more sustainable 2010 Winter Games, we are committed to providing the most environmentally friendly fleet of all time through the supply of hybrid, alternate fuel, and other advanced green technology vehicles. The Drive is On.

For more information about Cadillac visit [cadillac.gm.ca](http://cadillac.gm.ca)



\*Cadillac is a brand of General Motors of Canada, the Official Vehicle Partner of the Vancouver 2010 Olympic and Paralympic Winter Games.™© 2009, VANOC. Used under License.



192-10-B-001E