

1984

# The Audi Coupé



# The 1984 Audi Coupé

Inside every Audi Coupé GT you'll find the impossible. Accommodation for 5 full sized adults. 15.6 cubic feet for luggage. A new 2.0 litre, 5 cylinder fuel injected engine. 5 speed gearbox. 0 - 60 in 9.9 secs. Top speed 115 mph. Electric windows, power steering, central locking doors. And, of course, the alternative of a 130 bhp fuel injection engine. 5 speed gearbox. 0 - 60 in just 9.1 seconds. Top speed 122 mph. And a steel sunshine roof as standard.

It all adds up to the end of the cliché Coupé.





This brochure is intended to show the general appearance of the two Audi Coupé GT models. Please note that for the 1984 model year a nearside rear view mirror is fitted. The illustrations in the brochure do not show this feature.

During the origination of this brochure, the manufacturer's illustrations depicted left hand drive vehicles. However, to facilitate the brochure's application within the United Kingdom, the illustrations have undergone a process that makes possible the presentation of right hand drive vehicles. The process involves the "reversing" of negatives and as a result some minor items of specification have become slightly mispositioned.

**Due to a continuous process of modification by the manufacturer, some change in specification may occur after the publication of this brochure. Kindly confirm specification with your authorised Audi dealer at the time of placing your order.**

The pages dealing with the summary of specification give exact details of equipment at the time of publication.

The details given in this brochure relate to models of the 1984 model year.



# More jazz, less juice.

The Audi Coupé is the only five cylinder Coupé in the world. Why five cylinders? To begin with, a five cylinder engine combines

incredible smoothness with the kind of economy we need today. There are two engines which power the Coupé - a new 1994 cc with

fuel injection and the powerful 2144 cc fuel injected motor. Both give excellent power at low speed. At high speeds noise remains

amazingly low.

Audi five cylinder engines offer better weight to performance ratios than six cylinder engines.



And weight together with shape is a major factor in saving fuel.

For optimum utilisation of fuel, the Audi Coupés use electronically controlled ignition and five speed gearboxes as standard equipment.

Carefully chosen gear ratios match the characteristics of the engines. Besides extracting maximum performance while under acceleration, the ratios provide economy in their own

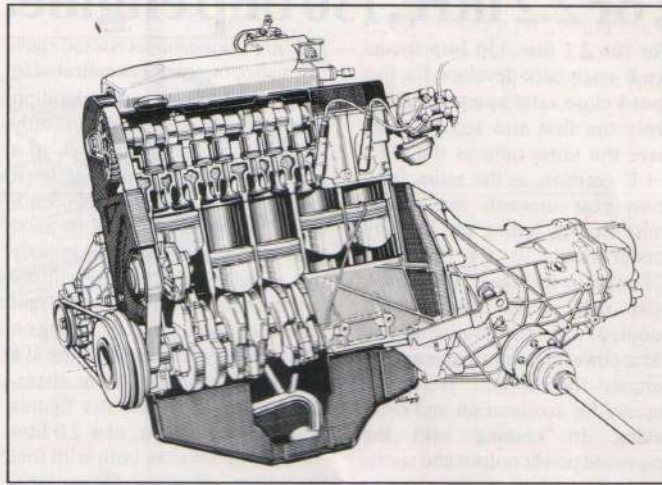

*On the GT, the powerful five-cylinder injection engine with an output of 115 bhp (85 kW).*

right while cruising. This care in selecting gearbox ratios is further reflected in noise reduction and increased mechanical durability.

As an alternative, an automatic transmission is available, as an option, with the 2.0 litre engine.

The new 2.0 litre five cylinder fuel injected engine has an output of 115 bhp DIN and a capacity of 1994 cc. The acceleration figures give you an idea of its performance. 0 - 50 mph in 6.5 secs, 0 - 60 mph in 9.9 secs. A high torque of 165 Nm is obtained at a rev. speed of 3200 rpm.

You never know when you may need that kind of pulling power.



# Racy but spacey. The new 2,0 litre fuel injection engine; or 2.2 litre, 130 bhp engine.

The new 2.0 litre fuel injection engine; or 2.2 litre, 130 bhp engine.

The combination of stylish exterior, roomy interior, advanced engineering with economy make the Coupé GT virtually unique. The Coupé has been further improved by a new 2.0 five cylinder fuel injected engine, as well as the powerful 130 bhp version.

Traditionally, fuel injection has always been fitted to gain performance, it also provides excellent fuel management and this means greater control resulting in benefits in economy and performance.

The capacity of the new 2.0 litre engine is 1994 cc and with the fuel injection system it develops some very desirable torque figures. 165 Nm at 3200 rpm means low down pulling power and continuous performance right up the rev. range.

These characteristics do away with unnecessary gear-changing and make caravan towing or trailer towing an effortless task, for both 2.0 litre and 2.2 litre 130 bhp versions.

For the 2.2 litre 130 bhp model Audi engineers developed a five speed close ratio sports gearbox. Only the first and second gears have the same ratio as the GT's 4+E gearbox, as the ratios from third gear upwards are spaced more closely, letting the 130 bhp model reach its top speed of 122 mph in fifth gear, just below peak rpm. With this gearbox, coupled with the availability of extra power and impressive engine torque, there's still plenty in reserve for acceleration and overtaking. In keeping with the improved power output and sports gearbox, the brakes and running gear have been modified. The front discs are ventilated for maximum braking performance and the suspension revised, with stronger drive shaft joints and stiffer shock absorbers. Although the

2.2 litre Coupé model is totally performance oriented - as reflected in the electrifying acceleration figures of 0-50 mph in only 6.3 seconds and 0-60 mph in a mere 9.1 - speed has not been achieved at the expense of economy. The combination of its good power to weight ratio and miserly yet totally reliable 5 cylinder engine help return impressive fuel consumption figures. 22.2 mpg on the urban cycle and 38.2 mpg at a steady 56 mph speak for themselves. But don't let the figures alone convince you; new 2.0 litre or 130 bhp version, both with fuel injection - try them for yourself.



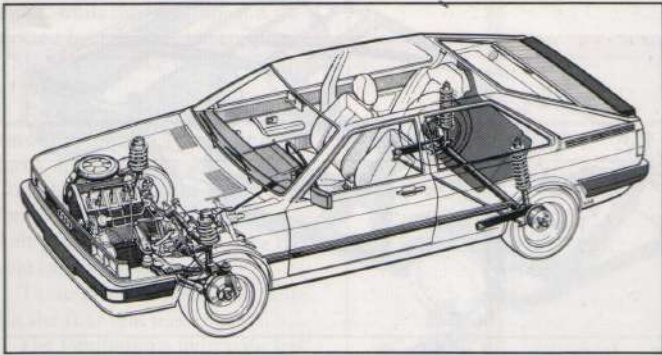

Please note that for the 1984 model year a rear window wash/wipe system is fitted as standard equipment.

# Safety first.

The Audi Coupé has safety built into it, an integral part of its Audi pedigree. In fact, you'll find the same pre-occupation with safety in the new Coupé that you've come to expect from each and every Audi before it, the Audi 80, 100 and Quattro.

The Coupé incorporates many advanced safety features. Like self-stabilising steering with negative roll radius.

We have paid special attention to passenger safety in various types of accidents.

Results of our comprehensive programme of crash tests have led us to design the rigid-cell passenger compartment with crumple zones in front and at the rear. These zones will absorb much of the impact if a collision should occur. Safety locks help stop the doors bursting open in the event of an accident.

As in all Audi models, the instrument panel is made of resilient material and has rounded contours to make an important contribution to minimising the risk of injury.

Driver impact on the steering column is minimised by a sheer-

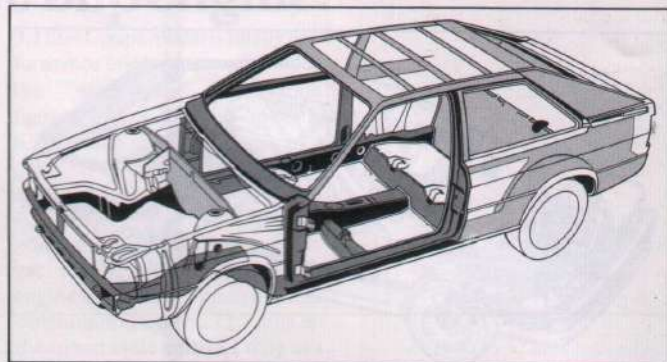

*The rigid passenger cell compartment with crumple zones front and rear.*



off-plate and a flexible mesh element, while outside impact is deflected by a detachable coupling. This helps reduce the possibility of injury.

For further safety, the seats are firmly anchored. The front seats have adjustable head restraints and three-point seat belts with locks which guarantee optimum belt position no matter how the seats are adjusted.

There are also three seat belts for the rear seat passengers.

The laminated windscreen has a green-tinted strip at the upper edge to provide additional protection against glare.

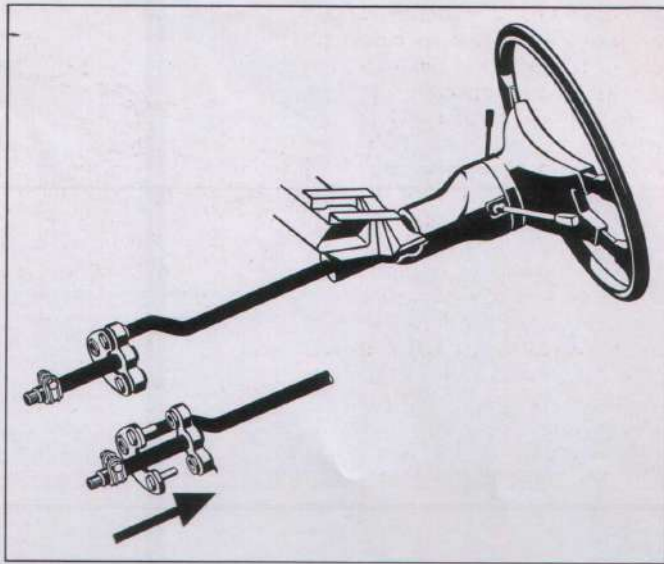

*The Audi Coupé's safety steering column with flexible mesh element.*







# The Coupé that makes peace with back seat drivers.

At last you can drive a coupé without sacrificing your creature comforts.

For within its streamlined aerodynamic shape, the Audi Coupé offers a surprising amount of interior space, with the kind of dimensions some saloons would envy.

Believe it or not, there is room for 3 full-size adults in the back.

Nor do we stint those in the front. The sophisticated design of

the bucket seats provides excellent lateral support and ample room to stretch out. The driver's seat is also adjustable for height. Which means that everyone can find his or her own optimum driving position.

And there's more to boot. In addition to the interior room, the Audi Coupé has plenty of space for luggage, with a capacity of 15.6 cu.ft. The boot is also fully lined and illuminated, so you can

find your way around in the dark.

Even the Coupé's fuel tank is bigger than most, holding nearly 15 gallons, so you can drive for almost 500 miles on a single tankful.

**More surprises.** As an aid to thrifty motoring, there is an indicator that lights up whenever a change to a higher gear would bring the engine to a more efficient, and economical, speed range.

This is one part of the well-designed instrument panel, which provides all important information at a glance. Including speed, time of day, engine speed, fuel reserves, oil pressure, oil temperature and voltage.

The switches for the lights, heated rear window, and indicators are within easy reach. The two-speed windscreen wipers come with intermittent operation and wash/wipe settings. And



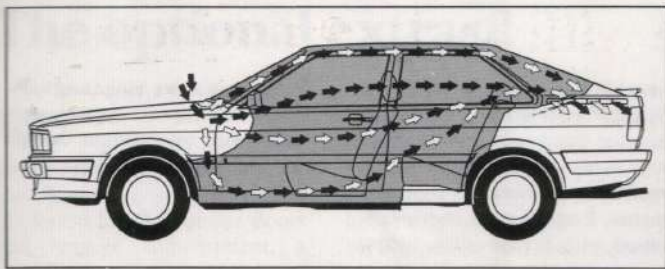

The directional flow of the quick-acting, adjustable heating and ventilation system.

there's a rear wiper with wash/wipe settings as well.

For your greater comfort, as well as safety, we've added a few more touches. The Coupé has no

fewer than 30 sources of light, so you can see – and be seen – at night.

The sophisticated heating and ventilation system provides fresh

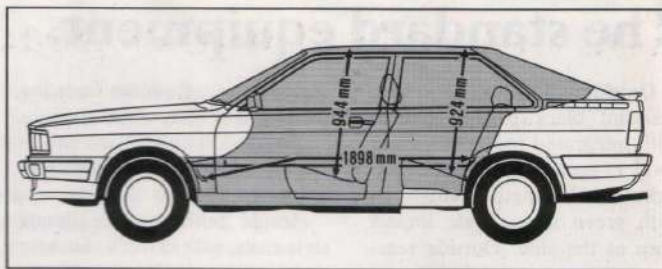

air and the required temperature to ensure total comfort whatever the season.

And finally, the interior colours are carefully matched and

non-distracting, to help put you at ease, and keep you that way, however long your ride.

All in all, the Audi Coupé is an ideal long-distance car.

Car radio at extra charge.



# The standard equipment.

**Outside:** Bumper bars with resistant black plastic coating, with integrated indicators, front spoiler, rectangular twin headlights, and laminated windscreen with green strip. Wide impact strip at the side. Outside rear-

view mirror, adjustable from the inside. Light alloy wheel rims.

On the 130 bhp version only – steel sunshine roof and front foglights.

Inside both models: Sports style seats, with driver's seat ad-

justable for height. Tweed fabric. Seat belts for all five seats. Adjustable head restraints in front and two moulded head-rests at rear. Several storage compartments. Easy to read instrumentation with rev.-counter, quartz

clock, oil pressure gauge and voltmeter. Two-speed windscreen wipers with intermittent operation and automatic wash/wipe settings.



*Clearly arranged instrument dials.*



*Halogen headlights with twin-jet washers.*



*Alloy wheels.*



*Fabric lining on doors.*



*Five-speed gearbox.*

# The optional extras.

We have only a few options to offer you on the Audi Coupé. All the major luxury equipment is incorporated in the original specification.

Central locking for the doors and luggage compartment, a

wash-wipe system for the rear window, electric windows, a head lamp washing system and power steering are all standard fitments.

A sunroof, integrated front fog lamps are standard on the 130 bhp version and are offered as optional

equipment on the 2 litre model. Automatic transmission is available on the 2 litre version only. And you can now order an optional computer to keep an even closer eye on your driving, journey times and fuel consumption.



Rear window wash/wipe system (standard).



Central locking facility (standard).



Automatic transmission (optional on the GT).



Stereo radio/cassette system.

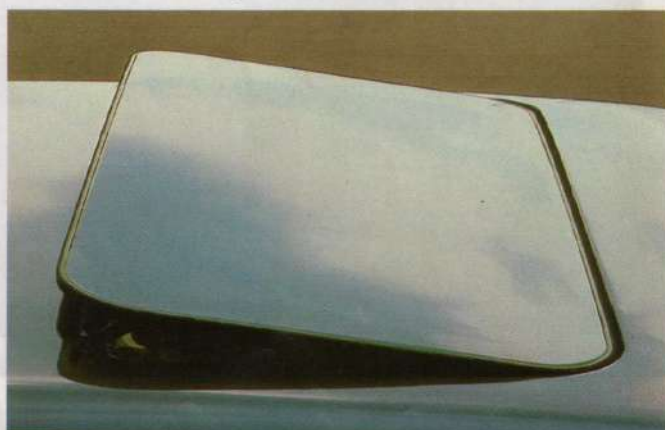

Steel sunshine roof (standard on the 130 bhp version optional on the 2 litre model).

# In addition to the many advantages of the Audi Coupé there are the advantages offered by a major manufacturer: a comprehensive warranty and an extensive dealer network offering a wide range of services.

**The advanced 1 year warranty. Unlimited mileage.** A manufacturer who gives this kind of warranty must be absolutely convinced of the quality of his cars. However, with this warranty we believe we give you more than just proof of quality. We give you the assurance that you made the right choice. The 1 year warranty has worldwide validity.

**6 year warranty.** Audi bodywork carries a 6 year warranty against major corrosion and rust. New vehicles subject to this warranty must be cared for in accordance with the operating instructions. Bodywork must be inspected at prescribed intervals by an authorised Audi dealer. Full details of this warranty system are

available from your Audi dealer.

**3 year paintwork warranty.** This new introduction, which is unmatched by any other major manufacturer, really provides you with the widest possible cover on any new car.

There are no special conditions attached and paintwork defects will be rectified under guarantee provided these are not caused by owner neglect or lack of care.

**A wide service network.** There is a wide network of Audi service stations around the world. The Audi service includes the latest in high efficiency equipment and special tools to provide maintenance and service for your car throughout its long life.

All this guarantees a long life

and high resale value for your Audi.

**Trained personnel.** The personnel of the Audi companies, service managers, engineers, reception engineers, etc., receive regular training in factory-approved schools. At the factory there is a special department which carries out research into new servicing techniques in co-operation with Audi dealers. All this results in quicker, better quality service and lower maintenance costs.

**Spare parts and exchange units.** The Audi service includes a well-organized Parts Service. Guaranteed, high-standard exchange units are available from all Audi dealers. Genuine ex-

change units undergo stringent inspection at the factory.

**Financing, insurance, leasing.** The Audi service may include financing, insurance and leasing for your car. Your Audi dealer will be pleased to give you information on the availability of these services.

**Personal Export.** The Audi service also includes the Personal Export facility which arranges for Overseas, Military and Diplomatic sales of Audi vehicles.

For information on this service the Personal Export Centre, 95 Baker St. London, W1, should be contacted. (Tel. 01 486 8411)

Technology in a class of its own.

