



# A8

Audi A8 | A8 L | A8 L W12

Vorsprung durch Technik **Audi** 



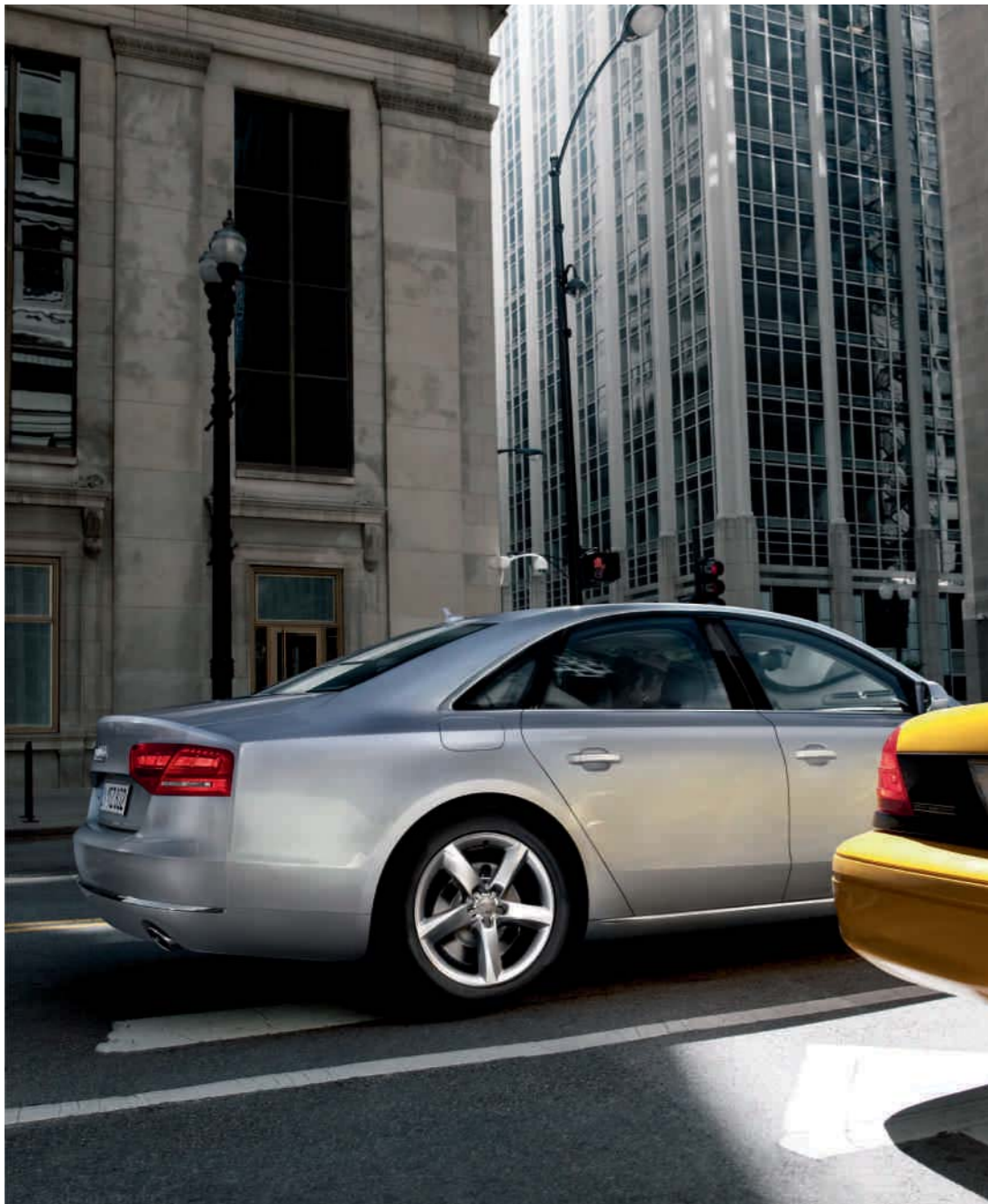

	Page		Page
<b>Fascination</b>			
	6	The Audi A8 experience	34
	26	The Audi A8 L experience	
<b>Technology</b>			
	42	Audi Space Frame (ASF)	56
	44	FSI®/ TFSI®	58
	46	TDI	60
	48	MMI® – Multi Media Interface	62
	50	Audi drive select	64
	52	Suspension	66
	54	quattro®/quattro® with sport differential	
<b>Equipment</b>			
	68	Audi exclusive	92
	74	Audi design selection	94
	78	Paint finishes	96
	80	Seats/seat covers	102
	87	Headlining	105
	88	Inlays	106
	90	Wheels/tyres	107
			92
			94
			96
			102
			105
			106
			107
<b>Other</b>			
	108	Audi Service	114
	109	Audi Genuine Accessories	116
	112	Technical data	118
			114
			116
			118

The equipment for the vehicles illustrated can be found on page 123. The fuel consumption and CO<sub>2</sub> emission figures can be found from page 112 onwards.

For over 100 years, we have been perfecting the art of being ahead. Here is our masterpiece.

We have been working towards it. Hours, days, months, years. We have discarded what was already good to replace it with something even better. We questioned what was already established to introduce something innovative. And we considered every detail in order to ensure the highest standard of quality in design, comfort and technology. The result is the Audi A8. It represents the very latest in Vorsprung durch Technik. An invitation to you to try out the art of being ahead.





---

## The art of progress.

A dynamic appearance. Innovative engines. Unmatched comfort.  
A unique vehicle in search of unique drivers.

# A8



A clear line from beginning to end.  
Like with everything we do.

The Audi A8 experience: Dynamic flowing lines define the impressive vehicle. Generously proportioned surfaces and a distinctive shoulder line make the side view both masculine and sporty. The three-dimensional Audi Singleframe, together with the elegant headlights, forms an unmistakable face.



Enjoy the unique sight: The dynamic line, commencing at the front wheel arches, rises towards the rear of the vehicle, creating visual forward thrust on the Audi A8. Below, the lively interplay of light and shade creates the side of the Audi A8. The broad shoulder gives an appearance similar to that of a coupé. Generously sized aluminium wheels convey prestige and make a lasting impression.





A space whose generous proportions welcome you. Materials that convey high standards and quality. Technology that assists the driver. You will feel immediately at home inside the new Audi A8. The quality of manufacturing which can be experienced through the carefully hand-crafted leather and wood, is palpable down to the last detail. The all-new selector lever is shaped like a yacht's control lever. It is not only used to change gear but also serves as an ergonomic hand rest when operating the MMI®. Enjoy the exquisite pleasure of being on the road in an Audi A8.



There are many types of luxury.  
This is ours.



As soon as you open the vehicle door, the interior shines out at you. The optional ambient lighting can be adjusted individually, ensuring your Audi A8 gives you your own personal welcome. The ambient lighting, with its choice of three colour moods – Polar, Ivory or Ruby/Polar – can also create specific lighting effects in the interior and make the already generously spacious interior appear even more capacious. Central controls are accentuated, making it even easier to operate them; illuminated surfaces create a visual impression of more space, whilst the centre console even appears to float. Additional reading lights in LED technology available by request in the rear.



The comfort sports seats, available on request, have numerous electric adjustment options and can be adapted to suit the individual requirements of driver and front passenger. The pneumatic side bolster adjustment and lumbar support improve stability and increase comfort. The comfort sports seats in Valcona leather can be optionally fitted with seat ventilation and a program with five different types of massage each in 5 levels of intensity for the front seats.





The highest standards right down to the smallest detail – a demonstration of prestige and status. The three-dimensional Singleframe impresses with chrome struts in a progressive design: The bevelled corners form an elegant unity with the engine bonnet.





**Power raised. Fuel reduced.  
Vorsprung extended.**

An imposing appearance requires a dynamic drive system. Here the high-torque FSI<sup>®</sup>-, TFSI<sup>®</sup>- or TDI engines use their fuel with particular efficiency. Thus the engines\* in the Audi A8 convert power to driving pleasure.

\*The fuel consumption and CO<sub>2</sub> emission figures can be found from page 112 onwards.





---

## The art of travelling with consciousness.

The Audi A8 L offers even more luxury space to meet your standards. It makes it really easy for you to enjoy driving, to relax or to work in peace and quiet.

# A8

Audi A8 L

---

A powerful, sovereign appearance: The Audi A8 L is 13 centimetres longer than the Audi A8, which means more leg room and relaxation for you.





---

## Travel comfortably, work intensively, relax consciously.

The large rear doors enable the occupants to enter the vehicle easily – and you can buckle up comfortably. Electrically adjustable rear individual seats are available on request and boast a range of comfort functions, enabling you to create an individual seat position that conforms to your requirements. The long, leather trimmed centre console creates a spatial division, giving you all the more feeling that you have found a place just for you. The optionally available panoramic glass roof floods the interior with sunlight.

The details on Audi design selection are presented from page 74 onwards.



And if you prefer to relax through entertainment: The optional Rear Seat Entertainment has two 10.2 inch LCD displays on the backs of the front seats, upon which various kinds of media can be played.





The art of sensing  
power in silence.

Our masterpiece in comfort, dynamics and exclusivity: the Audi A8 L W12 fascinates with its imposing style and the superior performance of its twelve-cylinder engine.

The fuel consumption and CO<sub>2</sub> emission figures can be found on page 113.

# A8

Audi A8 L W12

Concentration  
on what is essential:

12 cylinders, 368 kW, 625 Nm.

Enjoy every moment of the exceptionally quiet operation of the twelve cylinder – and experience its powerful acceleration: Your Audi A8 L W12 accelerates from 0 to 100 km/h in just 4.7 seconds. Whether you experience your drive as more agile or comfortable, depends entirely on you.

The fuel consumption and CO<sub>2</sub> emission figures can be found on page 113.



Presence, strength, composure. The mark of real character. Dynamic lines define the sculptured vehicle body, the innovative LED headlights set a striking accent. The Audi Singleframe with its high gloss black painted grille structure will impress you with its horizontal chrome struts and is branded with a W12 emblem. The 15 spoke wheels and the newly designed air intakes with chrome inserts accentuate the exclusivity of the Audi A8 L W12. Two trapezoidal tail pipes are harmoniously integrated into the bumper and they round off the impressive rear design.





A special feature: the relaxation seat in the rear, available on request, offers you a unique and luxurious atmosphere. The electrically adjustable seat with massage function and an electrically extending footrest in the passenger seat backrest provide deep relaxation. And the four programmes of the massage function are easy to select via remote control. An illuminated sill trim with exclusive W12 emblem welcomes you to the interior of the Audi A8 L W12.



**Cast aluminium components:** Structural castings provide a high degree of design freedom and function integration. Variable wall thicknesses, flexible shaping and ribbing optimised for the flow of forces ensure that material is only used where it is actually needed. The development of high-strength structural castings establishes the basis for superb integration of extruded aluminium sections into the ASF structure.

**Extruded aluminium sections:** Thanks to variable wall thicknesses, profiled cross sections and the use of high-strength alloys, extruded profiles enable an extremely rigid vehicle body to be achieved. They also facilitate excellent energy absorption in the deformation zones. They reveal their full potential in the optimum integration of the castings to form part of the structure, thereby ensuring the high performance of the ASF structure.

**Aluminium panels** supplement the structure formed by the castings and the profiles. They increase overall body rigidity with transition points optimised for force flow, simultaneously combined with superb individual part performance. Thanks to new, thermally-hardened alloys, they unite maximum function with low weight. The correct choice of joining technology also plays a key role here. Only if this is right will the individual parts be integrated into the ASF to form part of the structure and thereby perform a load-bearing function.

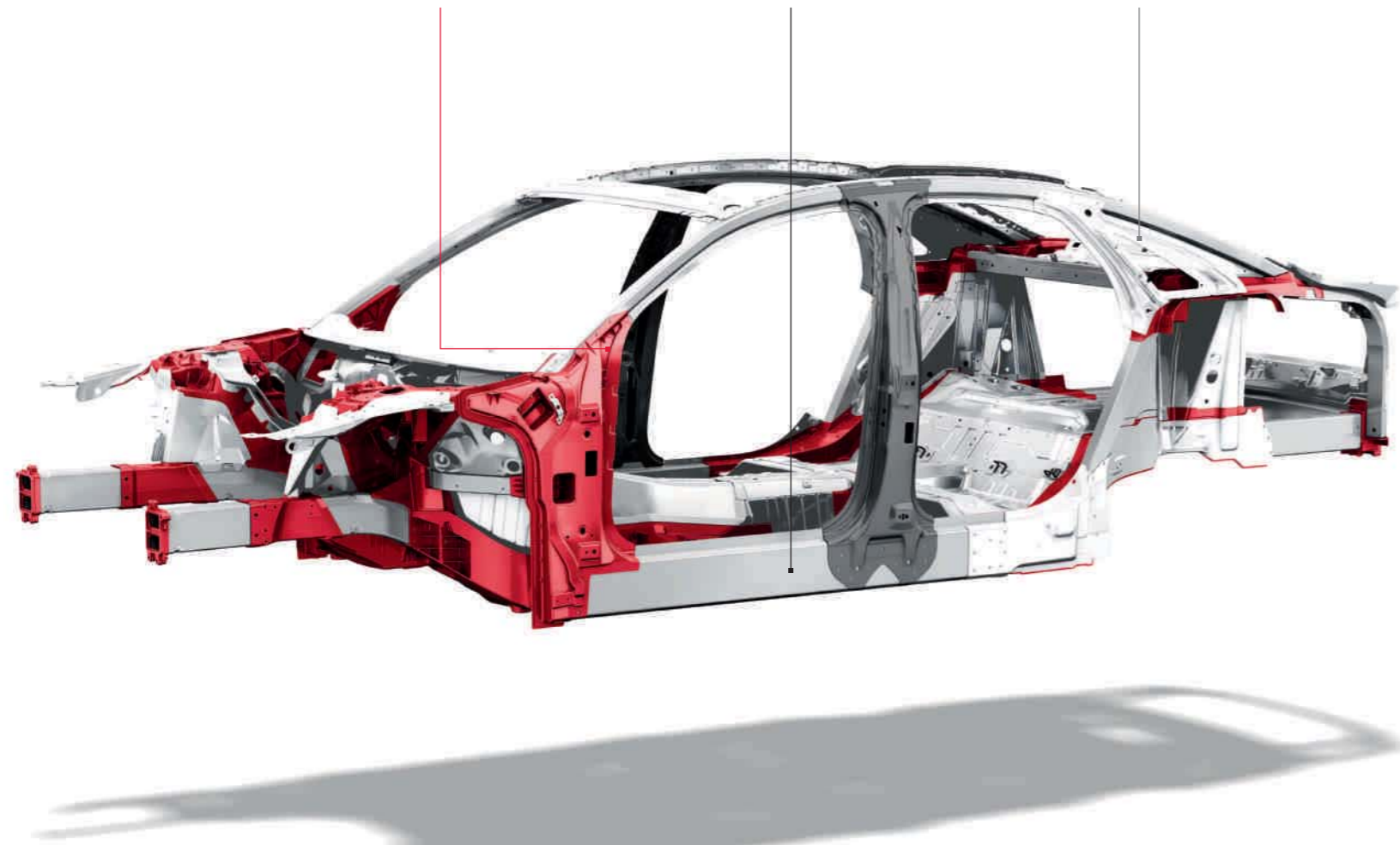

## Why have an aluminium body?

Because lightweight construction offers heavyweight advantages.

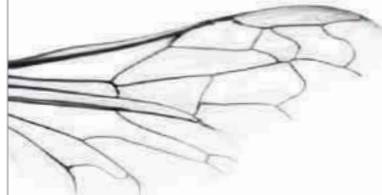
Subject: Efficiency	 <p><b>Nature as benchmark: the bionic principle of lightweight construction.</b> A great deal of inspiration from nature is evident in the development of the Audi Space Frame (ASF). The sophisticated ribbing of the large cast components illustrate most clearly the influence of bionics: The body structure is amazingly similar to that of an insect wing, which can move a great weight in relation to its own very low one. The Audi Space Frame (ASF) unites the advantages of weight reduction and body rigidity in just this way. The result: the most technically refined ASF yet.</p>
---------------------	---

The aluminium in the Audi Space Frame (ASF) is lightweight, offers greater freedom of design than steel and the components made from it are noted for their high rigidity. For you, the ASF construction means, in specific terms, increased safety, reduced fuel consumption, sporty handling and reliable quality through the use of selected materials.

A revised Audi Space Frame (ASF) is used in the current, third generation of the Audi A8. The goal

of the body development was to consistently implement and enhance the sporty, progressive and high quality character of the A8. A homogeneous vehicle front-end provides improved protection not only for the car's occupants but for other road users as well.

In addition, new, high-strength aluminium alloys are used for panels, castings and profiles and further reduce weight. For the first time, hot-formed steel panels are also integrated into the

body structure in order to further improve its function. They are located in the region of the B-pillar.

You can feel these innovations distinctly: As well as sporty and comfortable driving characteristics, the new Audi Space Frame (ASF) offers a high level of safety and durability as well as maintaining value.

The FSI®-/TFSI® principle:

# Where others stop, we are just beginning.

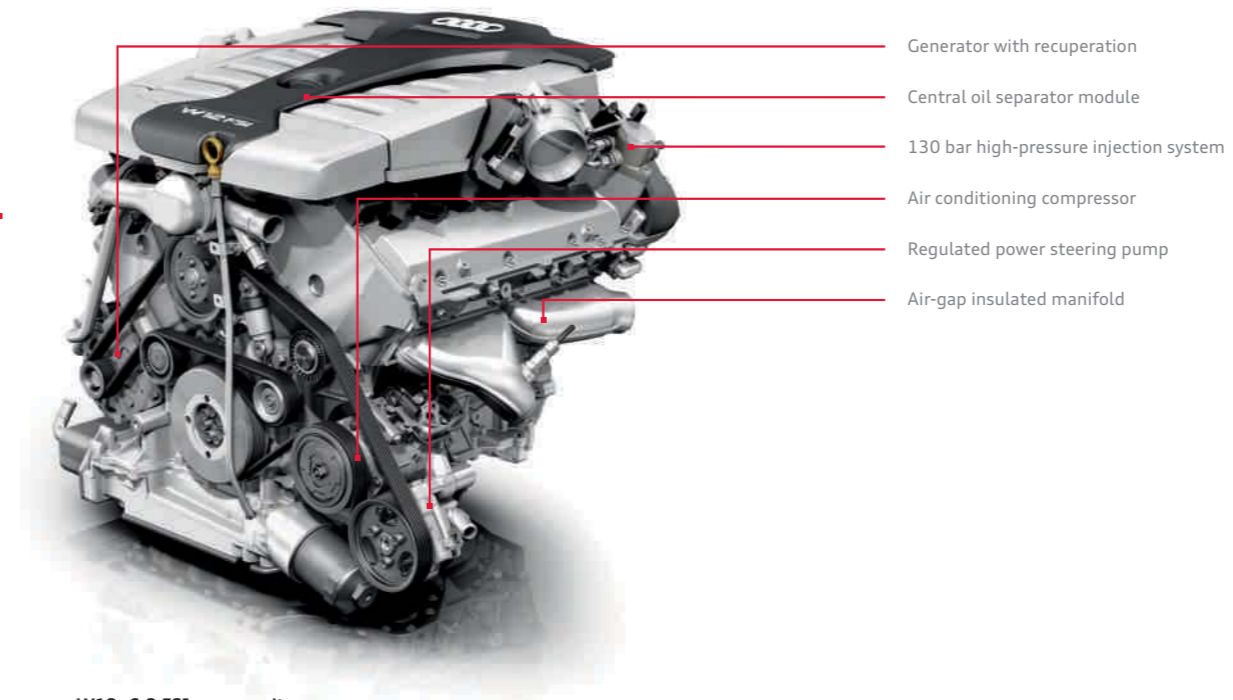
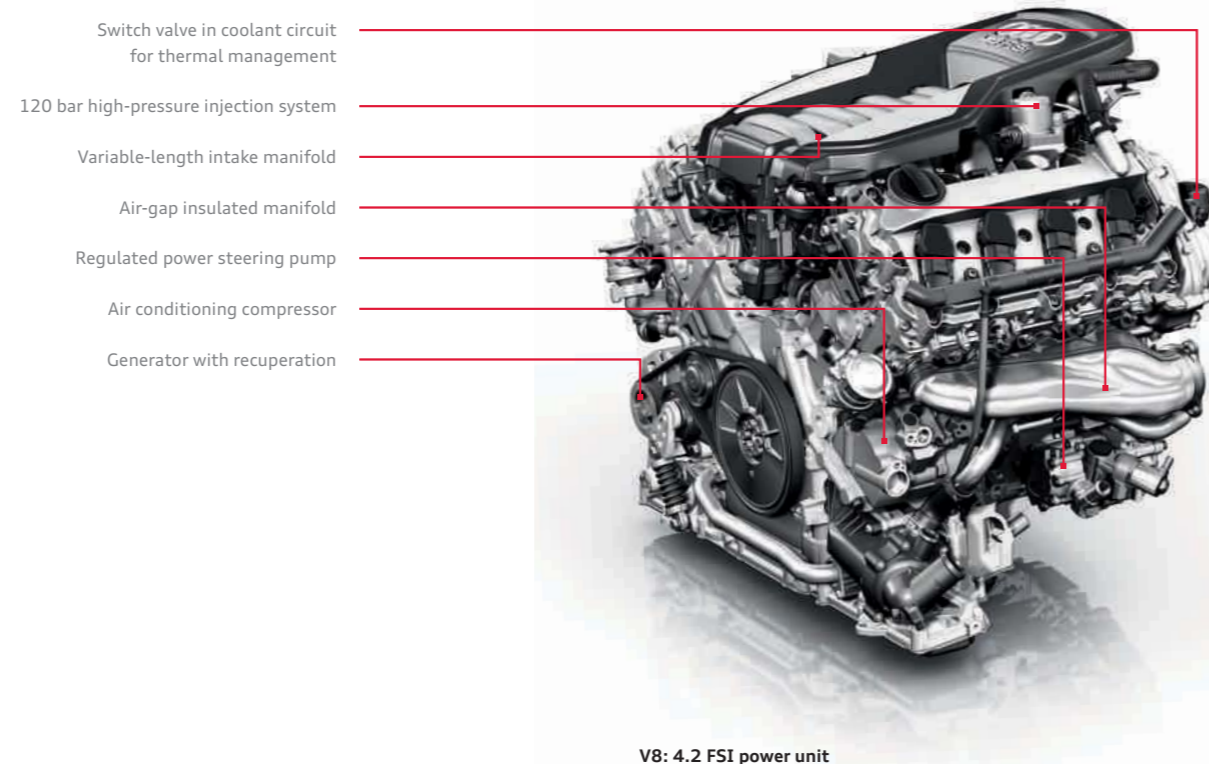

**The engine management system** calculates the injection quantity and ignition timing according to how much power the driver wants. In normal operation, the injection pressure is between 30 and 120 bar, in the A8 L W12 up to 130 bar. All power units in the A8 feature, for the first time, multi-hole high-pressure injectors that ensure optimum preparation of the fuel in the cylinder.

Who says that you can only think about fuel in terms of litres? Our engineers wanted to put every drop of petrol to optimum use. From this emerged FSI®.

In FSI technology, the fuel is injected directly into the combustion chamber and atomised into a fine spray. This way, the fuel – metered to almost droplet precision – can be called upon the millisecond that the engine requires it. This means better utilisation of the fuel and ultimately, reduced consumption. Legendary 24 hour race of Le Mans has shown how important an efficient use of fuel is: There, the Audi R8, powered by an FSI engine, has been able to enjoy several convincing victories.

The petrol engines in the Audi A8 utilise FSI technology, too. The latest generation of engine control units and an innovative thermal management system also help to reduce fuel consumption. The engine thus reaches its operating temperature more quickly after a cold start, thereby reducing friction losses. A recuperation system reclaims energy when the vehicle slows down, as you can observe when you accelerate. In addition, all engines comply of course with the EU5 emission standard.

The Audi A8 4.2 FSI offers an impressive output of 273 kW – and this with combined fuel consumption of 9.5 l at 100 km/h. Its maximum torque of 445 Nm takes you from 0 to 100 km/h in just

5.7 seconds. The strongest engine, the 6.3 litre W12 engine with 368 kW generates a maximum torque of 625 Nm, which accelerates the car with agility to up to 250 km/h – here the speed reaches 100 in just 4.7 seconds. It is remarkable for its running smoothness. This is achieved mainly through the outstanding balance of free inertia forces. In addition, the large number of cylinder accounts for very smooth running, due to the fact that the higher the number of cylinders is, the lower is the “firing interval” of the engine. This way the ignitions take place in shorter intervals, which has a positive effect on the running smoothness of the engine.

TFSI® technology is used in the Audi A8 3.0 TFSI quattro. What’s special about that is: it combines the advantages of FSI with a supercharging that ensures even better power delivery. The six-cylinder engine generates a powerful 213 kW. An innovative mechanical supercharging system with charge air cooler is employed, and turns the 3.0 TFSI V6 into a compact powerhouse – with moderate fuel consumption. The peak torque of 420 Nm is sure to impress you, as will the torque curve. Thanks to its very spontaneous responsiveness and exceptional power delivery across the entire speed range, the six-cylinder engine promotes a particularly dynamic driving style. The Audi A8 accelerates to 100 km/h in 6.1 seconds and still has plenty of power reserves left after that.

The fuel consumption and CO<sub>2</sub> emission figures can be found from page 112 onwards.

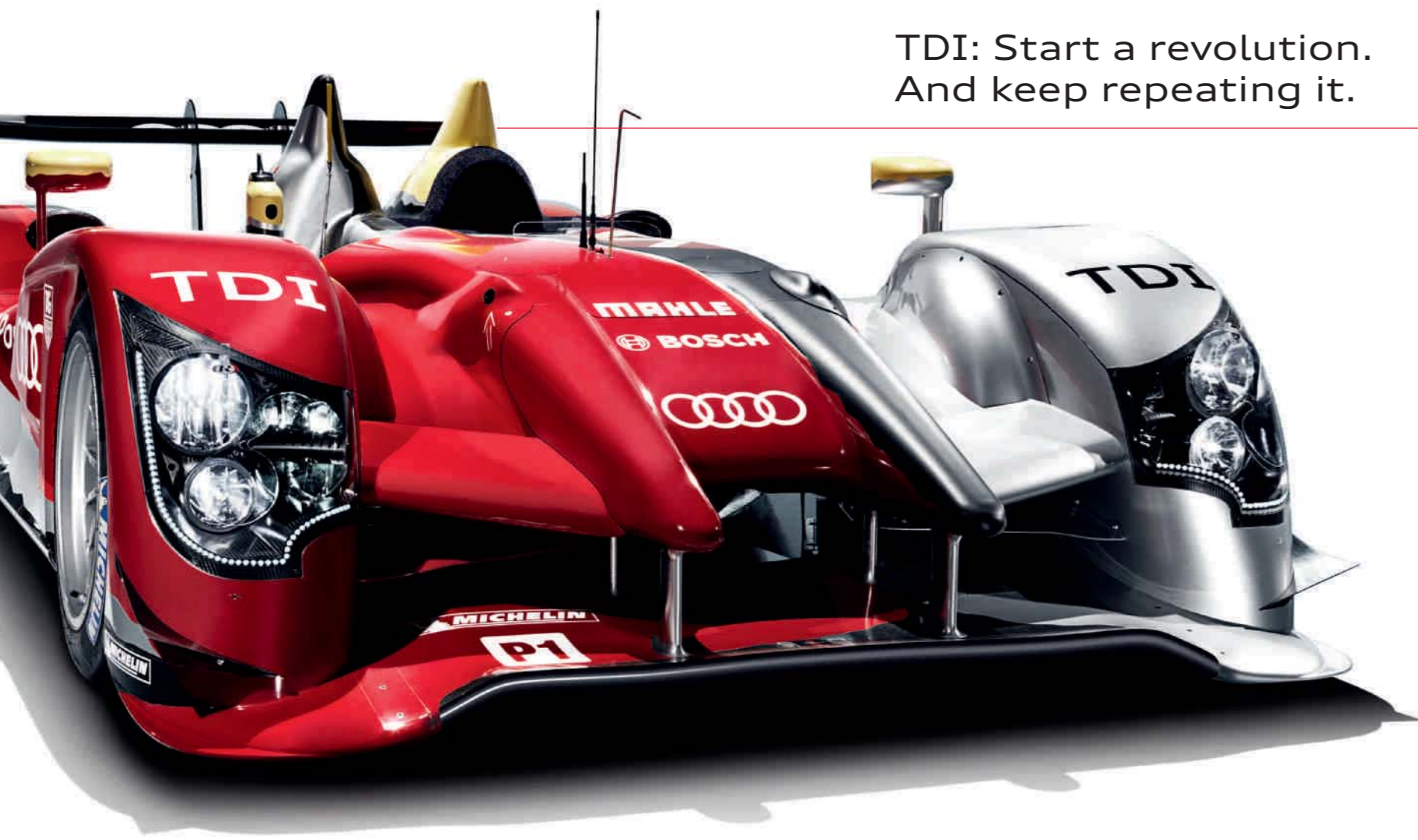

TDI: Start a revolution.  
And keep repeating it.

A diesel on the podium: the R15 TDI

Regulated power steering pump  
2,000 bar high-pressure injection system  
Air conditioning compressor  
Turbocharger with rpm recording and regulation  
Switchable water pump (thermal management)  
Generator with recuperation

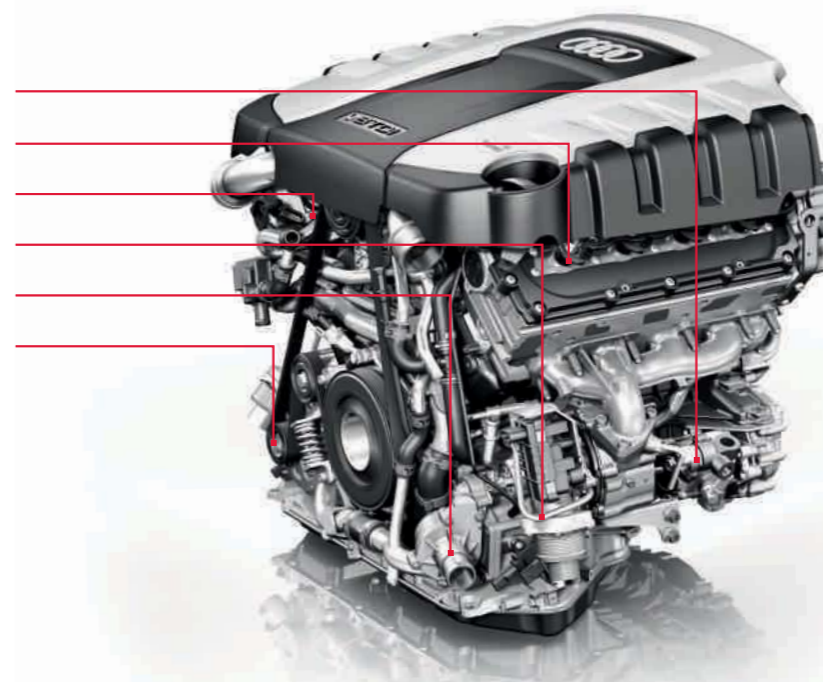

4.2 TDI power unit

One in every two Audi cars sold today is a diesel. What sounds perfectly normal now was cause for huge excitement 20 years ago, when Audi revolutionised the market with the first 2.5 litre TDI engine. Since then, developments such as common rail technology have made TDI even more efficient. Piezo injectors ensure the fuel is finely and precisely distributed. Consequently, since the first TDI, the engines have become more economical, whilst specific out-put has increased. So it was only logical that a diesel car should then enter the world of motor-sport. And successfully too.

In 2006, the Audi R10 TDI won the 24 h race at Le Mans – the first diesel powered racing car to do so. It was able to repeat this victory on several occasions.

Engines\* with winner's genes await you in the Audi A8. For example, the 3.0 TDI power unit with 184 kW, which of course works with the intelligent Common Rail technology. Of course, efficiency does not exclude driving enjoyment: With the powerful 550 Nm of torque, you can accelerate your A8 from 0 to 100 km in just 6.1 seconds.

\*The fuel consumption and CO<sub>2</sub> emission figures can be found from page 112 onwards.

The piezo injectors open and close within milliseconds and inject fuel several times into the combustion chamber at pressures of up to 2,000 bar. In some cases, an injection process can involve the injection of the tiniest of amounts weighing less than a thousandth of a gram.



Pre-injection results in a "gentle" combustion process and consequently excellent combustion acoustics and agreeable engine running characteristics.



Even more powerful is the 4.2 TDI\*: 258 kW and a maximum torque of 800 Nm will take you from 0 to 100 km/h in just 5.5 seconds. Fuel consumption, however, is just 7.6 litres per 100 km. This is also assured by the common rail technology which injects the fuel directly into the combustion chamber at pressures of up to 2,000 bar. An innovative thermal management system is at work in the 4.2 TDI engine too where it helps to reduce fuel consumption by heating up the coolant quickly. In addition, it has been possible to reduce the weight of the engine despite its greater engineering complexity.



**Menu:** Display of the 7 available submenus which can also be alternatively selected using the hard keys.



**Information:** Display of current traffic information, access to online services such as navigating using Google Earth images and WiFi hotspot for Internet access (if Bluetooth car phone online is also ordered).



**Phone:** The optionally available mobile phone fitting (Bluetooth) and Bluetooth car phone online have a selection screen containing call lists, directory and selection interface as the start-up setting.

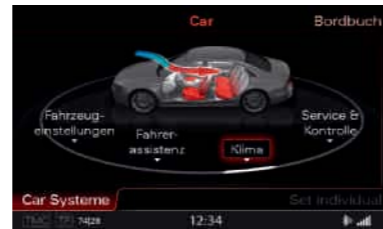

**Car:** This function allows the direct control of driver assistance systems, vehicle settings, climate control, auxiliary heating and service.

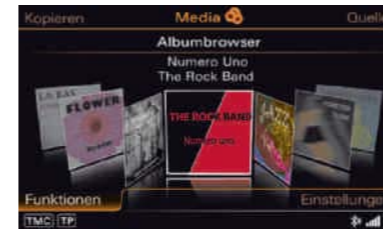

**Radio:** The integral radio receiver is set up for VHF, LW and MW and optionally transmits digital radio with a continually updated station list.



**MMI® touch:** You can “write” on the MMI touch using your finger. The system recognises letters and numbers. Compatible with navigation and telephone; additionally you can thumb through the albums of your music collection in the jukebox with a brief stroke of the finger.



**Navigation system:** The hard disc navigation system MMI navigation plus with MMI touch provides a 3D map view and a 3-dimensional display of famous buildings and places of interest.



**Media:** Display of available media sources such as the jukebox, inserted SDHC cards, Audi music interface or CDs and DVDs; display of optional TV tuner



## Follow your intuition – it will get you to the right destination.

Our promise of “Vorsprung durch Technik” is one that we keep in every area of an Audi – as demonstrated by the Multi Media Interface (MMI®), which has undergone further development. The MMI is used to operate a multitude in-car media, the navigation system and other comfort functions. Until now, it has been easy to use the MMI – now it is even easier. Fewer but-

tons provide a better overview. The operating buttons for radio and media are logically located with the volume control. The other six hard keys, for telephone or navigation functions for example, are located around the central rotary/push-button control – for intuitive operation. Also new: is the carousel layout in the MMI display. This provides you with an even better

overview, making it even easier for you to get to your destination. The MMI navigation plus has a special feature: the unique MMI touch. It is located to the left of the central control panel and is within comfortable reach, particularly in combination with the new selector lever. MMI touch offers you among other things a new and intelligent way of controlling the navigation

functions – by “writing” letters or numbers on the touch-sensitive screen with your finger. The system acknowledges the entry after each character acoustically. With MMI touch you can also thumb through the albums of your music collection in the jukebox with a brief stroke of the finger.



# Why does the Audi A8 suit you so well? Because it adapts itself to you so well.

## Audi drive select.

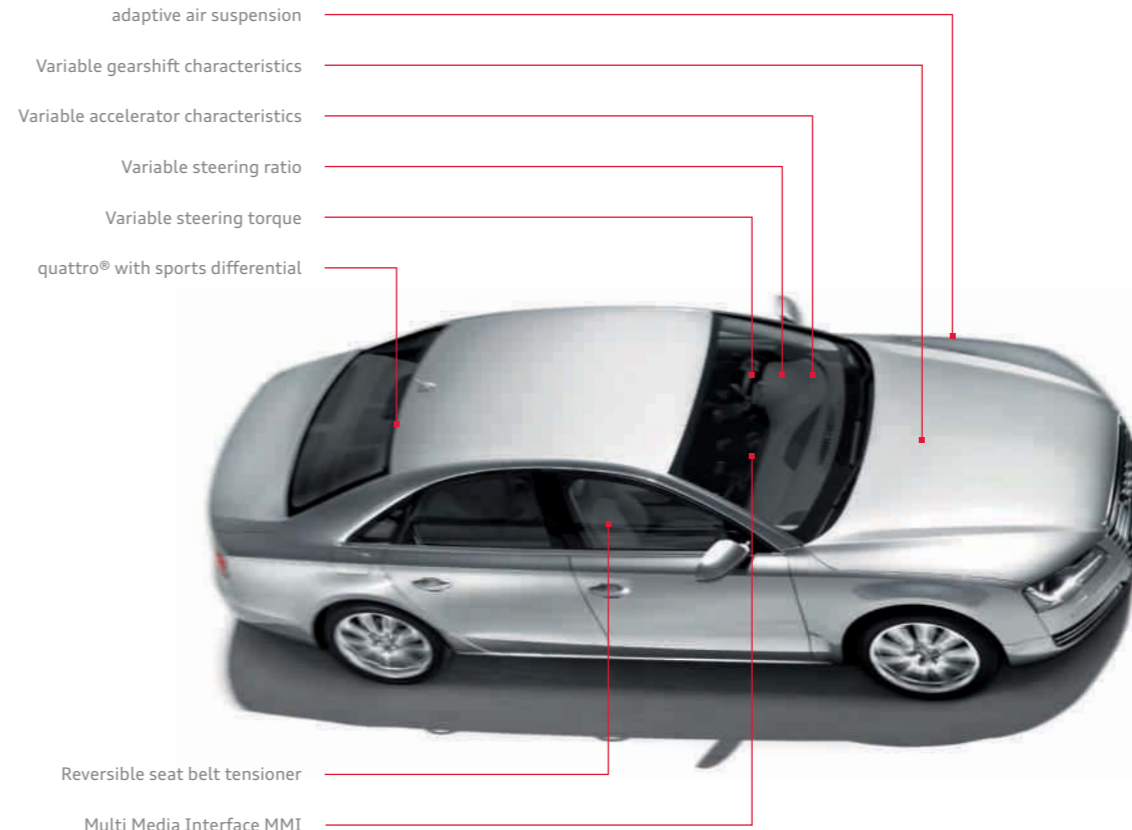
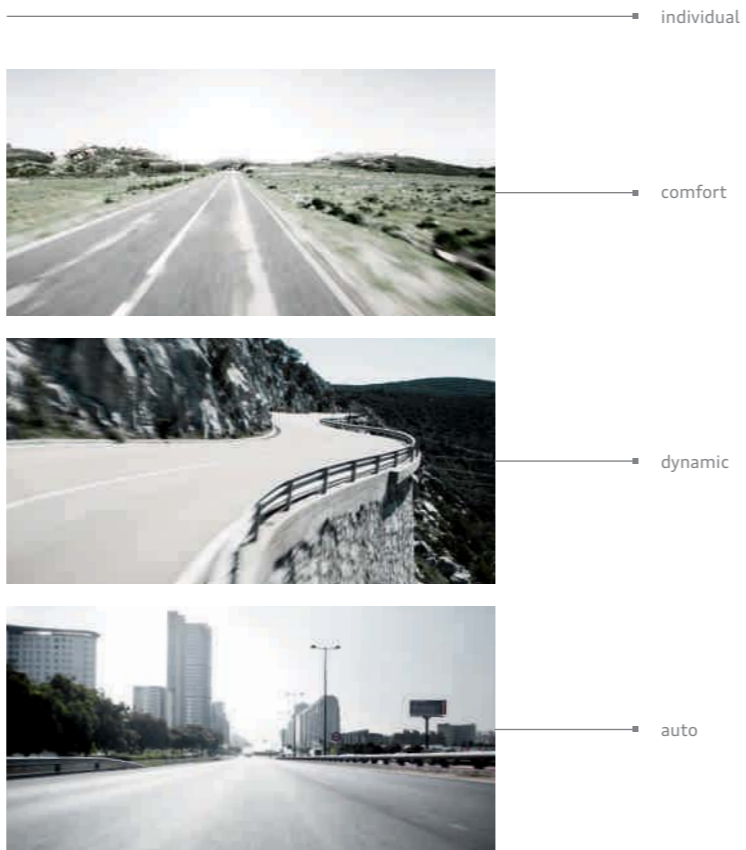

Everybody defines driving dynamics differently. That is why we give you the opportunity to adapt the car to your desires. With the standard Audi drive select, you can influence individual vehicle components at the push of a button and so change the character of your Audi. Audi drive select makes it possible.

Four modes are available to you: comfort, dynamic, auto and individual, the latter mode allowing you to determine yourself how the

associated vehicle components should behave. The comfort mode is especially suitable for providing the most relaxed driving possible on long journeys. For an enhanced sporty drive, for example on winding roads, the dynamic mode is ideal. Auto provides the balance between an agile and comfortable driving style.

Audi drive select works like this: The system changes, amongst other things, the accelerator characteristics, the adaptive air suspension, the

gearshift characteristics, the damper regulation, the reversible seat belt tensioner (part of Audi sense basic) and, if fitted, the sports differential and dynamic steering. The latter provides even more precise steering with immediate feedback from the road. With Audi drive select, the steering ratio curve varies depending on the speed. That means in dynamic mode the steering responds more directly than, for example, in comfort mode. Audi drive select can change even more driving components: In the transmission,

the engine speeds at which the gear changes take place are adjusted – in dynamic mode, gear change occurs at higher engine speeds and in comfort mode at lower ones. Damper regulation sees a change in the level of damping forces, whilst with the optional quattro® with sports differential (standard on the 4.2 TDI), the distributed drive torque is varied.

Subject: Dynamic steering  
The harmonic drive gear system

**With dynamic steering,** Audi's engineers have solved a problem that has kept many vehicle manufacturers busy: how to develop a steering system where the steering ratio and steering force are automatically adjusted to the driving speed. In the search for a gear system that reacts to the current vehicle status, the Audi engineers came across a system that was originally developed for NASA: the harmonic drive, characterised by an elastic transfer element. It was used for the first time in 1971 for the Lunar Rover reconnaissance vehicle during the 4th moon landing, and in the Mars Sojourner that explored the red planet in 1997. It is currently being used in the Mars Spirit vehicle. Audi uses the harmonic drive gear system for its dynamic steering where it ensures excellent and dynamic steering feel, irrespective of the speed. For this steering system, Audi was awarded the inaugural "Award for Mechatronic Innovation" by the VDI (The Association of German Engineers) in 2009.





**Fully load-bearing air springs** on the front and rear axles of the vehicle work together with the infinitely variable electronic damper system to provide a sporty and comfortable driving feel.

**The infinitely variable damping** adjusts itself automatically to every driving situation in fractions of a second. Even with asymmetrically distributed loads, the vehicle remains in a level position thanks to continuous ride-height regulation. Drivers can determine how dynamically they want to travel and what character their Audi should adopt. Different modes are available to the driver and can be selected using the Audi drive select system.

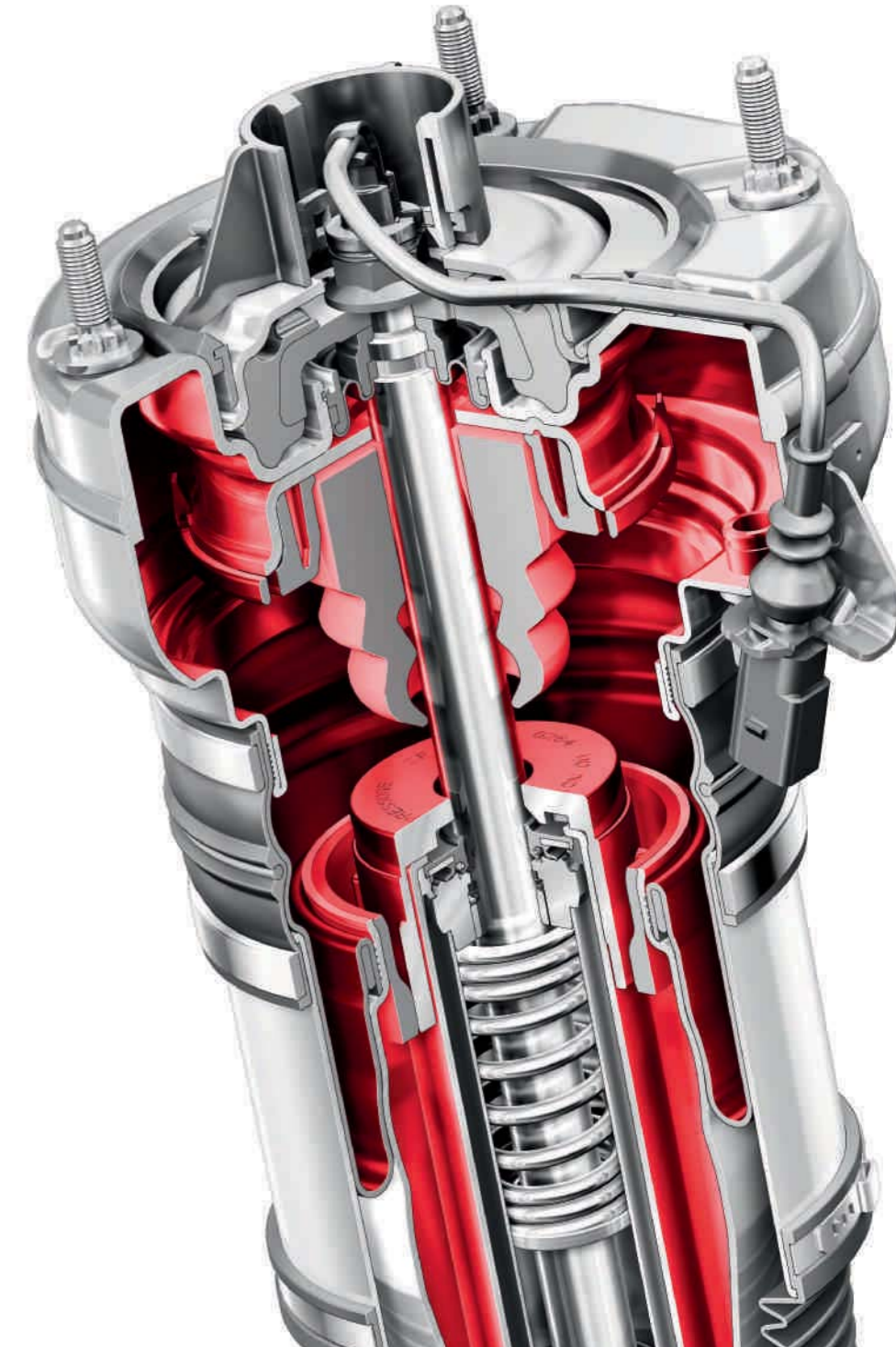

# Dynamics and comfort were once opposites. We've made the differences vanish into thin air.

Each road is different. So it's good when, despite that, you notice no difference in comfort. How does that work? In the Audi A8, the chassis adapts to the driving situation and to the road surface as standard. We call it adaptive air suspension. An electronically controlled air suspension system operates individually on each of the four wheels and is combined with an infinitely

variable adaptive damping system. Sensors on the body and on the axles continually monitor the current driving situation and send information to the system during the journey. Furthermore, the air springs guarantee that, even when carrying heavy loads, the vehicle's driving characteristics will not be impaired. The advantages of the adaptive air suspension can be felt after just a few

metres. And then most certainly when you drive round a corner or bend. The rolling or pitching motions of the body are substantially reduced, the vibration behaviour and the spring travel remain optimal. In future, you may still be able to see uneven roads, but you'll seldom feel them.

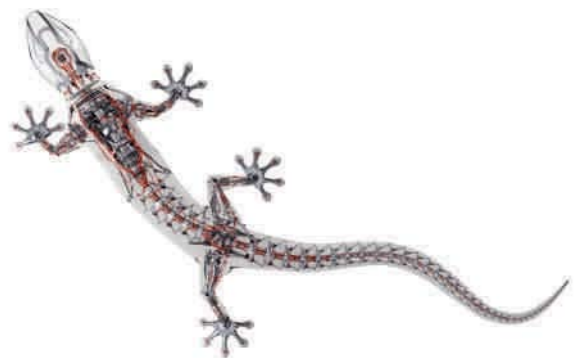

With quattro®<sup>®</sup>, we have invented one of the best all-wheel drive systems in the world.

Of course, that was not enough for us.

quattro® is a permanent all-wheel drive system. If the wheels on one axle of the vehicle lose grip on the road and threaten to spin, then the power is transferred to the other axle – automatically and permanently distributed through the centre differential. The basic distribution is 40 : 60 – 40 % of the power comes from the front, 60% from the rear axle. The advantage: better traction during acceleration and improved safety due to exceptional grip. So much for the technology. But what makes quattro unique is really the driving feel. “As if you are stuck to the road,” some customers say. We put it like this: quattro gives you a better feel for the road – and with more safety.

The optional quattro® with sports differential further reinforces this unmistakable quattro feeling. Vehicles tend to experience understeer when steering or driving into corners. This is a normal physical process: A moving object opposes a change in direction. The elastic tyres and the suspension mounts tense up until the new direction has been adopted. When accelerating into a corner, the load on the front axle is reduced and it therefore transfers less lateral force to the tyres – the vehicle understeers.

With the sports differential on the rear axle, this tendency has been significantly counteracted. That’s because the quattro rear axle differential

has been extended left and right by a clutch system with two gear levels. They ensure that the individual wheels on the rear axle receive different levels of torque.

The clutches are activated by an electrohydraulic actuator. Depending, for example, on the steering angle, lateral acceleration, yaw angle and driving speed, the system calculates the right distribution of wheel torque for every driving situation. In this way the power is specifically channelled to the outer rear wheel when steering or accelerating into a corner. The effect: The vehicle is effectively pushed into the corner and follows the angle of the front wheels. The variable left

and right driving forces also help to stabilise the steering and the usual steering corrections are no longer required.

The sports differential has a reaction time of less than 100 milliseconds and is therefore faster than the ESP. And while ESP can only take effect once there is a certain difference between the steering angle and the rotational movement of the vehicle, the sports differential influences the dynamics of the vehicle before this occurs.

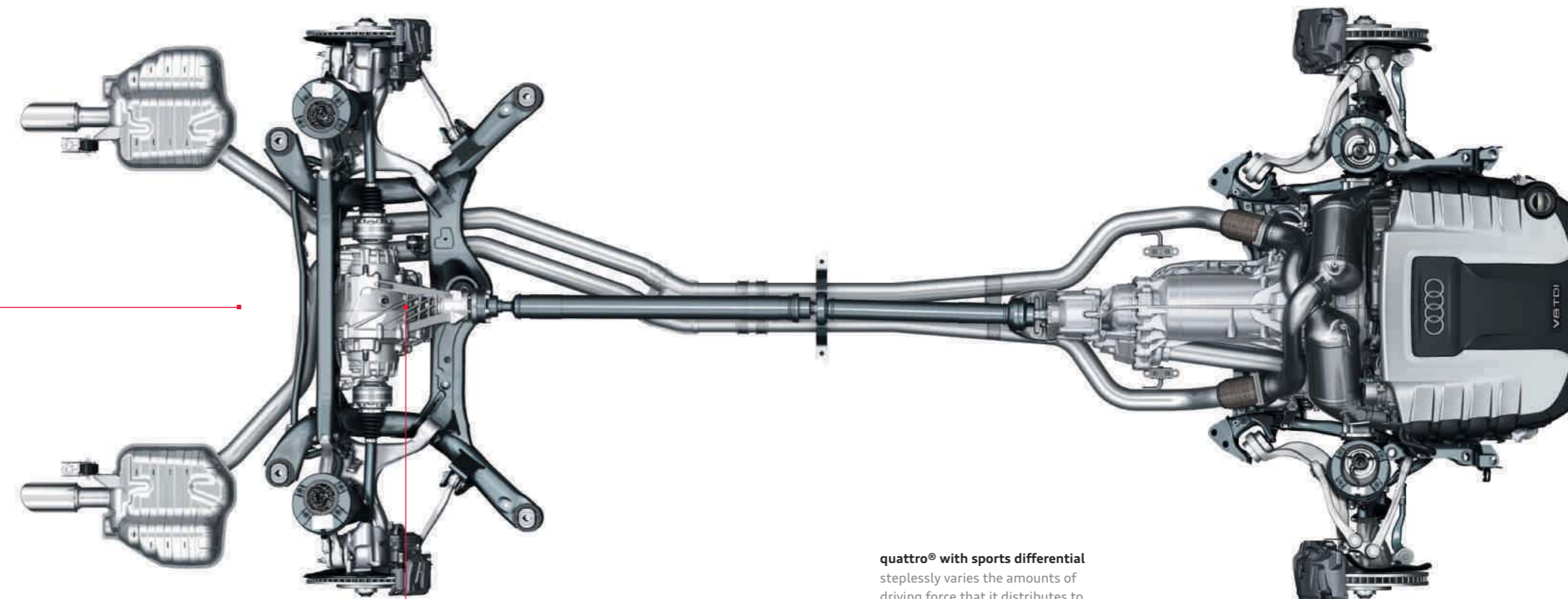

**quattro® with sports differential** steplessly varies the amounts of driving force that it distributes to each rear wheel and ensures high cornering agility and impressive driving dynamics.

# < 300 °C

**Conventional light bulbs reach temperatures of up to 300 °C.** Due to their sophisticated technology, LED lights are somewhat more sensitive and should not get hotter than 150 °C. Because of the engine, the temperature of the area around the headlights is already around 120 °C. In theory, then, LED headlights would need an additional cooling system to be able to work. However, the Audi engineers did not want to spoil the good low-energy credentials of the LED headlights, so they quickly developed something completely new: a fan which directs heat away from the LED chips. The special feature of this fan is its additional benefit. The high operating temperature of standard bulbs means that they can defrost the headlights, which LEDs cannot. The newly developed fan directs warm air from the LED chips directly to the headlight lens and thus defrosts them and prevents them from misting up.

Subject: Light

LED headlights



Daytime running lights

Main beam

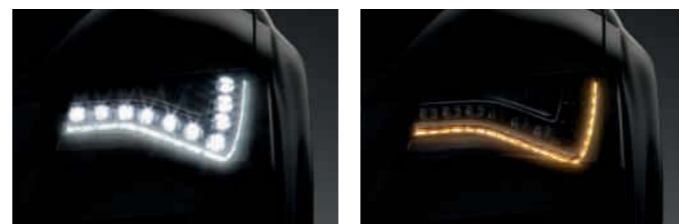

Dipped beam

Indicator

Indicator light  
Dipped beam with 10 individual LEDs  
Main beam  
Daytime running lights  
All-weather light consisting of turning light and 8 LEDs from the dipped beam  
Turning light

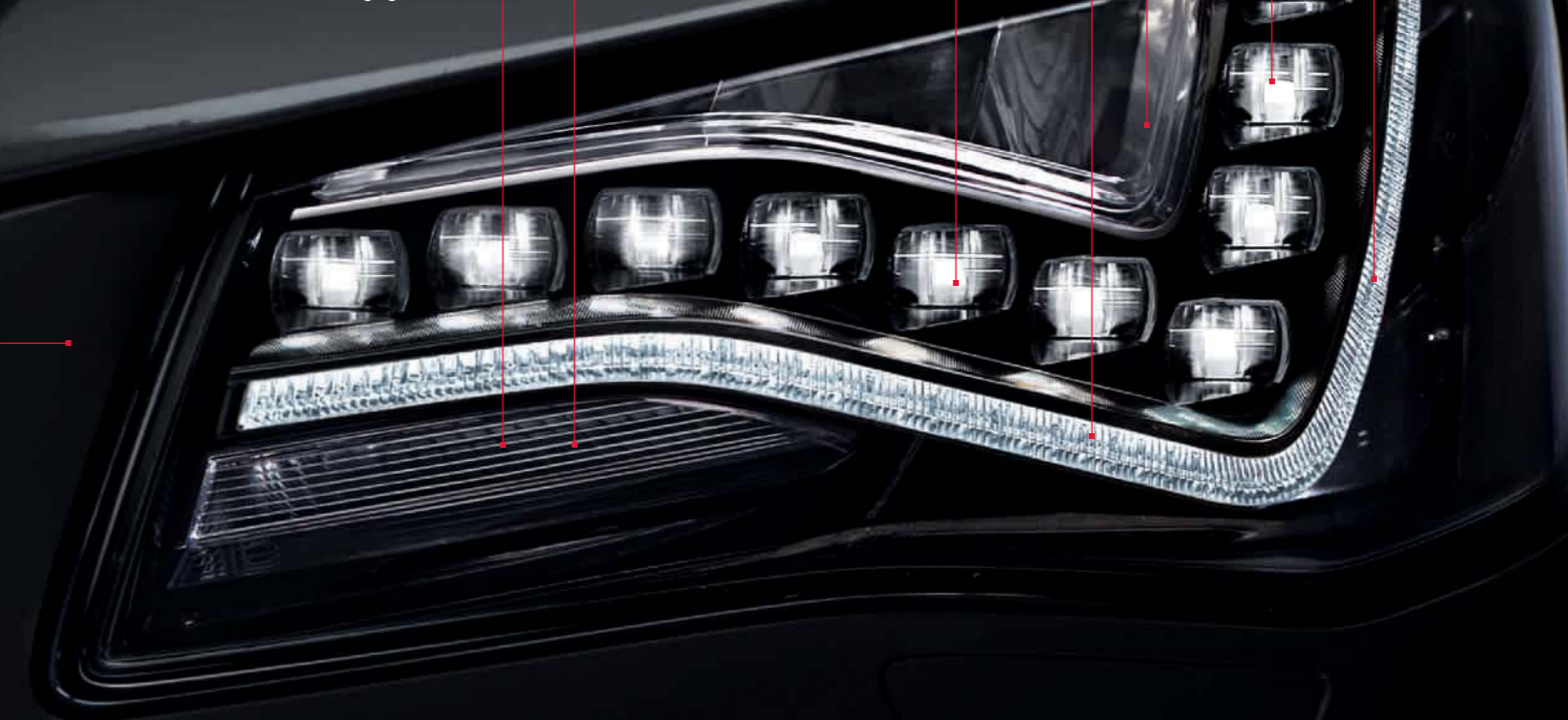

## Less energy, more light: the first Audi A8 with full-LED headlights.

In 2008, the Audi R8 set the standard as the first vehicle with full-LED headlights. Now this special lighting is available for the Audi A8 too on request. Full-LED headlights not only require less energy than standard lighting systems, but also provide a brighter light which is perceived to be much more pleasant. The dipped beam consists of a distinctive line of ten individual light modules. This makes the Audi A8 unmistakable, even

at night. Main beam, daytime running lights and indicators are also produced using LED technology. The use of the same material for all functions makes completely new lighting effects possible. The Audi A8, therefore, has the right light for every situation: it has a motorway light which, at speeds above 110 km/h, automatically more than doubles the range of the light cone (from approx. 70 m with dipped beam to 150 m with

motorway light). In addition, the A8 has a combined daytime running light/indicator light unit and an all-weather light which makes conventional fog lights superfluous.

The individual LED modules are skilfully controlled to redistribute the light, reducing glare from rain or fog.



Because in an emergency, a second is 0.9 seconds too long:

## Audi pre sense.

The Audi A8 does not only come with many new technical innovations but also with something extra special: a sort of sixth sense – or Audi pre sense. Various vehicle systems can categorise different driving situations and, where necessary, implement actions for preventive occupant protection or for collision reduction.

Front and rear are both equipped with radar sensors (depending on which features have been ordered) to measure the areas in front of and behind your Audi A8. A video camera also monitors the road in front of you. This is located in the area of the internal rear-view mirror – the highest possible point inside the vehicle – and delivers 25 pictures per second with a resolution that has yet to be matched in the field of automotive engineering. In addition, the ESP control unit trans-

mits further data. Using these different sources of information, Audi pre sense can create a very realistic picture of the vehicle's surroundings.

Audi pre sense basic includes various preventative passenger protection systems that are activated in the event of a critical driving situation. These include tensioning of the front seat belts, activation of the hazard warning system and closing of the sliding sunroof and windows.

Audi pre sense front additionally monitors the traffic ahead via the radar sensors of the optional adaptive cruise control with Stop&Go function. Also included is the Audi braking guard, which warns the driver in critical situations and increases the braking power if necessary. In extreme situations, the preventive protection system is activated.

Audi pre sense rear monitors the traffic behind the vehicle with the help of the rear sensors of the optional Audi side assist and, in addition to the actions of the Audi pre sense basic, brings the optional memory seats into a position favourable in case of an accident from the rear. If fitted, the pneumatic side bolsters are filled to better support the occupants.

Audi pre sense plus is included if ordering the optional adaptive cruise control with Stop&Go function and Audi side assist. In addition to the functions of Audi pre sense front, Audi pre sense plus activates the Audi braking guard in certain situations when a collision is unavoidable and initiates a full braking action to minimise the severity of the crash as much as possible.

# Because they protect something very valuable,

## you will find our most outstanding employees working in the area of vehicle safety.



The development of a new vehicle includes a number of crash tests. At first as virtual tests on computers, then later with the car itself in the halls of the Audi Vehicle Safety Department. Our engineers do not just evaluate data from their own series of tests but also data from real accidents recorded by accident researchers and scientists from the Audi Accident Research Unit (AARU). This was founded in 1998 and works together with the police and doctors to establish

the most accurate information possible about accidents. With the help of this information, our series of tests is continually being refined.

Vehicle safety at Audi focuses on people. This means we develop anticipatory systems that support you during every journey and that will help you to avoid accidents where possible. To achieve this, we put ourselves in your position and it's from this basis that our technical innovations

arise – along with the required safety tests. This also means that completely new tests sometimes need to be developed to check the new technology. That's why we have designed a new methodology for research into anticipatory Audi pre sense systems which is called "Virtual Test Drive". On a test track, drivers can be shown virtual obstacles and other vehicles via video goggles and, in this way, many critical driving manoeuvres can be re-enacted in a short amount of time.

adaptive cruise control with Stop&Go function

Audi lane assist

Audi side assist

**adaptive cruise control with Stop&Go function including Audi pre sense front\*** is the heart of the driver assistance systems. On clear roads, it maintains a chosen speed and keeps the correct distance from the vehicle in front. In slow moving traffic or in a traffic jam it regulates slowing down, starting up and crawling through traffic. At all times radar sensors, a video camera and the sensors from the parking system monitor the area around the Audi A8. Should they detect an obstacle, the driver is alerted by a signal tone and a display on the driver information system.

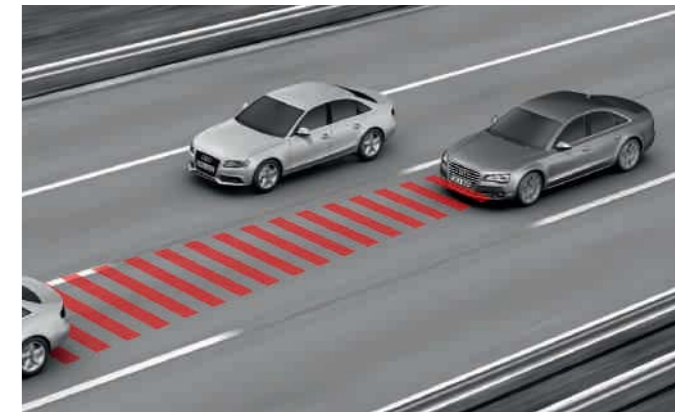

**Audi lane assist\*** supports you when travelling at speeds of around 60 km/h or above, when you inadvertently drift out of your lane, for example, through inattentiveness. Lane markings are identified by a camera located behind the windscreen. When the lane markings are crossed, the steering wheel vibrates to give the driver a warning. If the indicator has been activated, there is no warning. Identification of lane markings by the sensors is dependent on the weather, lighting and quality of the marking. Audi lane assist can, therefore, only provide assistance to the driver – who is naturally required to remain attentive while driving. The timing of the warning and the strength of the vibration can be adjusted to one of 3 levels in the MMI.

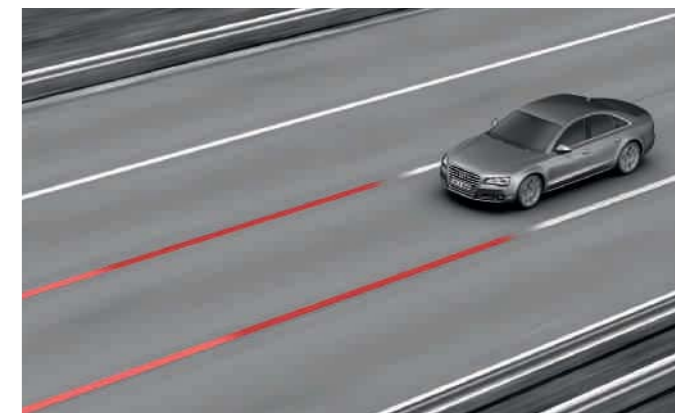

**Audi side assist inclusive Audi pre sense rear\***: Displays are integrated into the exterior mirrors. Operational from a vehicle speed of 30 km/h, Audi side assist uses 2 radar sensors (with a range of approx. 70 m) to measure the vehicle's distance from other detected vehicles, as well as the speed difference between them. If Audi side assist classifies the speed difference and distance as being critical in the event of a lane change manoeuvre, a display will appear in the respective exterior mirror (information stage). This display will only be noticed by looking at the exterior mirrors. When the indicator is on and Audi side assist detects a vehicle approaching and rates the situation as critical, the relevant display on the exterior mirror flashes repeatedly (warning stage). The brightness of the display can be set to one of 3 levels in the MMI.

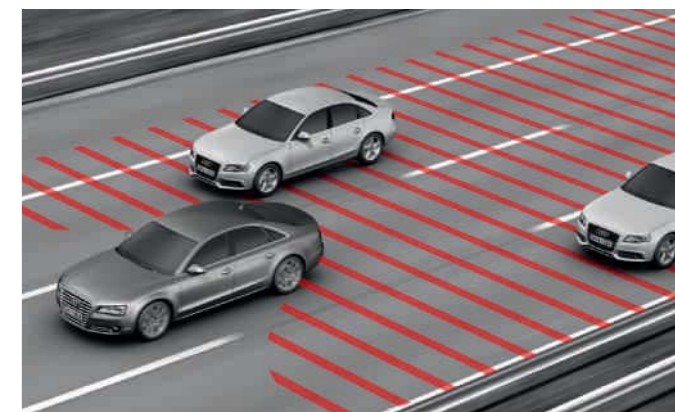

**We always do our very best**, but remember: the systems can only work within system limits.

\*Optional equipment.

# Day and night. What is the difference?



The human eye is one of the most sensitive sensory organs. However, sometimes it may still miss something. For example, when it is dark or you have been dazzled. We always do our best to help you in these situations. The optional night vision assistant with highlighting of detected pedestrians records the area in front of the vehicle using a thermal imaging camera and marks any identified pedestrians located between 15 and

90 metres away. Should the system detect an imminent collision between the vehicle and an identified pedestrian, then the colour of the marking will change to red and a warning tone will sound. The night vision assistant can be turned on or off via a button on the rotary light switch. Pedestrian markings, the warning signal and picture contrast can be configured in the car menu.

Pedestrians identified in the detection area are highlighted in yellow.



Should the system detect an imminent collision, the marking turns from yellow to red and a warning tone will sound.



Schematic diagram

## Efficiency: standard in every Audi.

The direct route to enhanced efficiency is via innovation. For decades, Audi has been continuously providing decisive impetus for the entire automobile industry, thereby proving that effective efficiency is the result of a sustainable strategy. That's why fuel consumption and emission-reducing measures are fitted as standard to all Audi models. The extensive technologies are combined in a model-specific manner and are implemented consistently throughout the entire vehicle fleet.

The Audi Space Frame (ASF), which is used in a range of Audi models, is a milestone in the extensive experience Audi has gained with lightweight construction. With this revolutionary construction method, the weight of the body shell is reduced by about a third in comparison with conventional steel construction. The latest innovation in lightweight construction: the weight-reducing aluminium hybrid construction used in the new Audi A6.

Furthermore, with the TDI, Audi has developed one of the world's most successful diesel technologies. The combination of direct diesel injection and turbocharging provides high efficiency and superior engine power. Current highlight: the 3.0 TDI clean diesel in the Audi A4 Saloon<sup>1</sup>. It already fulfils the EU6 emission standard that does not come into force in Europe until 2014.

Also noteworthy: the downsizing technology of the TFSI<sup>®</sup> petrol engines. Five times in succession, the 2.0-litre TFSI engine has been voted "Engine of the Year"<sup>2</sup>. A new evolutionary stage in efficiency is set by Audi with the Q5 hybrid quattro: as a pioneer of electrical mobility, it marks the entry into a future that in the long term will be emission-free.

The potential of the frugal TDI and TFSI engines is brought particularly efficiently onto the road with the S tronic dual-clutch transmission with low engine speeds and shorter gearshifting times. And the aerodynamic design of the Audi bodies provides additional savings in fuel by combining low air resistance with low levels of lift.

All measures contribute towards a perfect combination of efficiency and sportiness in every Audi. Today – and also in the future. So that you can at all times feel the demands that we have always placed on ourselves: Vorsprung durch Technik.

<sup>1</sup> Fuel consumption in l/100 km: urban 8.7; extra-urban 5.5; combined 6.7; CO<sub>2</sub> emissions in g/km: combined 175.

<sup>2</sup> The renowned "International Engine of the Year Awards" are awarded by Great Britain's car magazines: [www.ukipme.com/engineoftheyear](http://www.ukipme.com/engineoftheyear)



## Quality is evident in the whole. And in each small detail.

When we design a new Audi, we not only pay attention to an exceptional design and matchless driving characteristics. Above all, we prioritise visible, perceptible quality which you can grasp with all your senses.

One example of this is the optional Valonea leather for the comfort seat with seat ventilation. The name hints at its purely plant-based tanning process, since the tanning agents are derived from different types of oak. This gives a natural feel and a wonderful, soft surface. Over time, this leather develops its own individual, unmistakable character, full of warmth and with a fine, classic leather aroma.

Valonea leather is used in an unmistakable combination with Nappa deerskin in the Audi A8. Despite its soft appearance, this unique leather is extremely robust. It has a distinctive structure and a subtle two-tone colour which emphasises the natural character of the leather.

Completely new procedures have been developed for the seat covers. The unique form of the seats in their different versions, for example the diamond-patterned design of the comfort sports seats, required the application of a new technique for perforating the material which would permit the use of decorative seams on a seat with a large perforated area. Without forfeiting precision.

The woods for the inlays in the interior are a further special feature. The thin veneer boards are stripped from the trunks, roots and so-called burls. A set of parts for a vehicle generally comes from one burl or trunk, so that the individual parts match each other. After the veneer has taken its final form, our best tool comes into play: the human hand. The edges of the veneers are lightly sanded by hand to achieve the perfect form. The last coat of varnish which seals the edges is also applied by hand.

So as well as a great deal of innovative technology and many years of experience, you can always enjoy an element of uniqueness in your Audi. And uniqueness of a high quality.



Because nobody knows your taste as well as you do: Audi exclusive.



Each year Audi sells hundreds of thousands of vehicles. Yet they only sell yours once. How is that possible? With the quattro GmbH service, which makes your Audi unmistakable: Audi exclusive. Paint customised to your concept, fine leather, high-quality Alcantara and selected woods and trim; it is these materials and the precise workmanship which give your Audi its own unique personality. Your Audi partner and the Audi Forum Neckarsulm customisation studio await your wishes.



Comfort seats in powder beige with piping and seams in smoky blue, inlays and selector lever in Oak sepia



Audi exclusive selector lever in Oak sepia



Audi exclusive inlays in Oak sepia



Comfort seat in Audi exclusive powder beige leather with piping and contrasting seams in smoky blue



Audi exclusive leather steering wheel rim and airbag cover trimmed in Havana brown leather with contrasting black seams



Inlays Audi exclusive in Fine grain ash nougat, Audi exclusive leather upholstery and trim in Havana brown and black



Havana brown carpet with black piping



Audi exclusive paint in Sand Beige, pearl effect

## Audi design selection balao brown: consummate style.



The Audi design selection balao brown fulfils quite sophisticated expectations – with refined interior colours, special materials and a range of equipment that is tailored to provide you with the ultimate in personal comfort.

In the interior the seats, headlining and lining are offered in specially coordinated colour shades: balao brown and snow white. Inlays in natural fine grain ash nougat, balsamic brown and brushed aluminium silver provide refined accents. Comfort functions such as seat ventilation, massage function and the ambient lighting create an individual atmosphere of comfort and relaxation. Specific details on the range of the equipment package can be found on page 87.

## Audi design selection brass beige: harmonious exclusivity.



A second option for driving in exceptional style: Audi design selection brass beige. It likewise offers exclusive interior colours, high-quality materials and exceptionally comfort-oriented equipment.

From the moment you first see the seats, they captivate: soft brass beige Valcona leather is completed with seams in granite grey. Additional colours that give a refined look to the interior: the headlining in Alcantara snow white and the inlays in fine grain birch wood pearl beige and brushed aluminium silver. Just sit back, relax and take in the full extent of the luxurious ambience. Specific details on the range of the equipment package can be found on page 87.

Paint finishes



Brilliant Black

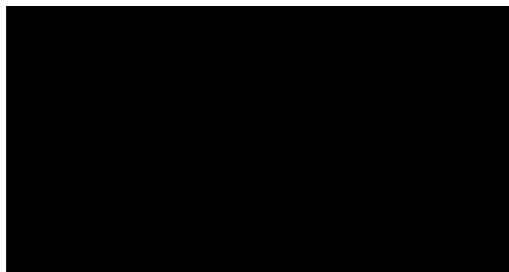

Emerald Black, metallic



Ibis White

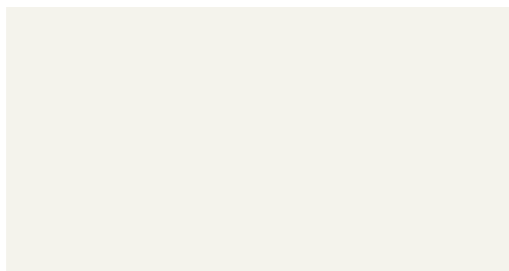

Oolong Grey, metallic

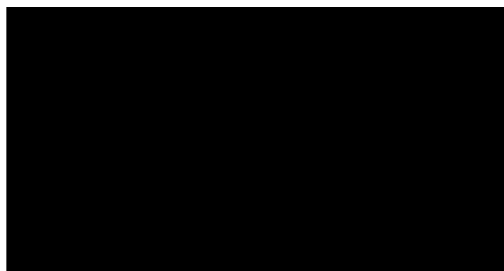

Havana Black, metallic



Quartz Grey, metallic



Paint finishes



Ice Silver, metallic



Night Blue, pearl effect



Glacier White, metallic

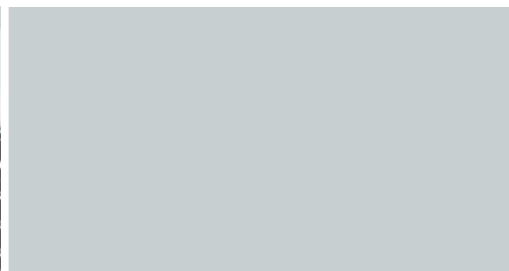

Impala Beige, pearl effect



Phantom Black, pearl effect

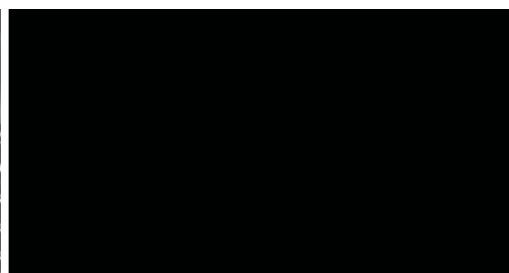

Audi exclusive individual paint finishes  
Individual choice of colour  
From quattro GmbH



**Standard seats, front**  
Can only be ordered in conjunction with Verdi cloth or Valcona leather

**Seat covers A8/A8 L**



Valcona leather, black



Valcona leather, titanium grey



Valcona leather, velvet beige



**Comfort sport seats, front with/without seat ventilation\***  
With wood trim on the back of the front seats, memory function for driver and front passenger seats, steering wheel, exterior mirrors, head restraints, seat belt height at front and heated, electrically adjustable, folding and automatically dimming exterior mirrors. (Can only be ordered in conjunction with Valcona leather or Alcantara/Leather)

\*The Audi exclusive range is also available for this seat.

**Seat covers A8/A8 L/A8 L W12**

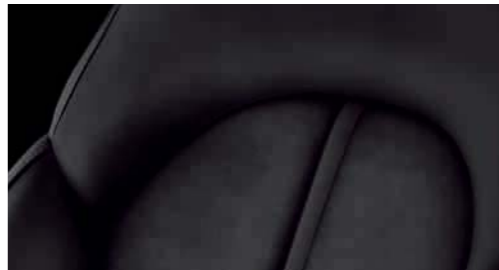

Alcantara/Leather, black



Alcantara/Leather, titanium grey

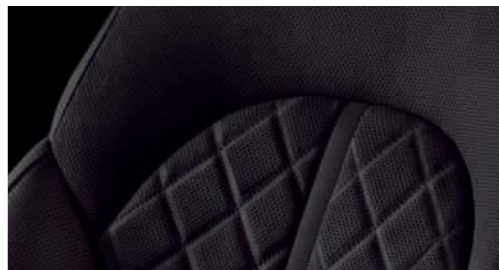

Valcona leather, black



Valcona leather, nougat brown



Valcona leather, titanium grey



Valcona leather, velvet beige



Seat covers A8/A8 L/A8 L W12

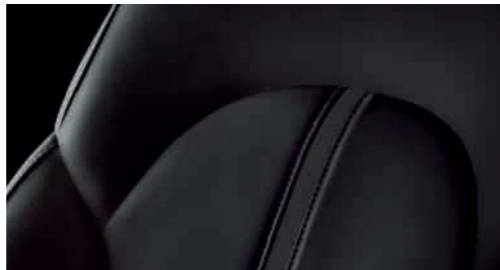

Valcona leather, black



Valcona leather, nougat brown



Valcona leather, titanium grey



Valcona leather, velvet beige



Valcona leather, silk beige

Seat covers A8/A8 L/A8 L W12



Natural leather, black\*



Natural leather, nougat brown\*



Natural leather, velvet beige\*



Natural leather, titanium grey\*



**Audi exclusive leather upholstery and trim**  
Individual choice of colour for leather/seams/piping  
From quattro GmbH

**Comfort seats, front**  
With wood trim on the back of the front seats, memory function for driver and front passenger seats, steering wheel, exterior mirrors, head restraints, seat belt height at front and heated, electrically adjustable, folding and automatically dimming exterior mirrors. (Can only be ordered in conjunction with Valcona leather or Natural leather)



**Comfort seats, front with optional seat ventilation**  
 The comfort seat is available on request with seat ventilation and heating; functions are as per the comfort seat specification. (Can only be ordered in conjunction with Valcona leather, Natural leather or Valonea leather)

Seat covers A8/A8 L/A8 L W12



Valcona leather, black



Valcona leather, nougat brown



Valcona leather, titanium grey



Valcona leather, velvet beige



Valcona leather, silk beige

Seat covers A8/A8 L/A8 L W12



Valcona leather, balao brown<sup>1</sup>



Natural leather, black



Natural leather, nougat brown



**Audi exclusive leather upholstery and trim**  
 Individual choice of colour for leather/seams/piping  
 From quattro GmbH



Valcona leather brass beige<sup>2</sup>



Natural leather, titanium grey



Natural leather, velvet beige



Valcona leather, black<sup>3</sup>



Valcona leather, nougat brown<sup>3,4</sup>

Please find out from your local Audi partner which equipment is standard and what optional equipment is available in your country.

<sup>1</sup> Can only be ordered in conjunction with the Audi design selection balao brown. <sup>2</sup> Can only be ordered in conjunction with the Audi design selection brass beige. <sup>3</sup> Head restraints, cushioned hand rests and selector lever in deerskin. <sup>4</sup> For more information on when this feature will be available, please contact your Audi partner

## Seat covers



**Verdi cloth**  
for standard seats

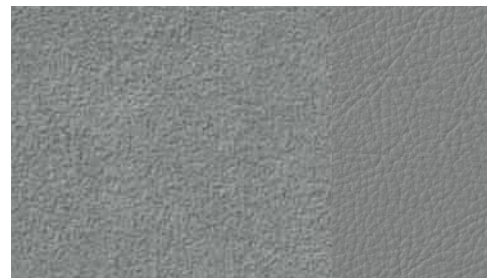

**Alcantara/Leather combination**  
the Alcantara/Leather combination lends the comfort sports seat an exclusive, sporty look. The seat centre sections in Alcantara provide exceptionally good support and are well suited for dynamic driving styles; the side bolsters made from the finest Valcona leather complete the look. Thanks to rapid temperature equalisation, this combination offers high levels of seating comfort and a good seating climate. It is particularly hard-wearing, easy to clean and resistant to wear and tear



**Valcona leather**  
a high quality leather, with contributes to the elegant charisma of the interior. The low use of lacquer allows the material to breathe whilst the non-grained surface underlines the sophisticated character. Valcona leather is tanned without the use of chromium, dyed through and treated with non-fading colour pigments

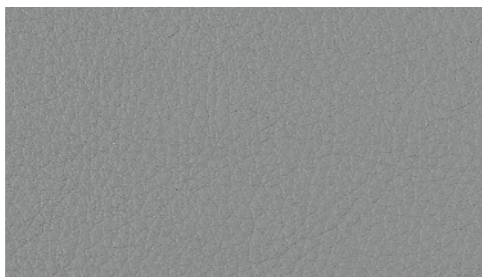

**Natural leather**  
the natural appearance of natural leather imparts a luxurious character. Low use of lacquer and the non-grained surface help maintain the natural characteristics of the leather and create an excellent seating climate. Over time, characteristic signs of use create a typical patina. Natural leather is tanned without the use of chromium, dyed through and treated with non-fading colour pigments

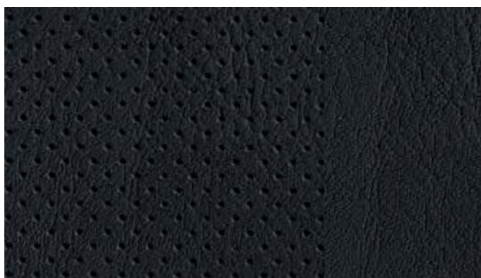

**Valonea leather**  
a special manufacturing method, in which the leather is tanned using plant extracts, makes this natural leather really exclusive. It is completely dyed through, is not coated in lacquer and yet is water and dirt-repellent. The natural characteristics of the leather are shown to their best advantage and the leather boasts excellent breathability, softness and an incomparable natural feel. The plant-based tanning process creates a special microclimate that ensures exceptional moisture control. The characteristics of this leather give it a very special aura distinguished by an agreeable feeling of warmth and an exquisite classic leather aroma. The head restraints, selector lever and cushioned hand rest, all in the same colour as the seats, are in soft Nappa deerskin whose unique natural surfaces are a perfect match for the quality of the Valonea leather

**Audi exclusive leather upholstery and trim**  
available in quality Valcona and Alcantara/Leather combination. 4 different packages are available. Any of the colours can be selected for the leather, seams and piping to suit your own individual taste. From quattro GmbH



**Leather package**  
(scope 1) centre console and knee pad, door arm rest upholstery and steering wheel airbag cover in Fine Nappa leather with decorative seams



**Extended leather package**  
(scope 2) in addition to package 1, lower door trim and door pockets, bottom side of the instrument panel and glove compartment and MMI fascia in Fine Nappa leather with decorative seams

## Seat covers



**Full-leather package**  
(scope 3) in addition to the extended leather package, top side of instrument panel, door rails, front-seat trim and backrest covers, head restraint lining front and rear in Fine Nappa leather with decorative seams; includes headlining in Alcantara and electric sunblinds for the rear window and the rear door windows

**Audi exclusive leather upholstery and trim (package 1)**  
available in Valcona leather. Leather trim for: Seats, centre armrest and door trim inserts. Individual choice of colour for the leather, the decorative seams from a range of 15 different Audi exclusive colours. If combined with the individual rear seats package, the comfort seats feature piping in any choice of colour. From quattro GmbH

**Audi exclusive leather upholstery and trim (package 2)**  
available in Valcona leather and Alcantara/Leather. Contents in addition to package 1 are: Centre console with knee padding, door armrest upholstery. Choice of leather or Alcantara for seat centre sections and door trim inserts. From quattro GmbH

**Audi exclusive leather upholstery and trim (package 3)**  
available in Valcona leather. Contents in addition to package 2 are: Lower door trim and door pockets, underside of instrument panel, and glove compartment and MMI fascia. From quattro GmbH

**Audi exclusive leather upholstery and trim (package 4)**  
available in Valcona leather and Alcantara/Leather. Contents in addition to package 3 are: Top side of instrument panel, door rails, seat linings, front and rear head rest linings, steering wheel incl. airbag cover and body. Top side of instrument panel available in the following Audi exclusive leather colours: chestnut brown, classic red, crimson red, havana brown, iceland green, jet grey, night blue, saddle brown, smoky blue. Individual choice of colour for the leather, the decorative seams and piping (when comfort seat is ordered). From quattro GmbH

**Audi design selection balao brown**  
an exclusive combination of a refined interior colour, special materials and an extended range of features. The package includes seats in balao brown Valcona leather with accordion pleats, contrasting seams and piping in snow white; rear parcel shelf in balao brown Alcantara, headlining, upper pillar trim and sun visors in snow white Alcantara; top side of dashboard in mocca brown with lock seams in snow white/mocca brown, dashboard underside in balao brown, centre console and knee padding in balao brown with lock seams in snow white, upper inlay in fine grain ash natural balsamic brown, lower inlay in brushed aluminium silver. Additional equipment: Metallic or pearl effect paint, comfort seats with memory function, electric sun blinds on the rear window and on the rear door windows, heated seats front and rear, seat ventilation and massage function at the front; dimming exterior mirrors; 4-zone automatic air-conditioning; front comfort arm rest; ambient lighting; full leather package; extended aluminium look on interior; “design selection” emblem in the doors

**Audi design selection brass beige**  
an exclusive combination of a refined interior colour, special materials and an extended range of features. The package includes seats in brass beige Valcona leather with accordion pleats and contrasting seams and piping in granite grey; rear parcel shelf in brass beige Alcantara, headlining, upper pillar trim and sun visors in snow white Alcantara; top side of dashboard in granite grey with seams in brass beige, dashboard underside in brass beige, centre console and knee padding in brass beige with lock seams in granite grey, upper inlay in fine grain birch wood pearl beige, lower inlay in brushed aluminium silver. Additional equipment: Metallic or pearl effect paint, comfort seats with memory function, electric sun blinds on the rear window and on the rear door windows, heated seats front and rear, seat ventilation and massage function at the front; dimming exterior mirrors; 4-zone automatic air-conditioning; front comfort arm rest; ambient lighting; full leather package; extended aluminium look on interior; “design selection” emblem in the doors

## Headlining



**Headlining in Alcantara**  
in black, lunar silver or silk beige to coordinate with the selected interior colour. Headlining, rear parcel shelf, upper pillar trim and sun visors in Alcantara. (Can only be ordered in conjunction with leather seat covers)

**Headlining**  
in cloth, in lunar silver or silk beige to coordinate with the selected interior colour

**Headlining**  
in black cloth

**Audi exclusive headlining in Alcantara**  
Pillar trims, sun visors and head lining roof panel in Alcantara; grab handles, coat hooks and light unit are colour-matched. Available in 9 different Audi exclusive Alcantara colours. From quattro GmbH

**Audi exclusive parcel shelf in Alcantara**  
From quattro GmbH

## Inlays A8/A8 L



Walnut tree root wood brown  
High gloss black



Fine grain ash velvet brown  
High gloss black

## Inlays A8/A8 L/A8 L W12



Walnut tree root wood brown  
Brushed aluminium silver

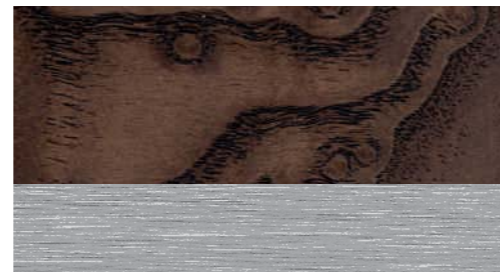

Fine grain ash velvet brown  
Brushed aluminium silver



Upper inlay in walnut tree root wood brown  
Lower inlay in high gloss black  
Aluminium look on the interior



Upper inlay in walnut tree root wood brown  
Lower inlay in brushed aluminium silver  
Aluminium look on the interior

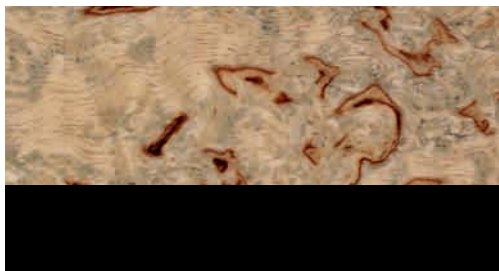

Fine grain birch wood pearl beige  
High gloss black



Vavona wood assam grey  
High gloss black

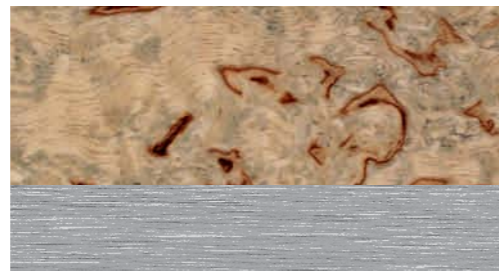

Fine grain birch wood pearl beige  
Brushed aluminium silver



Vavona wood assam grey  
Brushed aluminium silver



Upper inlay in walnut tree root wood brown  
Lower inlay in high gloss black  
Extended aluminium look on the interior



Upper inlay in walnut tree root wood brown  
Lower inlay in brushed aluminium silver  
Extended aluminium look on the interior

## Inlays A8 L W12



Piano finish black  
Brushed aluminium silver



Fine grain ash natural balsamic brown\*  
Brushed aluminium silver



**Audi exclusive inlays**  
in Madrone wood gold, Vavona wood bronze, Tamo ash natural dark brown, Piano finish black, Fine grain ash wood nougat, Fine grain myrtle wood nutmeg or Oak wood Sepia. From quattro GmbH

**Upper inlay**  
optionally in walnut tree root wood brown, Vavona wood assam grey, fine grain ash velvet brown, fine grain birch wood pearl beige, fine grain ash natural balsamic brown or piano finish black

**Aluminium look on the interior**  
for trim surrounds around the vents, MMI display fascia, operating switch for electromechanical parking brake and console for window controls

**Lower inlay**  
optionally in high gloss black or brushed aluminium silver

**Extended aluminium look on the interior**  
vent fascias and thumbwheels, openers of the fold-open compartments in the door armrests and aluminium switch integrated into the lower inlay; loading sill protector in stainless steel

## Wheels/tyres A8/A8 L



Forged aluminium wheels in 6-arm design, size 8 J x 17 with 235/60 R 17 tyres



Cast aluminium winter wheels in 7-arm design, size 7.5 J x 18 with 235/55 R 18 tyres, suitable for snow chains, permissible top speed 210 km/h

## Wheels/tyres A8/A8 L/A8 L W12



Cast aluminium wheels in 10-spoke Y design, partially polished, size 9 J x 19 with 255/45 R 19 tyres



Audi exclusive cast aluminium wheels in 5-double segment spoke design, size 9 J x 19 with 255/45 R 19 tyres

## Wheels/tyres A8/A8 L/A8 L W12



Audi exclusive cast aluminium wheels in 5-double segment spoke design, size 9 J x 20 with 265/40 R 20 tyres



Audi exclusive cast aluminium wheels in 5-arm structure design, size 9 J x 21 with 275/35 R 21 tyres

## Wheels/tyres A8 L W12



Cast aluminium wheels in 15-spoke design, partially polished, size 9 J x 19 with 255/45 R 19 tyres

## Wheels/tyres

**Run-flat tyres**

Journey can be continued on a flat tyre at a speed of up to 80 km/h and for a maximum distance of 30 km, without having to change the wheel. (can only be ordered in conjunction with 19-inch wheels)

**Wheel bolts, anti-theft**

can only be loosened with the adapter provided (Standard from 18-inch wheels)

**Tyre repair kit**

with 12 V compressor and tyre sealant, located under the loading floor cover in the luggage compartment, top speed 80 km/h

**Spare wheel, space-saving**

can only be ordered with jack

**Tyre pressure monitoring system**

visual and acoustic warning if the pressure drops in one or more tyres; display in the driver information system

**Vehicle tool kit**

in the luggage compartment

**Jack**

in the luggage compartment



Cast aluminium wheels in 7-arm design, size 8 J x 18 with 235/55 R 18 tyres



Cast aluminium wheels in 5-arm design, size 9 J x 19 with 255/45 R 19 tyres



Forged aluminium wheels Audi exclusive in 7-double spoke design, polished, two-tone, size 9 J x 20 with 265/40 R 20 tyres



Audi exclusive cast aluminium wheels in 5-arm rotor design, size 9 J x 21 with 275/35 R 21 tyres



Cast aluminium winter wheels in 5-arm design, size 7.5 J x 19 with 235/50 R 19 tyres, suitable for snow chains, permissible top speed 210 km/h



Forged aluminium winter wheels in 6-arm design, size 7.5 J x 17 with 235/60 R 17 tyres, suitable for snow chains, permissible top speed 210 km/h



Forged aluminium wheels in 10-parallel spoke design, partially polished, size 9 J x 20 with 265/40 R 20 tyres



Forged aluminium wheels Audi exclusive in 7-double spoke design, high-gloss polished finish, single colour, size 9 J x 20 with 265/40 R 20 tyres



Audi exclusive cast aluminium wheels in 5-arm rotor design, titanium look, high-gloss turned finish, size 9 J x 21 with 275/35 R 21 tyres



Forged aluminium winter wheels in 10-parallel spoke design, size 9 J x 20 with 265/40 R 20 tyres, not suitable for snow chains, permissible top speed 240 km/h

## Lights

**LED headlights**

featuring LED dipped beam, main beam, daytime running lights, indicators, static turning light, all-weather light and motorway light function with LED technology; includes main beam assist for automatic switching between main and dipped beams, an all-weather light function to reduce the risk of the driver being dazzled when visibility is poor (in fog, rain or snow) and an additional motorway light which automatically increases headlight range from a speed of approximately 110 km/h; LED technology allows near daylight illumination of the road; minimal energy requirements, long service life, and excellent recognition by other road users, thanks to the crisp Audi lighting pattern with day and night design configurations

**adaptive light**

consisting of dynamic cornering light and static cornering light; the dynamic cornering light infers the course of the road from the movement of the steering wheel and variably illuminates the corner or bend by pivoting the xenon headlights; operational between speeds of approx. 10 km/h and 110 km/h. The static turning light automatically switches on if the indicators have been engaged for a while at a low vehicle speed and illuminates the new direction in which the vehicle is travelling. The headlights also have 3 different light distribution modes which are activated depending on the vehicle speed: town light, motorway light and country light. These 3 light distribution modes of the adaptive light system are also controlled by the vehicle support based on navigation data function with the aid of the stored route data from the optional MMI navigation plus with MMI touch. The convenient functions of the lighting assistant are supplemented by the intersection light, which provides a broad spread of light from the front lighting system, and by the travel mode, with GPS-assisted switching between right and left-hand drive modes

**adaptive light including variable beam angle adjustment**

consisting of dynamic cornering light, static turning light and variable headlight range control; the dynamic cornering light infers the course of the road from the movement of the steering wheel and variably illuminates the corner or bend by pivoting the xenon headlights; operational between speeds of approx. 10 km/h and 110 km/h. The static turning light automatically switches on if the indicators have been engaged for a while at a low vehicle speed and illuminates the new direction in which the vehicle is travelling. The sliding headlight range control system uses a camera on the interior mirror to capture light sources from other road users. The range and width of the headlamp beam are continuously varied between dipped and main beam to suit ambient conditions, ensuring that the headlights provide good visibility without dazzling other road users. The headlights also have 3 different light distribution modes, namely town light, motorway light and country light, which are activated according to the speed. These 3 light distribution modes of the adaptive light system are also controlled by the vehicle support based on navigation data function with the aid of the stored route data from the optional MMI navigation plus with MMI touch. The convenient functions of the lighting assistant are supplemented by the intersection light, which provides a broad spread of light from the front lighting system, and by the travel mode, with GPS-assisted switching between right and left-hand drive modes

## Lights

**xenon plus including headlight cleaning system**

headlights with durable gas discharge technology for dipped and main beam ensure intensive illumination of the road and provide good uniformity and range both close up and in the distance. The automatic dynamic headlight range control prevents oncoming traffic from being dazzled; with low-energy LED daytime running lights and all-weather lights

**Light/rain sensor**

automatically switches the dipped beam or windscreen wipers on/off depending on the light and rain conditions; includes delayed deactivation/automatic activation of the rear lights/number plate lights when parking/opening the vehicle

**Interior and exterior lighting package**

**Exterior:** courtesy lighting on the underside of the door handles, LED door handle lighting to facilitate entry and exit in the dark; automatically activated when the doors are unlocked; includes passive internal door reflectors

**Interior:** luggage compartment and glove compartment lighting. LED "Polar" (cold white) lighting for: Roof module with reading lights, door pockets, front and rear footwells, inside door handles, door trim, make-up lights, light bands between the grab handles at the side, side-mounted reading lights at rear

**Ambient lighting**

anti-glare LED lighting for the passenger compartment. Comprises ambient light band in roof module and light bands between the grab handles at the sides to provide background lighting during the journey. Lighting for door pockets, footwells and inside door handles, reflected lighting for centre console and door inner panels to help occupants find their way around. Surround lighting for the centre console (floating effect), illuminated door sill trims and active door reflectors. Can be personalised by adjusting the brightness within 4 different zones, each with 20 dimming stages and by selecting one of three colour moods: Polar (cold white), Ivory (warm white) and Ruby/polar (red/cold white). Configured via MMI

**adaptive brake light**

brake light flashes during emergency braking to warn following traffic; hazard warning lights are activated automatically when the vehicle comes to a stop

**LED rear lights**

LED brake lights tail lights and indicators; faster activation means earlier recognition by the driver behind; reversing lights in white, 2 rear fog lights; 3rd high-mounted brake light in the rear window

**Additional reading lights in the rear**

Reading lights with LED technology, integrated into the vehicle headlining

**Make up mirrors and additional reading lights in the rear**

additional reading lights with LED technology and illuminated make up mirrors, integrated into the vehicle headlining

## Mirrors

**Exterior mirrors with integral LED indicators**

electrically adjustable, heated and folding, convex, flat or aspherical mirror glass, body-coloured housings

choice of:

**electrically adjustable, heated and folding, automatically dimming on both sides**

**electrically adjustable, heated and folding, automatically dimming on both sides with memory function**

**Interior mirror, automatically dimming**

recognises with the aid of a photocell when the headlights behind are too bright and dims automatically

## Roof systems

**Glass tilt/slide sunroof**

with tinted single-glazed safety glass and infinitely adjustable sun shield; wind deflector extends automatically in stages depending on roof opening and speed; convenience closing from outside via the central locking system and the radio-operated remote control

**Solar tilt/slide sunroof**

solar cells in the roof provide the power required to generate a continuous flow of air to reduce passenger compartment temperature when the vehicle is parked; operated like the glass sliding/tilting sunroof (but has no infinitely adjustable sun shield)

**Panoramic glass roof**

electrical activation to raise and open the front glass section as well as to raise the rear glass section, opens and closes automatically, tinted glass insert; including two electrically operated sun blinds for the glass parts, comfort closing from outside via the central locking system or the radio-operated remote control; ensures a comfortable interior that is flooded with light, good acoustics and low wind noise when the sunroof is extended or fully opened; improved interior climate by means of efficient ventilation whilst at the same time reducing draughts; includes make up mirrors and additional reading lights in the rear; with light-coloured and Audi exclusive individual paint finishes, the surrounding roof is painted in black

## Closing systems

**Engine start-stop button**

the engine is started and switched off via the engine start-stop button in the centre console; the key only needs to be carried with you

**Convenience key**

access authorisation system: The key only needs to be carried with you; the vehicle is locked from outside via buttons on all 4 door handles. The convenience key system also includes aluminium-look strips on all door handles

**Power-assisted closing for the doors**

doors that have not completely closed are pulled into the lock automatically; includes electric child locks on the rear doors, operated via the child lock buttons in the driver's door armrest

**Power-assisted closing for the luggage compartment lid**

automatically pulls the luggage compartment lid into the lock, should it not be completely engaged

**Luggage compartment lid, automatically opening**

The luggage compartment lid automatically swings open to facilitate loading when the luggage compartment lid is opened via the radio-operated remote control, the button in the driver's door or the soft-touch button in the handle recess of the luggage compartment lid

**Luggage compartment lid, electrically opening and closing**

opening via the radio-operated remote control, button on the driver's door panel or soft touch button in the luggage compartment lid handle recess; closing via button on inside of luggage compartment lid, the button in the driver's door or via the optional convenience key (long press); including power assisted closing

**Garage door opener (Homelink)**

programmable radio-operated remote control, operating buttons incorporated into the front roof module; can be used to open a number of garage doors and exterior gates; allows control of security and lighting systems; programming assistance provided by the MMI, code identification guidance and set-up assistance from appropriate logbook information on the screen. (For information on compatible hand-held transmitters, please contact your Audi partner or visit [www.eurohomelink.com](http://www.eurohomelink.com).)

**Anti-theft alarm**

with tow-away protection, monitors doors, bonnet, luggage compartment lid and the interior: includes an electronic immobiliser, ultrasonic interior monitoring (can be deactivated) and back-up horn independent of the vehicle electrical system; tow-away protection via a vehicle angle of inclination sensor (can be deactivated); incorporated into the engine control unit; automatically activated by the vehicle key

**Fitting for Tracking Assistant**

fitting for connecting a Tracking Assistant that enables a stolen vehicle to be located

## Glazing

**Heat-insulating glass**

green tinted; windscreen made of laminated glass

**Double/acoustic glazing**

2 panes of glass bonded together by a plastic film; improves exterior noise insulation and theft protection

**Insulating/acoustic glass\***

2 panes of glass bonded together by a plastic film; improves exterior noise insulation and theft protection; with additional reflective coating to reduce the build-up of heat in the interior; varies by country: with viewing window for automatic toll collection devices

**Insulating/acoustic glass with windscreen heater\***

full-surface of windscreen heated without heating wires that might impair visibility; heating controlled via the deluxe automatic air-conditioner; makes rapid defrosting easier and ensures that the windscreen stays mist-free; varies by country: with viewing window for automatic toll collection devices

**Dark-tinted windows (privacy glazing)**

dark-tinted rear window, rear door windows and rear side windows. (Can only be ordered in conjunction with double glazing/acoustic glazing or insulating/acoustic glass)

**Sun blinds**

protects the rear passengers from direct sunlight; electrical version available for the rear windscreen and rear side windows

**Further exterior equipment**

**Provision for trailer towing hitch** includes the wiring up to the spare wheel well, fitting for the control units and adapted engine cooling. The set of parts for retrofitting is available from Audi Genuine Accessories.

**Trailer towing hitch** electrically swivelling, ball head and ball joint coupling made from forged steel, operated via buttons in the luggage compartment; includes trailer stabilisation system via the Electronic Stabilization Programme (ESP)

**Exhaust tailpipes**

dual-branch design, bright finish and round. (A8 and A8 L)

dual-branch design, trapezoidal, integrated into the bumper. (A8 L W12)

**Model name/logo**

on the rear, if required, vehicle can also be supplied without the model name and/or logo

**“quattro” logo**

on the radiator grille, on the rear and on the passenger side of the dashboard



**W12 logo**

in the radiator grille, on the front wings, on the tailgate and on the door sill trims

Please find out from your local Audi partner which equipment is standard and what optional equipment is available in your country.

**Seats/seating comfort**



**Rear seat system**  
three seats, with fold-out centre armrest



**Individual rear seats, electrically adjustable**  
three seater rear seat system with 2 electrically adjustable single seats; adjustment of fore/aft position, seat and upper backrest angle; pneumatic lumbar support, memory function for the single seats, rear comfort head restraints, 4-zone deluxe automatic air-conditioning, rear comfort centre armrest with wood trim and controls, electric sunblinds for the rear window and rear door windows, fore/aft position of front-passenger seat electrically adjustable from the rear. (Can only be ordered in conjunction with Valcona leather, Natural leather or Valonea leather)

**Memory function for standard seats**  
memory function for driver and front-passenger seats, steering wheel, both exterior mirrors, front head restraints and belt height; includes electrical adjustment of the front head restraint and belt height

**Seats/seating comfort**



**Individual rear seats, electrically adjustable, with full length, leather trimmed centre console**  
2 single seats in rear; electrically adjustable as the single seats in the rear; additionally with full-length leather trimmed centre console with armrest, wood trim, controls and 230 V socket; leather package and ambient lighting; additional storage possibilities in the centre console. (Can only be ordered in conjunction with Valcona leather, Natural leather or Valonea leather)



**Relaxation seat**  
2 single seats in the rear including luxurious relaxation seat behind the front passenger seat; with electrical adjustment of fore/aft position, seat and upper seat backrest angle, pneumatic lumbar support, memory function for the single seats, comfort head restraints front and rear; relaxation seat including footrest in the back of the front passenger seat, front passenger seat adjustment controllable from the rear; 4-zone automatic air-conditioning, seat ventilation and seat heating front and rear including a full length, leather trimmed centre console with arm rest, wood trim, controls and 230 V socket; leather package and ambient lighting; additional storage possibilities and extendable table in the centre console; including pneumatic massage (4 programmes for the relaxation chair, 2 programmes for the single seat and 5 programmes for the driver's seat), remote control for seat massage (only for relaxation seat), Rear Seat Entertainment; front passenger seat only available with restricted functions (without adjustable upper backrests, head restraint height, lumbar support, seat and backrest side bolsters; seat ventilation only for the seat cushion, massage function not available). (Can only be ordered in conjunction with Valcona leather or Natural leather)

## Seats/seating comfort

**Massage function, front**

massages the muscles of the driver and front passenger using 10 pneumatic cushions; 5 different programs (Wave, Tapping, Stretch, Lumbar, Shoulder) can be selected via multifunction switches on the seat; display in MMI. (Can only be ordered in conjunction with comfort seats and comfort sports seats)

**Massage function, front and rear**

Front seat massage function, additionally, for the outer rear seats; a choice of 2 programs (Wave, Tapping) each offering 3 levels of intensity; can be selected from the centre armrest. (Can only be ordered in conjunction with comfort seats and not in conjunction with Alcantara/Leather)

**Seat ventilation, front**

ventilation of the seat centre sections and thigh support for the driver and front-passenger seats. By drawing in air, the system ensures a pleasant seating climate can be enjoyed even in high ambient temperatures; adjustable in 3 stages. (Can only be ordered in conjunction with comfort seats in Valcona leather, Natural leather or Valonea leather and seat heating or massage function and not in conjunction with Alcantara/Leather.) Please note: if seat ventilation is fitted, the leather on the front and outer rear seats is perforated

**Seat ventilation, front and rear**

functions same as for front-seat ventilation plus ventilation for the outer rear seats. (Can only be ordered in conjunction with comfort seats in Valcona leather, Natural leather or Valonea leather and seat heating or massage function and not in conjunction with Alcantara/Leather.) Please note: if seat ventilation is fitted, the leather on the front and outer rear seats is perforated

**Comfort centre armrest, front**

divided for driver and front passenger, with fold-open storage compartments; infinite vertical/horizontal adjustment

**Centre armrest, front**

for driver and front passenger, one-piece, foldable

**Centre armrest, rear**

one-piece, foldable, with two integrated drinks holders and storage compartment; additional controls depending on which optional equipment has been selected for the rear compartment

**Grab handles with wooden segments**

not available for Fine grain birch wood pearl beige and Fine grain ash natural balsamic brown

**Comfort head restraints, rear**

manually adjustable side bolsters ensure high levels of comfort by providing good lateral support (can only be ordered in conjunction with comfort seats and comfort sports seats)

**ISOFIX child seat mountings for the two outer rear seats**

standard mounting for practical attachment of child seats in accordance with ISO standards

**Seat heaters, front**

for driver and front-passenger seats; heats the seat cushions, backrest surfaces and seat side bolsters and can be individually adjusted in 3 stages for each seat via a direct selection button on the A/C control panel

**Seat heaters, front and rear**

functions same as for front-seat heating; for the outer rear seats, can be regulated separately

**Foot rests at the rear**

in pairs, for comfortable travelling in the rear

**Audi exclusive rear foot rests**

colour matched to the Audi exclusive carpet. From quattro GmbH

## Steering wheels/selector levers/controls

**Leather-covered multifunction steering wheel in 4-spoke design with shift paddles**

with full-size airbag, multifunction operating concept for operation of radio, driver information system, including trip computer and – if fitted – speech dialogue system, telephone and audio sources; switching of driver assistance system displays in driver information system; shift paddles for changing gear in manual mode; control panel in black with aluminium look frame

**Leather-covered multifunction steering wheel in 4-spoke design with shift paddles, heated**

same as 4-spoke multifunction leather steering wheel with shift paddles but with additional heating function

**Steering wheel with electric angle and axial adjustment**

steering wheel electrically adjustable for height and reach, with automatic entry and exit function

**Leather-covered multifunction sports steering wheel in 3-spoke design, with shift paddles, heated**

same as 3-spoke multifunction leather sports steering wheel with shift paddles but with additional heating function

**Leather-covered multifunction sports steering wheel in 3-spoke design, with shift paddles**

with full-size airbag, multifunction operating concept for operation of radio, driver information system, including trip computer and – if fitted – speech dialogue system, telephone and audio sources; switching of driver assistance system displays in driver information system; shift paddles for changing gear in manual mode; control panel in black with aluminium look frame

**Steering wheel rim with wooden segments**

for multifunction steering wheel in 4 spoke design with shift paddles, available in walnut tree root wood brown. From quattro GmbH

**Selector lever in leather**

colour-matched to the selected vehicle interior colour (to match the top side of the dashboard); with shift-by-wire technology

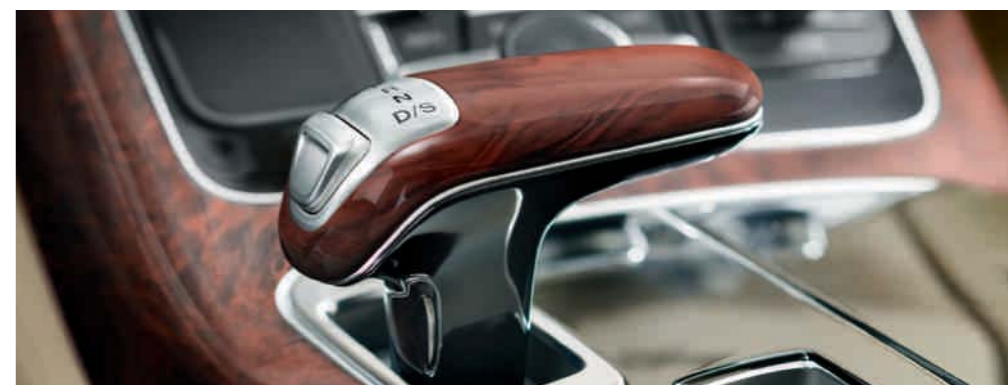
**Selector lever in wood**

matched to the selected inlay (can not be ordered in conjunction with Fine grain ash natural balsamic brown inlays)

**Audi exclusive selector lever in wood**

in 6 different Audi exclusive woods, not available in Tamo ash natural dark brown. From quattro GmbH

**Audi exclusive controls**

including steering wheel rim, air bag unit and selector lever in Audi exclusive leather. From quattro GmbH

## Climate control

**Deluxe automatic air-conditioning**

with indirect ventilation and sunlight-dependent control; separate temperature and air-flow control for footwell and head area for both driver and front passenger; ram air control, recirculation mode, residual heat utilisation, combined fine-particulate filter, air quality and humidity sensor and key-coded settings; choice of 3 climates: gentle, medium, intensive

**4-zone deluxe automatic air-conditioning**

deluxe automatic air-conditioning in addition to the A/C control panel for rear-compartment climate control in the rear centre armrest with separately adjustable temperature and blower settings and air distribution for the right and left-hand sides (rear-compartment A/C functions can also be adjusted from the front A/C control panel); greater comfort for the rear passengers and enhanced heating and cooling performance through the use of a second air-conditioning unit

**Auxiliary heating/ventilation**

The heater warms up the interior and removes ice from the windows without starting the engine; the auxiliary ventilation system supplies fresh air and reduces the temperature of the interior; with timer and departure time programming (an intelligent control function for time and energy-optimised calculation of heating duration); separate radio-operated remote control with illuminated display; choice of 2 heating modes: defrost mode for windows only, comfort mode that additionally preheats the passenger compartment

## Luggage securing and storage systems

**Storage compartments**

in the doors, the armrest and on the backs of the front-seat backrests (comfort seats and comfort sports seats only); spectacles compartment in roof module above the interior mirror; storage compartment in the front and rear centre armrests, glove compartment with light and ventilation provided by the deluxe automatic air-conditioning; aluminium-look handle

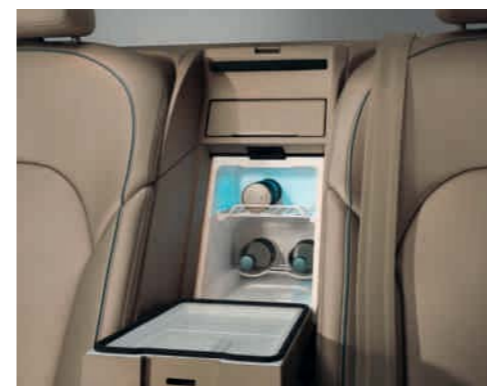
**Audi exclusive coolbox**

with compressor cooling technology, temperature adjustment range +6°C to -6°C, storage compartment for two 1 litre bottles lying down, additional storage compartment for cans and glasses, LED interior lighting. From quattro GmbH. From quattro GmbH

**Drinks holders**

two each at the front and rear, integrated into the centre console at the front and into the centre armrest in the rear

**Load-through facility with removable ski bag**

for the practical transportation of long objects, e. g. up to 2 pairs of skis

**Luggage compartment package**

comprising a luggage net, 2 fold-out bag hooks integrated into the top of the luggage compartment, a 12 V socket and an umbrella holder on the inside of the luggage compartment lid

**Audi exclusive fold away table**

manually operated, made of wood. Optionally on the backrests of the driver or/and front passenger seats. From quattro GmbH

**Audi exclusive personalisation of the fold away table**

Customisation of the real wood fold away table with a logo, coat of arms or other picture. The logo is visible when the table is closed and folded away. From quattro GmbH

## Further interior equipment



**Door sill trims with aluminium inlays**  
on A8 L W12 with W12 logo, illuminated



**Cigarette lighter and ashtray**  
front and rear. If not required, a 12 V socket is fitted in both locations instead

**Non-smoker package**

one 12 V socket and storage compartment each in the front and rear centre console

**230/115/100 V socket**

for direct operation of AC equipment with a power output of up to 150 watts, for electrical consumers such as power packs for laptops, mobile phones or games consoles; replaces 12 V socket/cigarette lighter in rear compartment. (Can only be ordered in conjunction with 4-zone deluxe automatic air-conditioning)

**Floor mats, front and rear**

in velour, coordinated with the carpet colour

**Audi exclusive carpets and floor mats**

with leather piping, front and rear, colours of mats and piping can be selected individually from different colours. From quattro GmbH

## MMI® and navigation system

### MMI®

integral operating concept consisting of MMI terminal (control unit) and MMI display (retractable high-resolution 8-inch colour display in high-quality Piano finish); retrieval of six freely assignable radio station presets



### MMI® Navigation plus with MMI® touch

includes Audi music interface and Bluetooth interface; hard disc navigation with topographical map display and places of interest and town models in 3D; destinations can also be entered via the speech dialogue system (whole-word entry of address in one sentence) or the MMI touch; choice of 3 alternative routes provided; scrolling along selected route and manoeuvring within the map; split-screen mode for route information (manoeuvring points, points of interest on motorways, TMC on route/TMC messages read aloud); intersection zoom function, motorway exits and lane recommendations also in driver information system; vehicle support based on navigation data. In conjunction with the Bluetooth car phone online, navigation with help of Google Earth images is available; Audi traffic information is also available online. (Can only be ordered in conjunction with MMI touch)

### MMI® touch

touch-sensitive control panel for intuitive operation of the MMI; letters and numbers can be entered without drivers taking their eyes off the road; contextual entry of letters and numbers for navigation destinations via handwriting recognition, selection from address book or entry of telephone numbers with acoustic acknowledgement, simple movement of navigation map and selection of points of interest; retrieval of 6 freely assignable radio station presets. (Can only be ordered in conjunction with MMI navigation plus)

### Navigation data (hard drive)

contains navigation data for the following countries (where digitised): **Europe:** Albania, Andorra, Austria, Belarus, Belgium, Bosnia-Herzegovina, Bulgaria, Croatia, Czech Republic, Denmark, Estonia, Finland, France, Germany, Gibraltar, Great Britain, Greece, Hungary, Ireland, Italy, Latvia, Liechtenstein, Lithuania, Luxembourg, Macedonia, Moldova, Monaco, Montenegro, the Netherlands, Norway, Poland, Portugal, Romania, Russia, San Marino, Serbia, Slovakia, Slovenia, Spain (including the Canary Islands), Sweden, Switzerland, Ukraine, the Vatican City, **North America:** Canada, Mexico, USA (incl. Hawaii, Puerto Rico, Virgin Islands). **Other regions:** AGCC (Oman, Qatar, Bahrain, Kuwait, Saudi Arabia, United Arab Emirates [UAE]), Asia Pacific (Singapore/Malaysia), Australia/New Zealand, China, Hong Kong/Macau, Japan, South Africa

### Vehicle support based on navigation data

adaptation of transmission and – if installed – adaptive cruise control with Stop&Go function or adaptive light using route data stored in the navigation system such as the sweep of bends and corners or road classifications. Example: use of vehicle lighting according to surroundings (urban area, non-urban areas, motorways and intersections)

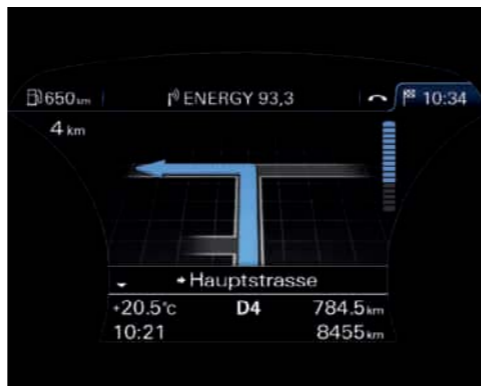

### Driver information system with 7" colour display

with high resolution TFT colour display directly in the driver's field of view; displays information about the radio frequency or the name of the station or the song, the driver assistance systems, the selected media, speed levels, outside temperature and other display content of the MMI systems, such as – if available – navigation, GPS clock, night vision assistant or the telephone menu, display for the trip computer with short and long-term memory as well as a digital speedometer and the door and luggage compartment monitoring system; the integral efficiency programme supports you with an overview of consumption data, a display of additional power consumers and saving tips for particularly economical driving; clearly arranged with easily readable header and status lines (tab concept); automatic brightness adjustment; can be operated via the leather-covered multifunction steering wheel

## Radio and TV systems

### Radio

can be operated via MMI; triple tuner with phase diversity for improved sound and reception; dynamic station list; TP memo function whilst driving; 2 SDHC memory card readers, juke-box (with 20 GB storage capacity, each MP3, WMA, AAC, MPEG-1, 2, 4, WMV, Xvid and playlist-compatible). Music and video files can be copied to and played from the integral hard disc; copy-protected music files (DRM) cannot be played.

### Single-DVD player

can be operated via MMI, located in centre console, supports audio formats (MP3, WMA and AAC-compatible), video formats (MPEG-1, 2, 4, WMV and Xvid-compatible) and playlists; music files with digital rights management (DRM) cannot be played

### DVD/CD Changer

can be operated via MMI or multifunction leather steering wheel; located in glove compartment, for 6 DVDs or CDs (MP3, WMA, AAC and WMV-compatible); music files with digital rights management (DRM) cannot be played

### Digital radio reception (DAB)

reception of digital stations with better sound quality in addition to analogue stations. Please note: reception depends on the availability of local digital networks; includes reception of DAB+ and DMB audio. With the DAB double tuner a second tuner permanently searches for alternative reception frequencies of the set station, and the station list is updated at the same time

### TV reception

reception of analogue and digitally-broadcast (DVB-T) unencrypted television stations (MPEG-2 standard), TV image, video text and EPG (Electronic Programme Guide). Facility to connect 2 external AV sources via the adapter cable (available from Audi Genuine Accessories). Please note: TV reception dependent on local analogue and digital network availability. No AV or TV video output when driving (audio output available when driving).

### Audi sound system

6-channel amplifier, 10 loudspeakers providing outstanding sound, 180 watts total output

### BOSE Surround Sound

surround sound reproduction with 14 loudspeakers, including centre speaker and subwoofer, 12-channel amplifier with total output of over 600 watts; Audio Pilot for noise-dependent volume adjustment; 5.1 Surround Sound reproduction is possible; the Acoustic Wave loudspeaker technology of the woofers in both front doors enables powerful and accurate bass reproduction



### Bang & Olufsen Advanced Sound System

surround sound reproduction with 19 loudspeakers (including subwoofer), each with its own amplifier channel; polished loudspeaker covers in aluminium; automatically extending acoustic lenses for excellent sound performance and perspective from every seat; the addition of tweeters, midrange speakers and woofers for the rear seats enables a broad stage effect to be created both front and rear; 14-channel DSP all-digital amplifier; all-digital highly efficient 5-channel ICE Power amplifiers for woofers and subwoofers; total output of over 1,400 watts; 5.1 Surround Sound reproduction possible; privacy function: encapsulated loudspeaker casings minimise escape of sound to the outside of the vehicle and provide privacy, for example when making telephone calls in hands-free mode; a precisely defined loudspeaker effect has also been achieved; noise-dependent volume adjustment

## Radio and TV systems



**Audi music interface, part of the MMI® navigation plus with MMI® touch** for connecting generation 4 and higher Apple iPods, an Apple iPhone (music functionality) as well as USB storage media and MP3 players. The Audi music interface is housed in the centre console; it is operated via the MMI or the multifunction leather steering wheel. Please note: can only be used with a special adapter cable (Audi Genuine Accessories). For information on compatible MP3 players, please contact your Audi partner. (Can only be ordered in conjunction with MMI navigation plus or MMI touch.)

### Adapter cable set for Audi music interface

consisting of 2 connecting cables to connect iPod/iPhone or data storage device/media player with USB port (type A); other adapter cables are available from Audi Genuine Accessories



### Rear Seat Entertainment

consists of 2 high-resolution adjustable-angle 10.2-inch LCD displays for the rear passengers; separate single DVD player in the rear compartment; 2 SDHC card readers, a dedicated jukebox with 20 GB of storage; Audi music interface with facility for connecting to an iPod, USB media (e.g. external hard disc), AUX-in and A/V-in (e.g. external video games consoles); supports audio formats (MP3, WMA and AAC-compatible) and video formats (MPEG-1, 2, 4, WMV and Xvid-compatible) as well as playlists; copy-protected music files (DRM) cannot be played. Use of navigation functions, e.g. navigation system display same as in MMI display, separate route planning and transfer of navigation information to MMI navigation plus with MMI touch is possible. Includes separate MMI control panel for the rear passengers, based on the proven MMI operating concept, with 2 separate volume controls incorporated into the rear centre armrest. Possible to have separate and shared video and audio sources for the left and right-hand seats; sound is output via the vehicle's sound system; possible to have wireless headphones (included in package) or wired headphones. 5.1 Surround Sound is supported if combined with the BOSE Surround Sound or the Bang & Advanced Sound System. Possible to access optional DVD/CD changer and TV tuner (analogue/digital)

## Telephone and communication

### Fitting for mobile phone (Bluetooth)

includes a hands-free facility (including voice control for the telephone functions) and a fitting for an optional mobile-specific charger (available from Audi Genuine Accessories) with a connection to the external aerial (via the base plate and adapter); operation via the MMI, the multifunction leather steering wheel or the speech dialogue system; for adapters and information on compatible mobile phones, please contact your Audi partner

### Bluetooth car phone online

a Bluetooth-capable mobile phone can be easily connected to the vehicle's internal UMTS module (provided the mobile phone has a SIM Access Profile), additional SIM card reader located in the surround of the MMI navigation plus. Audi online services also provide additional online functions: such as point of interest search, navigation with help of Google Earth images, convenient route planning and destination entry using MyAudi or Google Maps, information services e.g. weather and news, Audi traffic information online with traffic flow information for specific street sections on the navigation map, quick information on traffic tie-up development and resolution, greater coverage of the road network (e.g. national and rural roadways), WiFi hotspot for internet access for passengers in the rear passenger compartment using a mobile end device (e.g. laptop). Because of the high data volumes (currently concerns in particular navigation with the aid of Google Earth images and WiFi hotspot), a mobile phone contract including a data flat rate is strongly recommended! Online services are only available for mobile phone contracts including a data download option and only within the coverage of the mobile phone network; they are only offered in Europe (in Russia only in the Moscow and St. Petersburg areas; not in Turkey, Cyprus, Malta and Iceland); Additional costs arise for the use of these services (charges and billing correspond to your personal mobile phone contract); The content and scope of the online-based services offered may vary. Simple operation via the MMI navigation plus, a leather-covered multifunction steering wheel or the voice control system. (Can only be ordered in conjunction with MMI navigation plus or MMI touch)

## Telephone and communication



**Handset for Bluetooth car phone online, front** with colour display and integral SIM card reader, for making private calls; texts can be easily written thanks to automatic word recognition. (Can only be ordered in conjunction with MMI navigation plus with MMI touch and the Bluetooth car phone online)

### Handset for Bluetooth car phone online, front and rear

2 separate handsets with colour display and integral SIM card reader, for making private calls; texts can be easily written thanks to automatic word recognition, one each in the front and rear centre armrest. (Can only be ordered in conjunction with MMI navigation plus with MMI touch and the Bluetooth car phone online)

### Bluetooth interface, part of the MMI® navigation plus with MMI® touch

Bluetooth-compatible mobile phones can be connected to the vehicle via the interface; hands-free calls are possible in the vehicle via the microphone. (Can only be ordered in conjunction with MMI navigation plus or MMI touch).

## Assistance systems

### Audi pre sense basic

Networking the different vehicle systems enables driving situations to be categorised and, where necessary, actions to be implemented for preventive occupant protection. Such actions include seat belt tensioning, activation of the hazard warning lights and closing of sunroof and windows

### adaptive cruise control with Stop&Go function incl. Audi pre sense front

automatic distance control (control range 0–250 km/h); working within system limits, it uses 2 radar sensors and a camera to detect vehicles ahead and maintains the distance by automatic braking and accelerating; independent braking to a stop, automated restart at driver's request; 4 distance levels and 3 driving modes (comfort, dynamic and standard) can be selected individually. In addition to the functions of Audi pre sense basic, **Audi pre sense front** implements preventive occupant protection measures when threatened with an imminent frontal collision. Working within system limits, Audi pre sense front utilises the front sensors of the adaptive cruise control with Stop&Go function to carry out its detection tasks; includes Audi braking guard which observes the vehicle's surroundings and then warns the driver of any imminent threat of frontend collision with the vehicle ahead and implements preventative occupant protection measures. **Audi pre sense plus** is included if Audi side assist is also ordered. In addition to the functions of Audi pre sense front, Audi pre sense plus activates the Audi braking guard in certain situations when a collision is unavoidable and initiates a full braking action to minimise the severity of the crash as much as possible. (Can only be ordered in conjunction with parking system plus or parking system plus with reversing camera)

### Audi side assist including Audi pre sense rear

Lane change assistant; working within system limits, it assists the driver when changing lanes (operating range 30–250 km/h). Displays are incorporated into both exterior mirrors. Audi side assist uses 2 radar sensors to measure the vehicle's distance from other vehicles it has detected as well as the speed difference between them. If Audi side assist classifies the speed

difference and distance as being critical in the event of a lane change, a display will appear in the respective exterior mirror. In addition to the functions of Audi pre sense basic **Audi pre sense rear**, working within the system limits, uses the rear sensors of Audi side assist to detect a possible rear-end collision. If the vehicle is fitted with a seat memory function then the upper backrest and the head restraint are moved to a position more favourable should a rear-end collision occur. If comfort seats or comfort sports seats are fitted, the pneumatic seat bolsters are also filled with air. **Audi pre sense plus** is included if adaptive cruise control with Stop&Go function is also ordered. In addition to the functions of Audi pre sense front, Audi pre sense plus activates the Audi braking guard in certain situations when a collision is unavoidable and initiates a full braking action to minimise the severity of the crash as much as possible.

### Audi lane assist

lane compliance assistant; working within system limits, it informs the driver if he is unintentionally leaving the traffic lane (operating range 60–250 km/h). If the system is activated and operational and if the driver has not switched on the indicator, the driver will be notified via steering wheel vibrations shortly before or while crossing the traffic lane marker recognised by Audi lane assist. (Can only be ordered in conjunction with 4-spoke multifunction leather steering wheel)



### Night vision assistant with highlighting of detected pedestrians

with integral thermal imaging camera; when driving at night, this system extends the driver's range of visibility beyond the light provided by the dipped beam; records thermal images; an image processing algorithm then evaluates the camera's data and marks any persons it has detected in yellow in the driver information system's colour display; the marking changes to red and a warning tone is emitted if the system, by analysing the movement and position of the person it has detected, considers that there is a possible risk. Image quality is affected in poor ambient conditions

## Assistance systems

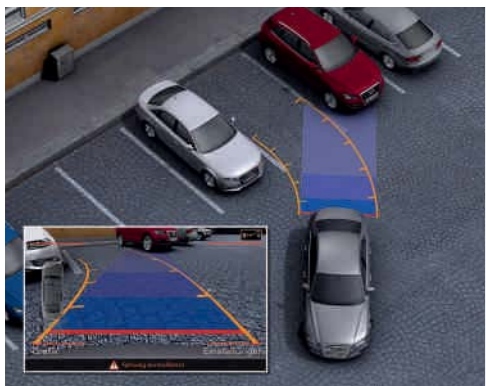
**Parking system plus with reversing camera**

acoustic and visual parking aid for front and rear, image of area behind the vehicle shown on the MMI display, with dynamic display modes showing the calculated path (steer-angle dependent); includes help lines and guidelines and identification of point at which to apply opposite lock when parallel parking, reversing camera concealed in the handle strip of the luggage compartment lid

**Parking system plus**

acoustic and visual park assist system for the front and rear with MMI screen display; measurement is by ultrasonic sensors concealed in the bumpers

**Speed limit display**

camera based recognition and display of speed limits, including temporary speed limit displays (e.g. above motorways). Additionally, within system limits, there is an evaluation of the particular situation in wet conditions, and speed limits displayed depending on the time of the day, road works and when using a trailer. If a sign has not been recognised by the camera the speed limit displayed will be taken from the navigation data (where available). (Can only be ordered in conjunction with adaptive cruise control with Stop&Go function and/or Audi lane assist)

**Cruise control**

maintains any speed above around 30 km/h, provided engine power output and engine braking effect permit; automatic braking function, e.g. when driving downhill; operated via separate steering column stalk

**Hold assist**

holds the vehicle stationary for unlimited periods after stopping on normal uphill and normal downhill gradients. The system is activated by push-button and allows the driver to drive away smoothly without having to operate the handbrake

## Suspension/brakes

**Audi drive select**

changes vehicle characteristics by, e.g., adapting power steering assistance, accelerator and gearshift characteristics and adaptive air suspension; modes available: comfort, auto, dynamic and individual. The system also influences other optional equipment

**Dynamic steering**

when changing lanes, parking and cornering, this system improves comfort and handling by dynamically regulating steering effort and steer angle according to the driving situation

**adaptive air suspension**

electronically controlled air suspension with infinitely variable adaptive damping system on all four wheels; automatically regulates vehicle ride height and damping; includes ride height control and manual lift function; different modes selected via Audi drive select

**adaptive air suspension sport**

sports suspension based on the standard-fitted adaptive air suspension; stiffer damping, vehicle ride height lowered by up to 10 mm depending on mode; different modes selected via Audi drive select

**Braking system**

with anti-lock brakes (ABS), electronic brake force distribution (EBD) and hydraulic brake assist, ventilated disc brakes front and rear, rear brakes with electromechanical parking brake

**Electromechanical parking brake**

with hold assist; includes parking brake function when stationary, drive-off assistance function by means of automatic release when driving away and emergency braking function whilst driving acting on all 4 wheels

## Technology/safety

**Body, Audi Space Frame (ASF)-construction**

innovative combination of materials, a high degree of rigidity for enhanced handling and greater stability

**Side impact protection**

consisting of bending-resistant door impact beams and reinforced body side structure, particularly in the B-pillars and sills

**Airbags**

2-stage deployment; front and rear side airbags incorporated into the seat backrests; the head airbag system unfolds along the entire length of the side windows as a protective cushion and protects the occupants in the front and outer rear seats in the event of a side impact

**Deactivation switch for front-passenger airbag****Integrated restraint system**

in the event of a rear-end collision, the design of the seat restrains the upper torso and supports the head at an early stage, thereby increasing safety and reducing the danger of whiplash

**Seat belts**

3-point inertia reel seat belts with reversible belt tensioners, adaptive belt force limiters and belt height adjustment/belt buckle status query at front; seat belt reminder function for driver and front-passenger seats with acoustic and visual warning signal

**Audi exclusive seat belts**

available in various Audi exclusive colours to match the Audi exclusive leather range of colours. From quattro GmbH

**Warning and indicator lamps**

in the instrument cluster for, among others: airbag, ABS, ESP/ASR, adaptive air suspension, activated electromechanical parking brake and cruise control, EDL electronics, main beam, indicators, rear fog lights, engine electronics and electronic accelerator

**First-aid kit**

in the storage compartment of the rear centre armrest

**Warning triangle**

with bracket on the inside of the luggage compartment lid

**Anti-lock braking system (ABS)**

with electronic brake-force distribution (EBD) and hydraulic brake assist

**Traction control (ASR)**

for good traction and lateral stability, reduces spinning of the drive wheels

**Electronic differential lock (EDL)**

on surfaces with varying levels of grip, this start-off assistant automatically brakes the drive wheels on the surface that is too slippery, thereby ensuring smooth, powerful progress

**Electronic Stabilization Programme (ESP)**

ensures greater stability in hazardous driving situations by targeted braking of individual wheels and intervention in the engine management system

**servotronic**

speed-dependent steering assistance; when parking, the vehicle can be easily steered without effort; at high speeds the steering system responds more directly and precisely, increases vehicle agility and responds more spontaneously to steering commands

**tiptronic**

8-speed automatic transmission with Dynamic Shift Program (DSP), option of manual control via shift paddles on the multifunction leather steering wheel; includes additional sports program

**quattro®**

permanent all-wheel drive with asymmetric/dynamic torque distribution, self-locking centre differential, electronic differential lock (EDL) via braking intervention on all driven wheels

**quattro® with sports differential**

The electronically controlled sports differential distributes the drive forces variably between the rear wheels. The sports differential can provide different amounts of torque to each rear wheel, ensures outstanding acceleration performance in corners and stabilises the vehicle's response to load change. It also ensures better direct steering characteristics and, thanks to less steering effort, more agile handling

**Misfuelling protection**

mechanical device to prevent refuelling of diesel vehicles with petrol

**Recuperation**

Increasing the generator voltage converts kinetic energy into usable electrical energy when the vehicle is coasting or braking. This energy is used to assist the generator during subsequent acceleration, thereby making fuel savings of up to 3%

**Start/stop system**

reduces fuel consumption and CO<sub>2</sub> emissions by switching off the engine when the vehicle is stationary, e.g. at traffic lights. The start process is initiated as soon as the foot brake is released for a perfect getaway. Can be deactivated at any time via the switch

## Audi extended warranty

**Audi extended warranty**

can only be ordered directly and on purchase of a new car; is a consistent continuation of the manufacturer's guarantee so that you are protected against risk and can control servicing costs even after the first 2 years. There is a total of 9 lifetime/total mileage combinations to choose from:

1 additional year under Audi extended warranty, maximum total mileage of 30,000 km

1 additional year under Audi extended warranty, maximum total mileage of 60,000 km

1 additional year under Audi extended warranty, maximum total mileage of 90,000 km

2 additional years under Audi extended warranty, maximum total mileage of 40,000 km

2 additional years under Audi extended warranty, maximum total mileage of 80,000 km

2 additional years under Audi extended warranty, maximum total mileage of 120,000 km

3 additional years under Audi extended warranty, maximum total mileage of 50,000 km

3 additional years under Audi extended warranty, maximum total mileage of 100,000 km

3 additional years under Audi extended warranty, maximum total mileage of 150,000 km

## Audi Top Service®.



### Mobility guarantee<sup>1</sup>

You will receive free assistance as quickly as possible if your Audi should break down. The mobility guarantee is initially valid for 2 years and is renewed every time you have an inspection carried out by an Audi partner or whenever you get your vehicle serviced in accordance with the service interval display in the instrument cluster. For more information, please contact your Audi partner.

### Pick-up and delivery service

Pick-up and delivery service for workshop appointments. Your vehicle will be picked up and returned to you by your Audi partner. Prices and conditions vary depending on the distance from the dealership. For more information, please contact your Audi partner.

### Round-the-clock assistance

We are there to help in the event of a breakdown.<sup>2</sup> For more information and the telephone number for your country, please contact your Audi partner.

### Audi extended warranty<sup>3</sup>

When purchasing a new vehicle, a 100% Audi manufacturer's guarantee can be easily included in the order so that, even after the two-year guarantee period has expired you are protected against risk and can control costs. The Audi extended warranty offers you an individual combination of service life and mileage for up to 3 years following the end of the manufacturer's guarantee with a maximum mileage of 150,000 km.

### Audi Genuine Parts®

Audi Genuine Parts are tailored to the respective Audi model to ensure a perfect fit. Development to production-level standards and extensive testing ensure they not only do the job but also meet exacting requirements in terms of long service life and quality.

In motorsport, what counts is a well-rehearsed team, know-how and precision. You can expect the same from Audi Service: whether for maintenance, servicing or for professional repair of accident damage. And unlike a pit-stop, we are not available for just a few seconds, we are there for you 24 hours a day.

Moreover, your Audi partner offers you an extended warranty if you purchase a new car.

<sup>1</sup> Please ask your Audi Partner whether the mobility guarantee is available in your country.

<sup>2</sup> Please ask your Audi Partner whether the hotline is available free in your country.

<sup>3</sup> Your Audi partner will be happy to inform you if the Audi extended warranty is available in your country.

Find out from your local Audi partner which service is free of charge or available at an additional cost in your country.

## Audi Genuine Accessories: Your Audi should be different.



You are a person who's interested in new trends and styles. And in an Audi. Both complement each other perfectly. Because Audi Genuine Accessories offer you the opportunity to make your car even more individual. With high-quality products that are exactly tailored to your vehicle. So that an Audi is transformed into your own personal Audi. The following pages contain a small selection from the extensive range of Audi Genuine Accessories on offer.

Detailed information can be obtained from the Audi A8 accessories catalogue, at [www.audi.com](http://www.audi.com), and from your Audi partner.



# A8

Audi A8 Accessories



**1 Cast aluminium winter wheels, 7-arm design<sup>1</sup>**  
Classic complete winter wheel, size 7.5 J x 17 with 235/60 R 17 tyres.

**2 Ski and luggage box (480 l)**  
Ski box for winter sports equipment and other luggage. Lockable and can be opened from both sides. Easy-to-clean thanks to smooth surface. Also available with a capacity of 450 l or as a compact luggage box with a capacity of 370 l. Maximum permissible load 50 kg. (Can only be used in conjunction with a carrier unit available from Audi Genuine Accessories.)

**Cast aluminium wheels in 5-arm parabola design<sup>1</sup>**  
Exceptional design, perfectly matched to your A8. With high-gloss turned arms, size 9 J x 20. Tyre size 265/40 R 20.

**3 Adapter cables for Audi music interface**  
Enable connection of various iPod models and other portable media players. Operation via the MMI system if the function is supported by the media player. Additional adapter cables are required to connect portable media players; further information is available from your Audi partner.

**4 Audi child seat youngster**  
Offers superior comfort thanks to intelligent belt guidance. Adaptations can be made via a viewing window for size adjustment. Suitable for children from 15 to 36 kg (approximately 3½ to 12 years). Also available: The Audi baby seat suitable for small children up to 13 kg and the Audi child seat with ISOFIX for children from 9 to 18 kg.

**5 Audi Tracking Assistant and Audi Tracking Assistant plus<sup>1, 2</sup>**  
Enable a stolen vehicle to be located and tracked via GPS/GSM technology in 27 European countries. Available in two variants. Audi Tracking Assistant plus with automatic driver recognition and intelligent restart inhibitor.

<sup>1</sup>For information on when this feature will be available, please contact your Audi partner. <sup>2</sup>For more detailed information, please contact your Audi partner.



Model	A8 3.0 TFSI quattro	A8 3.0 TDI quattro	A8 4.2 FSI quattro	A8 4.2 TDI quattro
Engine type	V6-cylinder petrol engine with direct fuel injection and mechanical charging module	V6-cylinder diesel engine with common rail injection system and exhaust-gas turbocharging	V8-cylinder petrol engine with direct fuel injection	V8-cylinder diesel engine with common rail injection system and exhaust-gas turbocharger
Displacement in cc (valves per cylinder)	2995 (4)	2967 (4)	4163 (4)	4134 (4)
Max. output <sup>1</sup> in kW at rpm	213/4850–6500	184/4000–4500	273/6800	258/4000
Max. torque in Nm at rpm	420/2500–4850	550/1500–3000	445/3500	800/1750–2750
Power transmission/wheels				
Type of drive	quattro® permanent all-wheel drive	quattro® permanent all-wheel drive	quattro® permanent all-wheel drive	quattro® permanent all-wheel drive
Transmission	8-speed tiptronic	8-speed tiptronic	8-speed tiptronic	8-speed tiptronic
Wheels	Forged aluminium wheels, 8 J x 17	Forged aluminium wheels, 8 J x 17	Forged aluminium wheels, 8 J x 17	Cast aluminium wheels, 8 J x 18
Tyres	235/60 R 17	235/60 R 17	235/60 R 17	235/55 R 18
Weights/capacities				
Unladen weight <sup>2</sup> in kg	<b>A8</b> <p>1905</p> <b>A8 L</b> <p>1955</p>	<b>A8</b> <p>1915</p> <b>A8 L</b> <p>1965</p>	<b>A8</b> <p>1910</p> <b>A8 L</b> <p>1960</p>	<b>A8</b> <p>2070</p> <b>A8 L</b> <p>2120</p>
Gross vehicle weight in kg	2520	2530	2530	2660
Roof load/trailer nose weight in kg	100/95	100/95	100/95	100/95
Trailer load limit <sup>3</sup> in kg	unbraked <p>12<span> </span>% gradient</p> <p>8<span> </span>% gradient</p>	750 <p>2300</p> <p>2300</p>	750 <p>2200</p> <p>2200</p>	750 <p>2300</p> <p>2300</p>
Fuel tank capacity, approx., in l	90	90	90	90
Performance/consumption <sup>4</sup>				
Top speed in km/h	250 <sup>5</sup>	250 <sup>5</sup>	250 <sup>5</sup>	250 <sup>5</sup>
Acceleration 0–100 km/h in s	6.1	6.2	6.1	5.7
Fuel grade	Sulphur-free super unleaded 95 RON <sup>6</sup>	Sulphur-free diesel <sup>7</sup>	Sulphur-free super unleaded 95 RON <sup>6</sup>	Sulphur-free diesel <sup>7</sup>
Fuel consumption <sup>8</sup> in l/100 km	urban <p>extra-urban</p> <p>combined</p>	12.9 <p>13.1</p> <p>6.9</p> <p>7.1</p> <p>9.1</p> <p>9.3</p>	8.0 <p>8.0</p> <p>5.8</p> <p>5.8</p> <p>6.6</p> <p>6.6</p>	13.3 <p>13.6</p> <p>7.2</p> <p>7.4</p> <p>9.5</p> <p>9.7</p>
CO <sub>2</sub> emissions <sup>8</sup> in g/km	urban <p>extra-urban</p> <p>combined</p>	300 <p>162</p> <p>213</p>	305 <p>165</p> <p>217</p>	211 <p>153</p> <p>174</p>
Emissions standard	EU5	EU5	EU5	EU5

Model	A8 L W12 quattro
Engine type	W12-cylinder petrol engine
Displacement in cc (valves per cylinder)	6299 (4)
Max. output <sup>1</sup> in kW at rpm	368/6200
Max. torque in Nm at rpm	625/4750
Power transmission/wheels	
Type of drive	quattro® permanent all-wheel drive
Transmission	8-speed tiptronic
Wheels	Cast aluminium wheels, 9 J x 19
Tyres	255/45 R 19
Weights/capacities	
Unladen weight <sup>2</sup> in kg	2130
Gross vehicle weight in kg	2655
Roof load/trailer nose weight in kg	100/95
Trailer load limit <sup>3</sup> in kg	unbraked <p>12<span> </span>% gradient</p> <p>8<span> </span>% gradient</p>
Fuel tank capacity, approx., in l	90
Performance/consumption <sup>4</sup>	
Top speed in km/h	250 <sup>5</sup>
Acceleration 0–100 km/h in s	4.7
Fuel grade	Sulphur-free super unleaded 95 RON <sup>6</sup>
Fuel consumption <sup>8</sup> in l/100 km	urban <p>extra-urban</p> <p>combined</p>
CO <sub>2</sub> emissions <sup>8</sup> in g/km	urban <p>extra-urban</p> <p>combined</p>
Emissions standard	EU5

#### Notes

<sup>1</sup> The figure stated was calculated using the specified measuring procedure (current version of Directive 80/1269/EEC).

<sup>2</sup> Weight of car, unladen, with driver (68 kg), luggage (7 kg) and fuel tank 90 % full, calculated in accordance with the current version of Directive 92/21/EEC. Optional equipment may increase the car's unladen weight and drag coefficient, whereupon the possible payload limit and the top speed will be reduced accordingly.

<sup>3</sup> The engine's power output always goes down with increasing altitude. At 1,000 m above sea level, and for every additional 1,000 m, deduct 10 % from the weight of the outfit (trailer load limit + gross weight of the towing vehicle). Figure for trailer load limit applies to factory-fitted trailer towing hitch. If using the vehicle with a trailer towing hitch for commercial purposes, a digital tachograph may be required under certain conditions.

<sup>4</sup> A vehicle's fuel consumption and CO<sub>2</sub> emissions do not just depend on how efficiently the vehicle uses the fuel, but are also influenced by driving behaviour and other non-technical factors. CO<sub>2</sub> is the greenhouse gas primarily responsible for global warming.

<sup>5</sup> Regulated.

<sup>6</sup> We recommend using sulphur-free super unleaded RON 95 in accordance with DIN EN 228. If this is not available, use sulphur-free regular unleaded 91 RON fuel complying with DIN EN 228; power output will be slightly reduced. Unleaded RON 95 fuel with a maximum ethanol content of 10 % (E10) can generally be used. Fuel consumption details refer to operation with RON 95 fuel in accordance with 692/2008/EC.

<sup>7</sup> We recommend using sulphur-free diesel in accordance with DIN EN 590. If this is not available, use diesel in accordance with DIN EN 590.

<sup>8</sup> The figures given were calculated using the specified measuring procedures. The figures do not refer to one individual vehicle and do not form part of any offer, but rather should be used purely for purposes of comparison between the different vehicle models.

#### Important note

Inspections are due as shown by the service display.

## Audi A8

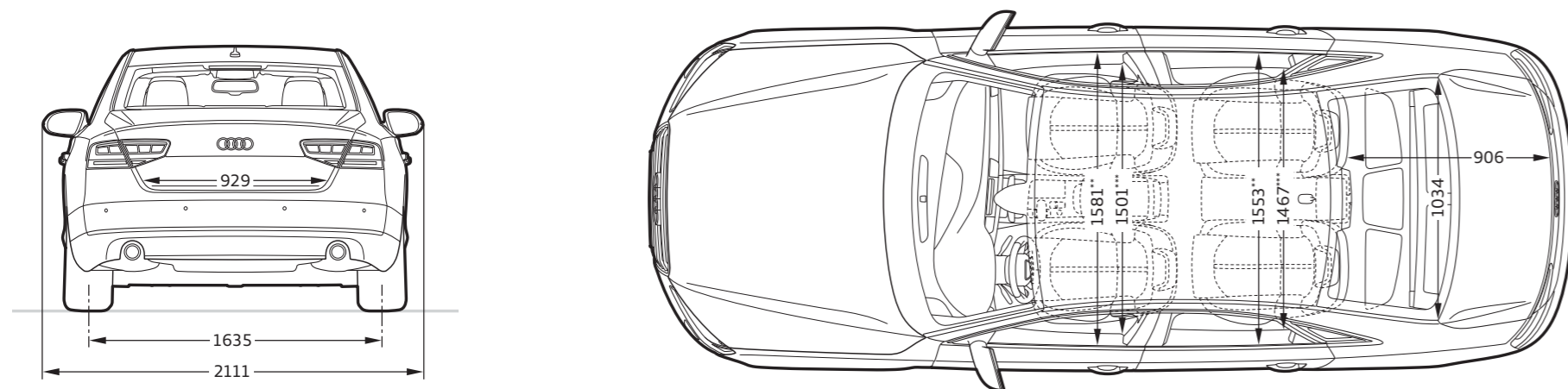
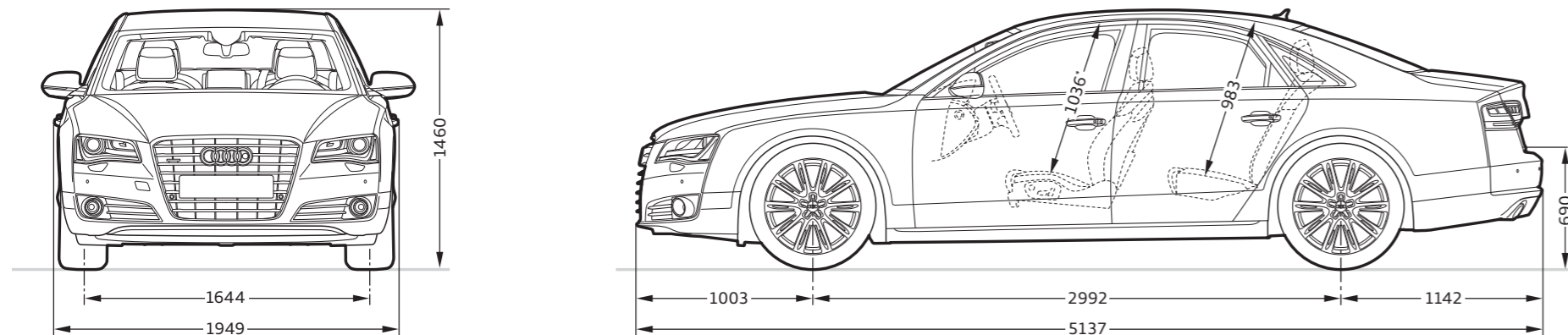
**Dimensions in millimetres.**

Dimensions were measured with vehicle at unladen weight, ground clearance measured with vehicle carrying its maximum load.

Luggage compartment volume in l: 510 (measured by the VDA method using 200 x 100 x 50 mm blocks).

Turning circle approx. 12.3 m. \*Maximum headroom. \*\*Elbow room width. \*\*\*Shoulder room width.

## Audi A8 L/A8 L W12

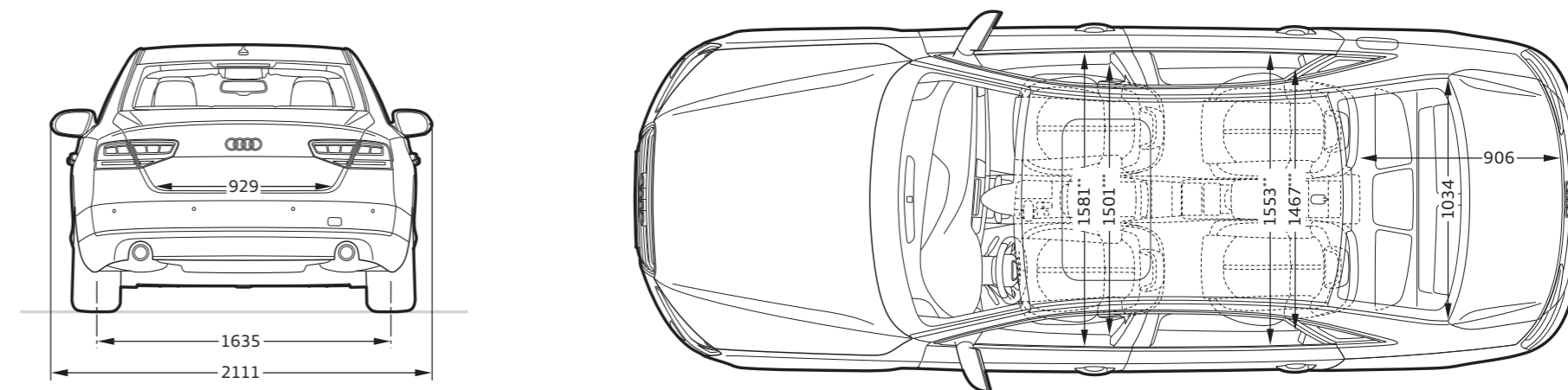
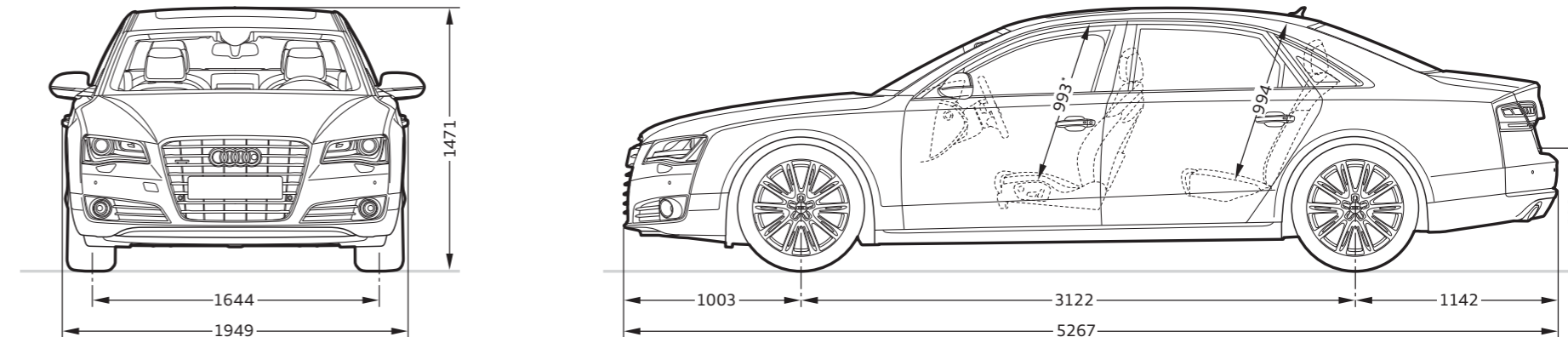
**Dimensions in millimetres.**

Dimensions were measured with vehicle at unladen weight, ground clearance measured with vehicle carrying its maximum load.

Luggage compartment volume in l: 510 (measured by the VDA method using 200 x 100 x 50 mm blocks).

Turning circle approx. 12.7 m. \*Maximum headroom. \*\*Elbow room width. \*\*\*Shoulder room width.

## At Audi, you get much more than an Audi.

Anyone who chooses an Audi chooses a brand that offers its customers more. More individuality. More exclusivity. And more fascination.



### www.audi.com

Vorsprung durch Technik, and everything that it entails: the legendary Audi history, dates of unforgettable events and ground-breaking innovations – let your fascination grow with the Audi brand.  
> [www.audi.com](http://www.audi.com)

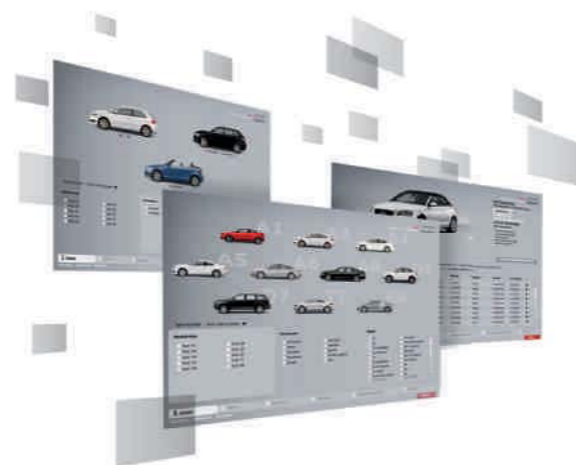

### Audi configurator

Create your own personal Audi using the Audi configurator. All current models, engines, colours and equipment options are available for you to choose from.  
> [www.audi.com](http://www.audi.com)

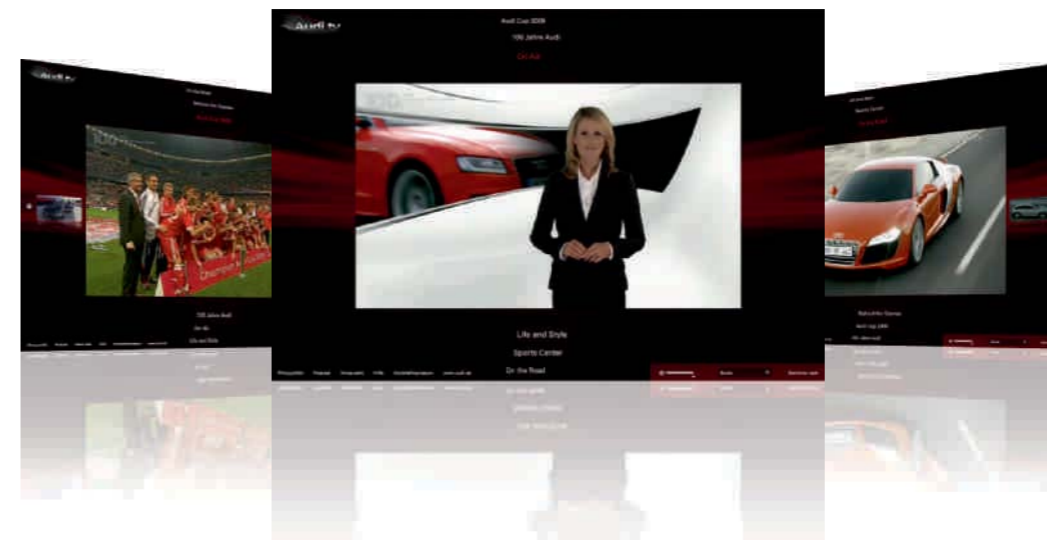

### Audi tv

On Audi tv you can discover new facets of our brand with the four rings: exciting commentaries on our models, technical innovations, fascinating events from the fields of motorsport, tradition, culture and lifestyle. Take a look behind the scenes. The latest news every day. Round the clock.  
> [www.audi.tv](http://www.audi.tv)



### Audi Bank

Financing. Leasing. Insuring. Whichever new Audi you decide on, every quotation from the Audi Bank is individually tailored to you. Our special offer packages, for example, combine current financing and leasing options with comprehensive insurance protection and thus offer you unlimited mobility.  
> [www.audi.com](http://www.audi.com)

	Page	A8	A8 L	A8 L W12
<b>Paint finishes</b>	<b>78</b>			
Brilliant Black		<input type="checkbox"/>	<input type="checkbox"/>	<input type="checkbox"/>
Ibis White		<input type="checkbox"/>	<input type="checkbox"/>	<input type="checkbox"/>
Havana Black, metallic		<input checked="" type="checkbox"/>	<input checked="" type="checkbox"/>	<input checked="" type="checkbox"/>
Emerald Black, metallic		<input checked="" type="checkbox"/>	<input checked="" type="checkbox"/>	<input checked="" type="checkbox"/>
Oolong Grey, metallic		<input checked="" type="checkbox"/>	<input checked="" type="checkbox"/>	<input checked="" type="checkbox"/>
Quartz Grey, metallic		<input checked="" type="checkbox"/>	<input checked="" type="checkbox"/>	<input checked="" type="checkbox"/>
Ice Silver, metallic		<input checked="" type="checkbox"/>	<input checked="" type="checkbox"/>	<input checked="" type="checkbox"/>
Glacier White, metallic		<input checked="" type="checkbox"/>	<input checked="" type="checkbox"/>	<input checked="" type="checkbox"/>
Phantom Black, pearl effect		<input checked="" type="checkbox"/>	<input checked="" type="checkbox"/>	<input checked="" type="checkbox"/>
Night Blue, pearl effect		<input checked="" type="checkbox"/>	<input checked="" type="checkbox"/>	<input checked="" type="checkbox"/>
Impala Beige, pearl effect		<input checked="" type="checkbox"/>	<input checked="" type="checkbox"/>	<input checked="" type="checkbox"/>
Audi exclusive individual paint finishes		<input checked="" type="checkbox"/>	<input checked="" type="checkbox"/>	<input checked="" type="checkbox"/>
<b>Seats/seat covers</b>	<b>80</b>			
Standard seats, front		<input type="checkbox"/>	<input type="checkbox"/>	–
Standard seats, front with/without seat ventilation		<input checked="" type="checkbox"/>	<input checked="" type="checkbox"/>	<input checked="" type="checkbox"/>
Comfort seats, front		<input checked="" type="checkbox"/>	<input checked="" type="checkbox"/>	<input type="checkbox"/>
Front comfort seats with optional seat ventilation		<input checked="" type="checkbox"/>	<input checked="" type="checkbox"/>	<input checked="" type="checkbox"/>
Verdi cloth		<input type="checkbox"/>	<input type="checkbox"/>	–
Alcantara/Leather combination		<input checked="" type="checkbox"/>	<input checked="" type="checkbox"/>	<input checked="" type="checkbox"/>
Valcona leather		<input checked="" type="checkbox"/>	<input checked="" type="checkbox"/>	<input type="checkbox"/>
Natural leather		<input checked="" type="checkbox"/>	<input checked="" type="checkbox"/>	<input checked="" type="checkbox"/>
Valonea leather		<input checked="" type="checkbox"/>	<input checked="" type="checkbox"/>	<input checked="" type="checkbox"/>
Audi exclusive leather upholstery and trim		<input checked="" type="checkbox"/>	<input checked="" type="checkbox"/>	<input checked="" type="checkbox"/>
Leather package		<input checked="" type="checkbox"/>	<input checked="" type="checkbox"/>	–
Extended leather package		<input checked="" type="checkbox"/>	<input checked="" type="checkbox"/>	<input type="checkbox"/>

	Page	A8	A8 L	A8 L W12
Full-leather package		<input checked="" type="checkbox"/>	<input checked="" type="checkbox"/>	<input checked="" type="checkbox"/>
Audi exclusive leather upholstery and trim (package 1)		<input checked="" type="checkbox"/>	<input checked="" type="checkbox"/>	<input checked="" type="checkbox"/>
Audi exclusive leather upholstery and trim (package 2)		<input checked="" type="checkbox"/>	<input checked="" type="checkbox"/>	<input checked="" type="checkbox"/>
Audi exclusive leather upholstery and trim (package 3)		<input checked="" type="checkbox"/>	<input checked="" type="checkbox"/>	<input checked="" type="checkbox"/>
Audi exclusive leather upholstery and trim (package 4)		<input checked="" type="checkbox"/>	<input checked="" type="checkbox"/>	<input checked="" type="checkbox"/>
Audi design selection balao brown		<input checked="" type="checkbox"/>	<input checked="" type="checkbox"/>	<input checked="" type="checkbox"/>
Audi design selection brass beige		<input checked="" type="checkbox"/>	<input checked="" type="checkbox"/>	<input checked="" type="checkbox"/>
<b>Headlining</b>	<b>87</b>			
Headlining in Alcantara		<input checked="" type="checkbox"/>	<input checked="" type="checkbox"/>	<input type="checkbox"/>
Headlining in cloth		<input type="checkbox"/>	<input type="checkbox"/>	–
Audi exclusive headlining in Alcantara		<input checked="" type="checkbox"/>	<input checked="" type="checkbox"/>	<input checked="" type="checkbox"/>
Audi exclusive parcel shelf in Alcantara		<input checked="" type="checkbox"/>	<input checked="" type="checkbox"/>	<input checked="" type="checkbox"/>
<b>Inlays (upper/lower inlay)</b>	<b>88</b>			
Walnut tree root wood brown/high gloss black		<input type="checkbox"/>	<input type="checkbox"/>	–
Fine grain birch wood pearl beige/high gloss black		<input checked="" type="checkbox"/>	<input checked="" type="checkbox"/>	–
Fine grain ash velvet brown/high gloss black		<input checked="" type="checkbox"/>	<input checked="" type="checkbox"/>	–
Vavona wood assam grey/high gloss black		<input checked="" type="checkbox"/>	<input checked="" type="checkbox"/>	–
Walnut tree root wood brown/brushed aluminium silver		<input checked="" type="checkbox"/>	<input checked="" type="checkbox"/>	<input checked="" type="checkbox"/>
Fine grain birch wood pearl beige/brushed aluminium silver		<input checked="" type="checkbox"/>	<input checked="" type="checkbox"/>	<input checked="" type="checkbox"/>
Fine grain ash velvet brown/brushed aluminium silver		<input checked="" type="checkbox"/>	<input checked="" type="checkbox"/>	<input checked="" type="checkbox"/>
Vavona wood assam grey/brushed aluminium silver		<input checked="" type="checkbox"/>	<input checked="" type="checkbox"/>	<input checked="" type="checkbox"/>
Fine grain ash natural balsamic brown/brushed aluminium silver		<input checked="" type="checkbox"/>	<input checked="" type="checkbox"/>	<input checked="" type="checkbox"/>
Piano finish black/brushed aluminium silver		–	–	<input type="checkbox"/>
Audi exclusive inlays		<input checked="" type="checkbox"/>	<input checked="" type="checkbox"/>	<input checked="" type="checkbox"/>
Aluminium look on the interior		<input type="checkbox"/>	<input type="checkbox"/>	<input type="checkbox"/>
Extended aluminium look on the interior		<input checked="" type="checkbox"/>	<input checked="" type="checkbox"/>	<input type="checkbox"/>

	Page	A8	A8 L	A8 L W12
<b>Wheels/tyres</b>	<b>90</b>			
Forged aluminium wheels in 6-arm design		<input type="checkbox"/> <sup>1</sup>	<input type="checkbox"/> <sup>1</sup>	–
Cast aluminium wheels in 7-arm design		<input type="checkbox"/> <sup>2</sup>	<input type="checkbox"/> <sup>2</sup>	–
Forged aluminium winter wheels in 6-arm design		<input checked="" type="checkbox"/>	<input checked="" type="checkbox"/>	–
Cast aluminium winter wheels in 7-arm design		<input checked="" type="checkbox"/>	<input checked="" type="checkbox"/>	–
Cast aluminium wheels in 10-spoke Y design, partially polished		<input checked="" type="checkbox"/>	<input checked="" type="checkbox"/>	<input checked="" type="checkbox"/>
Cast aluminium wheels in 5-arm design		<input checked="" type="checkbox"/>	<input checked="" type="checkbox"/>	<input checked="" type="checkbox"/>
Forged aluminium wheels in 10-parallel-spoke design, partially polished		<input checked="" type="checkbox"/>	<input checked="" type="checkbox"/>	<input checked="" type="checkbox"/>
Audi exclusive cast aluminium wheels in 5-double-spoke design		<input checked="" type="checkbox"/>	<input checked="" type="checkbox"/>	<input checked="" type="checkbox"/>
Forged aluminium wheels Audi exclusive in 7-double-spoke design, polished, two-tone		<input checked="" type="checkbox"/>	<input checked="" type="checkbox"/>	<input checked="" type="checkbox"/>
Forged aluminium wheels Audi exclusive in 7-double-spoke design, high-gloss polished finish, single colour		<input checked="" type="checkbox"/>	<input checked="" type="checkbox"/>	<input checked="" type="checkbox"/>
Audi exclusive cast aluminium wheels in 5-segment spoke design		<input checked="" type="checkbox"/>	<input checked="" type="checkbox"/>	<input checked="" type="checkbox"/>
Audi exclusive cast aluminium wheels in 5-arm rotor design		<input checked="" type="checkbox"/>	<input checked="" type="checkbox"/>	<input checked="" type="checkbox"/>
Audi exclusive cast aluminium wheels in 5-arm rotor design, titanium look, high-gloss turned finish		<input checked="" type="checkbox"/>	<input checked="" type="checkbox"/>	<input checked="" type="checkbox"/>
Audi exclusive cast aluminium wheels in 5-arm structure design		<input checked="" type="checkbox"/>	<input checked="" type="checkbox"/>	<input checked="" type="checkbox"/>
Cast aluminium winter wheels in 5-arm design		<input checked="" type="checkbox"/>	<input checked="" type="checkbox"/>	<input checked="" type="checkbox"/>
Forged aluminium winter wheels in 10-parallel spoke design		<input checked="" type="checkbox"/>	<input checked="" type="checkbox"/>	<input checked="" type="checkbox"/>
Cast aluminium wheels in 15-spoke design, partially polished		–	–	<input type="checkbox"/>
Run-flat tyres		<input checked="" type="checkbox"/>	<input checked="" type="checkbox"/>	<input checked="" type="checkbox"/>
Wheel bolts, anti-theft		<input checked="" type="checkbox"/>	<input checked="" type="checkbox"/>	<input checked="" type="checkbox"/>
Tyre repair kit		<input type="checkbox"/>	<input type="checkbox"/>	<input type="checkbox"/>
Spare wheel, space-saving		<input checked="" type="checkbox"/>	<input checked="" type="checkbox"/>	<input checked="" type="checkbox"/>
Tyre pressure monitoring system		<input type="checkbox"/>	<input type="checkbox"/>	<input type="checkbox"/>
Vehicle tool kit		<input type="checkbox"/>	<input type="checkbox"/>	<input type="checkbox"/>
Jack		<input type="checkbox"/>	<input type="checkbox"/>	<input type="checkbox"/>

	Page	A8	A8 L	A8 L W12
<b>Lights</b>	<b>92</b>			
LED headlights		<input checked="" type="checkbox"/>	<input checked="" type="checkbox"/>	<input type="checkbox"/>
adaptive light		<input checked="" type="checkbox"/>	<input checked="" type="checkbox"/>	–
adaptive light including variable beam angle adjustment		<input checked="" type="checkbox"/>	<input checked="" type="checkbox"/>	–
xenon plus including headlight cleaning system		<input type="checkbox"/>	<input type="checkbox"/>	–
Light/rain sensor		<input type="checkbox"/>	<input type="checkbox"/>	<input type="checkbox"/>
Interior and exterior lighting package		<input type="checkbox"/>	<input type="checkbox"/>	<input type="checkbox"/>
Ambient lighting		<input checked="" type="checkbox"/>	<input checked="" type="checkbox"/>	<input type="checkbox"/>
adaptive brake light		<input type="checkbox"/>	<input type="checkbox"/>	<input type="checkbox"/>
LED rear lights		<input type="checkbox"/>	<input type="checkbox"/>	<input type="checkbox"/>
Additional reading lights in the rear		<input checked="" type="checkbox"/>	–	–
Make up mirrors and additional reading lights in the rear		–	<input type="checkbox"/>	<input type="checkbox"/>
<b>Mirrors</b>	<b>93</b>			
Exterior mirrors with integral LED indicators		<input type="checkbox"/>	<input type="checkbox"/>	<input type="checkbox"/>
Exterior mirrors, electrically adjustable, heated and folding, automatically dimming on both sides		<input checked="" type="checkbox"/>	<input checked="" type="checkbox"/>	–
Exterior mirrors, electrically adjustable, heated and folding, automatically dimming on both sides with memory function		<input checked="" type="checkbox"/>	<input checked="" type="checkbox"/>	<input type="checkbox"/>
Interior mirror, automatically dimming		<input type="checkbox"/>	<input type="checkbox"/>	<input type="checkbox"/>
<b>Roof systems</b>	<b>94</b>			
Glass tilt/slide sunroof		<input checked="" type="checkbox"/>	<input type="checkbox"/>	<input type="checkbox"/>
Solar tilt/slide sunroof		<input checked="" type="checkbox"/>	<input checked="" type="checkbox"/>	<input checked="" type="checkbox"/>
Panoramic glass roof		–	<input checked="" type="checkbox"/>	<input checked="" type="checkbox"/>

Standard equipment    Optional equipment    Standard-/optional equipment varies by model   – not available

Country-specific variations possible. Please find out from your local Audi partner which equipment is standard and what optional equipment is available in your country.

<sup>1</sup>Standard on 3.0 TDI quattro, 3.0 TFSI quattro and 4.2 FSI quattro.   <sup>2</sup>Standard on 4.2 TDI quattro

	Page	A8	A8 L	A8 L W12
<b>Closing systems</b>	<b>95</b>			
Engine start-stop button		<input type="checkbox"/>	<input type="checkbox"/>	<input type="checkbox"/>
Convenience key		<input checked="" type="checkbox"/>	<input checked="" type="checkbox"/>	<input type="checkbox"/>
Power-assisted closing for the doors		<input checked="" type="checkbox"/>	<input checked="" type="checkbox"/>	<input type="checkbox"/>
Power-assisted closing for the luggage compartment lid		<input type="checkbox"/>	<input type="checkbox"/>	–
Luggage compartment lid, automatically opening		<input checked="" type="checkbox"/>	<input checked="" type="checkbox"/>	–
Luggage compartment lid, electrically opening and closing		<input checked="" type="checkbox"/>	<input checked="" type="checkbox"/>	<input type="checkbox"/>
Garage door opener (Homelink)		<input checked="" type="checkbox"/>	<input checked="" type="checkbox"/>	<input checked="" type="checkbox"/>
Anti-theft alarm		<input type="checkbox"/>	<input type="checkbox"/>	<input type="checkbox"/>
Fitting for Tracking Assistant		<input checked="" type="checkbox"/>	<input checked="" type="checkbox"/>	<input checked="" type="checkbox"/>
<b>Glazing</b>	<b>95</b>			
Heat-insulating glass		<input type="checkbox"/>	<input type="checkbox"/>	–
Double/acoustic glazing		<input checked="" type="checkbox"/>	<input checked="" type="checkbox"/>	<input checked="" type="checkbox"/>
Insulating/acoustic glass		<input checked="" type="checkbox"/>	<input checked="" type="checkbox"/>	<input type="checkbox"/>
Insulating/acoustic glass with windscreen heater		<input checked="" type="checkbox"/>	<input checked="" type="checkbox"/>	<input checked="" type="checkbox"/>
Dark-tinted windows (privacy glazing)		<input checked="" type="checkbox"/>	<input checked="" type="checkbox"/>	<input checked="" type="checkbox"/>
Sun blinds, electrically adjustable for the rear window		<input checked="" type="checkbox"/>	–	–
Sun blinds, electrically adjustable for the rear window and for the rear door windows		<input checked="" type="checkbox"/>	<input type="checkbox"/>	<input type="checkbox"/>
<b>Further exterior equipment</b>	<b>96</b>			
Provision for trailer towing hitch		<input checked="" type="checkbox"/>	<input checked="" type="checkbox"/>	<input checked="" type="checkbox"/>
Trailer towing hitch		<input checked="" type="checkbox"/>	<input checked="" type="checkbox"/>	<input checked="" type="checkbox"/>
Exhaust tailpipes		<input type="checkbox"/>	<input type="checkbox"/>	<input type="checkbox"/>
Model name/logo		<input type="checkbox"/>	<input type="checkbox"/>	<input type="checkbox"/>
W12 logo		–	–	<input type="checkbox"/>

	Page	A8	A8 L	A8 L W12
<b>Seats/seating comfort</b>	<b>96</b>			
Rear seat system		<input type="checkbox"/>	<input type="checkbox"/>	<input checked="" type="checkbox"/>
Individual rear seats, electrically adjustable		<input checked="" type="checkbox"/>	<input checked="" type="checkbox"/>	<input type="checkbox"/>
Memory function for standard seats		<input checked="" type="checkbox"/>	<input checked="" type="checkbox"/>	–
Individual rear seats, electrically adjustable, with full length, leather trimmed centre console		–	<input checked="" type="checkbox"/>	<input checked="" type="checkbox"/>
Relaxation seat		–	<input checked="" type="checkbox"/>	<input checked="" type="checkbox"/>
Massage function, front		<input checked="" type="checkbox"/>	<input checked="" type="checkbox"/>	<input checked="" type="checkbox"/>
Massage function, front and rear		<input checked="" type="checkbox"/>	<input checked="" type="checkbox"/>	<input checked="" type="checkbox"/>
Seat ventilation, front		<input checked="" type="checkbox"/>	<input checked="" type="checkbox"/>	<input checked="" type="checkbox"/>
Seat ventilation, front and rear		<input checked="" type="checkbox"/>	<input checked="" type="checkbox"/>	<input checked="" type="checkbox"/>
Centre armrest, front		<input type="checkbox"/>	<input type="checkbox"/>	–
Comfort centre armrest, front		<input checked="" type="checkbox"/>	<input checked="" type="checkbox"/>	<input type="checkbox"/>
Centre armrest, rear		<input type="checkbox"/>	<input type="checkbox"/>	<input type="checkbox"/>
Grab handles with wooden segments		<input checked="" type="checkbox"/>	<input checked="" type="checkbox"/>	<input type="checkbox"/>
Comfort head restraints, rear		<input checked="" type="checkbox"/>	<input checked="" type="checkbox"/>	<input type="checkbox"/>
ISOFIX child seat mountings for the two outer rear seats		<input type="checkbox"/>	<input type="checkbox"/>	<input type="checkbox"/>
Seat heaters, front		<input checked="" type="checkbox"/>	<input checked="" type="checkbox"/>	–
Seat heaters, front and rear		<input checked="" type="checkbox"/>	<input checked="" type="checkbox"/>	<input type="checkbox"/>
Foot rests at the rear		–	<input checked="" type="checkbox"/>	<input checked="" type="checkbox"/>
Audi exclusive rear foot rests		–	<input checked="" type="checkbox"/>	<input checked="" type="checkbox"/>

	Page	A8	A8 L	A8 L W12
<b>Steering wheels/selector levers/controls</b>	<b>99</b>			
Leather-covered multifunction steering wheel in 4-spoke design with shift paddles		<input type="checkbox"/>	<input type="checkbox"/>	<input type="checkbox"/>
Leather-covered multifunction steering wheel in 4-spoke design with shift paddles, heated		<input checked="" type="checkbox"/>	<input checked="" type="checkbox"/>	<input checked="" type="checkbox"/>
Steering wheel with electric angle and axial adjustment		<input type="checkbox"/>	<input type="checkbox"/>	<input type="checkbox"/>
Leather-covered multifunction sports steering wheel in 3-spoke design, with gearshift paddle switches, heated		<input checked="" type="checkbox"/>	<input checked="" type="checkbox"/>	<input checked="" type="checkbox"/>
Leather-covered multifunction sports steering wheel in 3-spoke design with shift paddles		<input checked="" type="checkbox"/>	<input checked="" type="checkbox"/>	<input checked="" type="checkbox"/>
Steering wheel rim with wooden segments		<input checked="" type="checkbox"/>	<input checked="" type="checkbox"/>	<input checked="" type="checkbox"/>
Selector lever in leather		<input type="checkbox"/>	<input type="checkbox"/>	<input type="checkbox"/>
Selector lever in wood		<input checked="" type="checkbox"/>	<input checked="" type="checkbox"/>	<input checked="" type="checkbox"/>
Audi exclusive selector lever in wood		<input checked="" type="checkbox"/>	<input checked="" type="checkbox"/>	<input checked="" type="checkbox"/>
Audi exclusive controls		<input checked="" type="checkbox"/>	<input checked="" type="checkbox"/>	<input checked="" type="checkbox"/>
<b>Climate control</b>	<b>100</b>			
Deluxe automatic air-conditioning		<input checked="" type="checkbox"/>	<input checked="" type="checkbox"/>	–
4-zone deluxe automatic air-conditioning		<input checked="" type="checkbox"/>	<input checked="" type="checkbox"/>	<input type="checkbox"/>
Auxiliary heating/ventilation		<input checked="" type="checkbox"/>	<input checked="" type="checkbox"/>	<input checked="" type="checkbox"/>
<b>Luggage securing and storage systems</b>	<b>101</b>			
Storage compartments		<input type="checkbox"/>	<input type="checkbox"/>	<input type="checkbox"/>
Audi exclusive coolbox		<input checked="" type="checkbox"/>	<input checked="" type="checkbox"/>	<input checked="" type="checkbox"/>
Drinks holders		<input type="checkbox"/>	<input type="checkbox"/>	<input type="checkbox"/>
Load-through facility with removable ski bag		<input checked="" type="checkbox"/>	<input checked="" type="checkbox"/>	<input checked="" type="checkbox"/>
Luggage compartment package		<input checked="" type="checkbox"/>	<input checked="" type="checkbox"/>	<input checked="" type="checkbox"/>
Audi exclusive fold away table		<input checked="" type="checkbox"/>	<input checked="" type="checkbox"/>	<input checked="" type="checkbox"/>
Audi exclusive personalisation of the fold away table		<input checked="" type="checkbox"/>	<input checked="" type="checkbox"/>	<input checked="" type="checkbox"/>

	Page	A8	A8 L	A8 L W12
<b>Further interior equipment</b>	<b>101</b>			
Door sill trims with aluminium inlays		<input type="checkbox"/>	<input type="checkbox"/>	–
Door sill trims with aluminium inlays with W12 logo, illuminated		–	–	<input type="checkbox"/>
Cigarette lighter and ashtray		<input type="checkbox"/>	<input type="checkbox"/>	<input type="checkbox"/>
Non-smoker package		<input checked="" type="checkbox"/>	<input checked="" type="checkbox"/>	<input checked="" type="checkbox"/>
230/115/100 V socket		<input checked="" type="checkbox"/>	<input checked="" type="checkbox"/>	<input checked="" type="checkbox"/>
Floor mats, front and rear		<input type="checkbox"/>	<input type="checkbox"/>	<input type="checkbox"/>
Audi exclusive carpets and floor mats		<input checked="" type="checkbox"/>	<input checked="" type="checkbox"/>	<input checked="" type="checkbox"/>
<b>MMI® and navigation system</b>	<b>102</b>			
MMI®		<input type="checkbox"/>	<input type="checkbox"/>	–
MMI® Navigation plus with MMI® touch		<input checked="" type="checkbox"/>	<input checked="" type="checkbox"/>	<input type="checkbox"/>
MMI® touch		<input checked="" type="checkbox"/>	<input checked="" type="checkbox"/>	<input type="checkbox"/>
Navigation data (hard drive)		<input checked="" type="checkbox"/>	<input checked="" type="checkbox"/>	<input type="checkbox"/>
Vehicle support based on navigation data		<input checked="" type="checkbox"/>	<input checked="" type="checkbox"/>	<input type="checkbox"/>
Driver information system with 7" colour display		<input type="checkbox"/>	<input type="checkbox"/>	<input type="checkbox"/>
<b>Radio and TV systems</b>	<b>103</b>			
Radio		<input type="checkbox"/>	<input type="checkbox"/>	<input type="checkbox"/>
Single-DVD player		<input checked="" type="checkbox"/>	<input checked="" type="checkbox"/>	–
DVD/CD Changer		<input checked="" type="checkbox"/>	<input checked="" type="checkbox"/>	<input type="checkbox"/>
Digital Audio Broadcasting reception (DAB)		<input checked="" type="checkbox"/>	<input checked="" type="checkbox"/>	<input checked="" type="checkbox"/>
TV reception		<input checked="" type="checkbox"/>	<input checked="" type="checkbox"/>	<input checked="" type="checkbox"/>
Audi sound system		<input type="checkbox"/>	<input type="checkbox"/>	–
BOSE Surround Sound		<input checked="" type="checkbox"/>	<input checked="" type="checkbox"/>	<input type="checkbox"/>
Bang & Olufsen Advanced Sound System		<input checked="" type="checkbox"/>	<input checked="" type="checkbox"/>	<input checked="" type="checkbox"/>
Audi music interface, part of the MMI® navigation plus with MMI® touch		<input checked="" type="checkbox"/>	<input checked="" type="checkbox"/>	<input type="checkbox"/>
Adapter cable set for Audi music interface		<input checked="" type="checkbox"/>	<input checked="" type="checkbox"/>	<input checked="" type="checkbox"/>
Rear Seat Entertainment		<input checked="" type="checkbox"/>	<input checked="" type="checkbox"/>	<input checked="" type="checkbox"/>

Standard equipment    Optional equipment   – not available

Country-specific variations possible. Please find out from your local Audi partner which equipment is standard and what optional equipment is available in your country.

	Page	A8	A8 L	A8 L W12
<b>Telephone and communication</b>	<b>104</b>			
Fitting for mobile phone (Bluetooth)		■	■	■
Bluetooth car phone online		■	■	□
Handset for Bluetooth car phone online, front		■	■	□
Handset for Bluetooth car phone online, front and rear		■	■	■
Bluetooth interface, part of the MMI® navigation plus with MMI® touch		■	■	□
<b>Assistance systems</b>	<b>105</b>			
Audi pre sense basic		□	□	□
adaptive cruise control with Stop&Go function incl. Audi pre sense front		■	■	■
Audi side assist including Audi pre sense rear		■	■	■
Audi lane assist		■	■	■
Night vision assistant with highlighting of detected pedestrians		■	■	■
Parking system plus		■	■	—
Parking system plus with reversing camera		■	■	□
Speed limit display		■	■	■
Cruise control		□	□	□
Hold assist		□	□	□
<b>Suspension/brakes</b>	<b>106</b>			
Audi drive select		□	□	□
Dynamic steering		■	■	■
adaptive air suspension		□	□	□
adaptive air suspension sport		■	■	■
Braking system		□	□	□
Electromechanical parking brake		□	□	□

	Page	A8	A8 L	A8 L W12
<b>Technology/safety</b>	<b>107</b>			
Body, Audi Space Frame (ASF)-construction		□	□	□
Side impact protection		□	□	□
Airbags		□	□	□
Deactivation switch for front-passenger airbag		■	■	■
Integrated head restraint system		□	□	□
Seat belts		□	□	□
Audi exclusive seat belts		■	■	■
Warning and indicator lamps		□	□	□
First-aid kit		□	□	□
Warning triangle		□	□	□
Anti-lock braking system (ABS)		□	□	□
Traction control (ASR)		□	□	□
Electronic differential lock (EDL)		□	□	□
Electronic Stabilization Programme (ESP)		□	□	□
servotronic		□	□	□
tiptronic		□	□	□
quattro®		□	□	□
quattro® with sports differential		□ <sup>1</sup>	□ <sup>1</sup>	■
Misfuelling protection		□	□	—
Recuperation		□	□	□
Start/stop system		□ <sup>-2</sup>	□ <sup>-2</sup>	—
<b>Audi extended warranty</b>	<b>107</b>			
Audi extended warranty		■	■	■

Equipment for the Audi A8 illustrated (p. 8–25):

Paint finish: Ice Silver, metallic

Wheels: Forged aluminium wheels, 10-parallel-spoke design

Seat covers: Valcona leather, titanium grey

Inlays: upper inlay in Vavona wood assam grey; lower inlay in brushed aluminium silver

Equipment for the Audi A8 illustrated (p. 10–22):

Paint finish: Quartz Grey, metallic

Wheels: Cast aluminium wheels in 5-arm design

Seat covers: Valcona leather, silk beige

Inlays: upper inlay in walnut tree root wood brown; lower inlay in high gloss black; extended aluminium look on the interior

Equipment for the Audi A8 L illustrated (p. 26–33):

Paint finish: Phantom Black, pearl effect

Wheels: Forged aluminium wheels, 10-parallel-spoke design

Seat covers: Valcona leather, Audi design selection brass beige

Inlays: upper inlay in Fine grain birch wood pearl beige; lower inlay in brushed aluminium silver; extended aluminium look on the interior

Equipment for the Audi A8 L W12 illustrated (p. 34–41):

Paint finish: Phantom Black, pearl effect

Wheels: Cast aluminium wheels in 15-spoke design

Seat covers: Valcona leather, silk beige

Inlays: upper inlay in Fine grain ash velvet brown; lower inlay in brushed aluminium silver; extended aluminium look on the interior

□ Standard equipment   ■ Optional equipment   □■ Standard-/optional equipment varies by model   — not available   □— optional equipment/not available (depending on model)

Country-specific variations possible. Please find out from your local Audi partner which equipment is standard and what optional equipment is available in your country.

<sup>1</sup> Standard for 4.2. TDI quattro.   <sup>2</sup> Standard for 3.0 TDI quattro.

Equipment Audi A8/A8 L/A8 L W12			
230/115/100 V socket	101	Body, Audi Space Frame (ASF)-construction	107
4-zone deluxe automatic air-conditioning	100	BOSE Surround Sound	103
Adapter cable set for Audi music interface	104	Braking system	106
adaptive air suspension	106	Centre armrest, front	98
adaptive air suspension sport	106	Centre armrest, rear	98
adaptive brake light	93	Cigarette lighter and ashtray	101
adaptive cruise control with Stop&Go function		Comfort centre armrest, front	98
incl. Audi pre sense front	105	Comfort head restraints, rear	98
adaptive light	92	Comfort seats, front with optional seat ventilation	84
adaptive light including		Comfort seats, front	82
variable beam angle adjustment	92	Comfort sports seats, front	
Additional reading lights in the rear	93	with/without seat ventilation	81
Airbags	107	Convenience key	95
Alcantara/Leather combination	86	Cruise control	106
Aluminium look on in the interior	89	Dark-tinted windows (privacy glazing)	95
Ambient lighting	93	Deactivation switch	
Anti-lock braking system (ABS)	107	for front-passenger airbag	107
Anti-theft alarm	95	Digital Audio Broadcasting reception (DAB)	103
Audi design selection balao brown	74, 75, 87	Door sill trims with aluminium inlays	101
Audi design selection brass beige	76, 77, 87	Double/acoustic glazing	95
Audi drive select	106	Drinks holders	101
Audi exclusive	68-73	Driver information system with 7" colour display	102
Audi exclusive carpets and floor mats	101	DVD/CD Changer	103
Audi exclusive controls	99	Dynamic steering	106
Audi exclusive coolbox	101	Electromechanical parking brake	106
Audi exclusive fold away table	101	Electronic differential lock (EDL)	107
Audi exclusive inlays	88	Electronic Stabilization Programme (ESP)	107
Audi exclusive leather upholstery and trim	83, 85-87	Engine start-stop button	95
Audi exclusive parcel shelf in Alcantara	87	Exhaust tailpipes	96
Audi exclusive personalisation of the fold away table	101	Extended aluminium look on the interior	89
Audi exclusive rear foot rests	98	Exterior mirrors	93
Audi exclusive seat belts	107	First-aid kit	107
Audi extended warranty	107	Fitting for mobile phone (Bluetooth)	104
Audi Genuine Accessories	109-111	Fitting for Tracking Assistant	95
Audi lane assist	105	Floor mats, front and rear	101
Audi music interface	104	Foot rests at the rear	98
Audi pre sense basic	105	Garage door opener (Homelink)	95
Audi Service®	108	Glass tilt/slide sunroof	94
Audi side assist including Audi pre sense rear	105	Grab handles with wooden segments and front and rear	98
Audi sound system	103	Handset for Bluetooth car phone online	
Auxiliary heating/ventilation	100	Headlining/Audi exclusive	
Bang & Olufsen Advanced Sound System	103	Alcantara headlining	87
Bluetooth car phone online	104	Heat-insulating glass	95
Bluetooth interface, part of the MMI® navigation plus with MMI® touch	105	Hold assist	106



**AUDI AG**  
85045 Ingolstadt  
[www.audi.com](http://www.audi.com)  
Valid from April 2011

Printed in Germany  
133/1130.82.18

The models and equipment versions illustrated and described in this brochure and some of the services listed are not available in all countries. Some of the cars illustrated are equipped with optional equipments for which an extra charge is made. Details concerning the delivery specifications, appearance, performance, dimensions and weights, fuel consumption and running costs of the vehicle were correct to the best of our knowledge at the time of going to press. Deviations from the colours and shapes shown in the illustrations may occur. No liability is accepted for errors and printing errors. The right to introduce modifications is reserved. Not to be reproduced, including in part, without the written approval of AUDI AG.

This brochure is printed on paper made from pulp bleached without the use of chlorine.