

1981

The Audi Coupé



The 1981 Audi Coupé

Inside every Audi Coupé you'll find the impossible. Accommodation for 5 full size adults. 15.6 cubic feet for luggage. 5 cylinder, 115 bhp engine. 5 speed gearbox. 0-60 in 10.3 seconds. Top speed 115 mph. Electric windows. Power steering. Central locking doors.

It all adds up to the end of the cliché coupé.

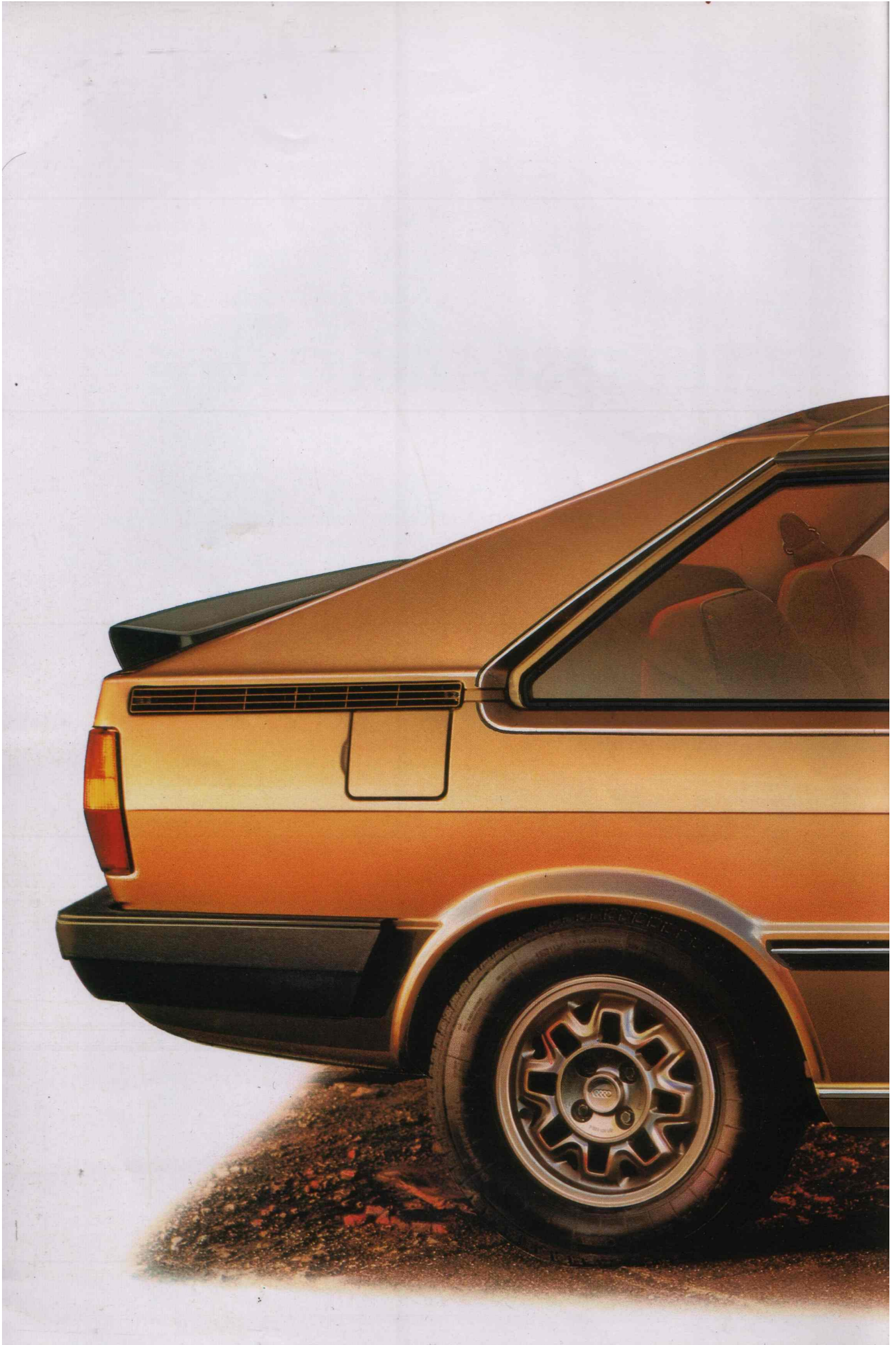

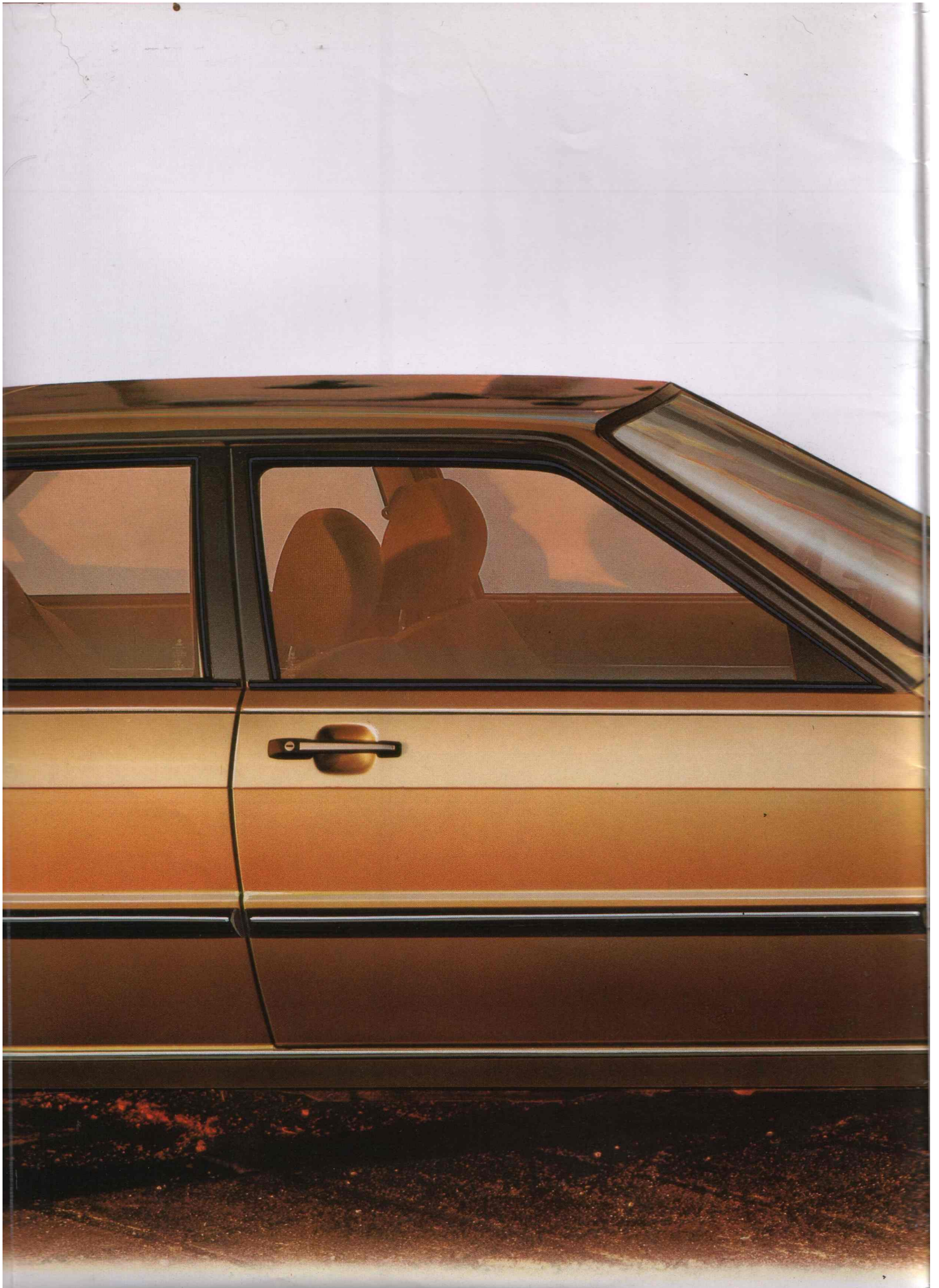

This brochure is intended to show the general appearance of the Audi Coupé. Please note that for the 1981 model year a nearside rear view mirror is fitted. The illustrations in the brochure do not show this feature.

During the origination of this brochure, the manufacturer's illustrations depicted left hand drive vehicles. However, to facilitate the brochure's application within the United Kingdom, the illustrations have undergone a process that makes possible the presentation of right hand drive vehicles. The process involves the "reversing" of negatives and as a result some minor items of specification have become slightly mispositioned.

Due to a continuous process of modification by the manufacturer, some change in specification may occur after the publication of this brochure. Kindly confirm specification with your authorised Audi dealer at the time of placing your order.

The pages dealing with the summary of specification give exact details of equipment at the time of publication.

The details given in this brochure relate to models of the 1981 model year.



More jazz, less juice.

The Audi Coupé is the only five cylinder coupé in the world.

Why five cylinders? To begin with, a five cylinder engine com-

bines incredible smoothness with the kind of economy we need today.

The engine's design gives it

excellent power at low speed. And at higher speeds, noise remains amazingly low.

But that's only half the story.

Our five cylinder engine also offers a better weight-to-performance ratio than six cylinder engines. And weight, along with



shape, is a major factor in saving fuel.

For optimum utilisation of fuel, the Audi Coupé also has electronically controlled ignition and a five speed gearbox as standard equipment.

This fifth gear is not so much for the sake of sport motoring as for the sake of economy. The other big advantage of the high

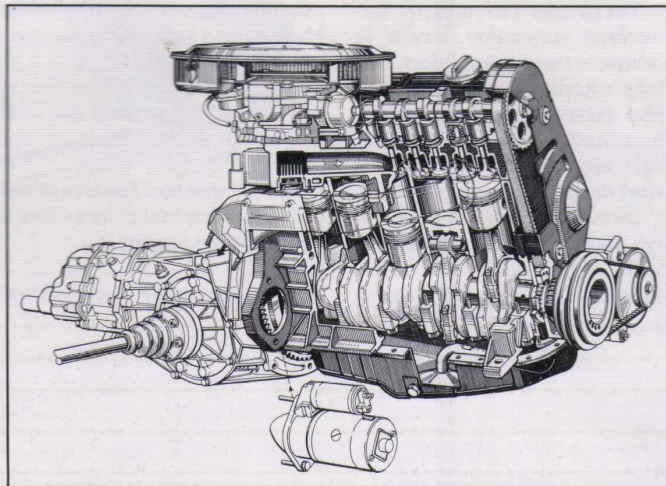

The powerful five-cylinder carburettor engine with an output of 85 kW (115 DIN bhp).

ratio fifth gear is that high speed motoring is carried out with less engine revolutions, and that means quieter cruising and increasing mechanical durability.

And for further convenience, there's automatic transmission – an optional extra.

The details. The powerful five cylinder engine has an output of 115 bhp DIN with a capacity of 1.9 litres. The acceleration figures give you an idea of its performance: 0–50 mph in 6.9 seconds, 0–60 mph in 10.3 seconds. A high torque of 154 Nm is obtained at a rev.speed of 3700 rpm. You never know when you'll need that kind of pulling power.

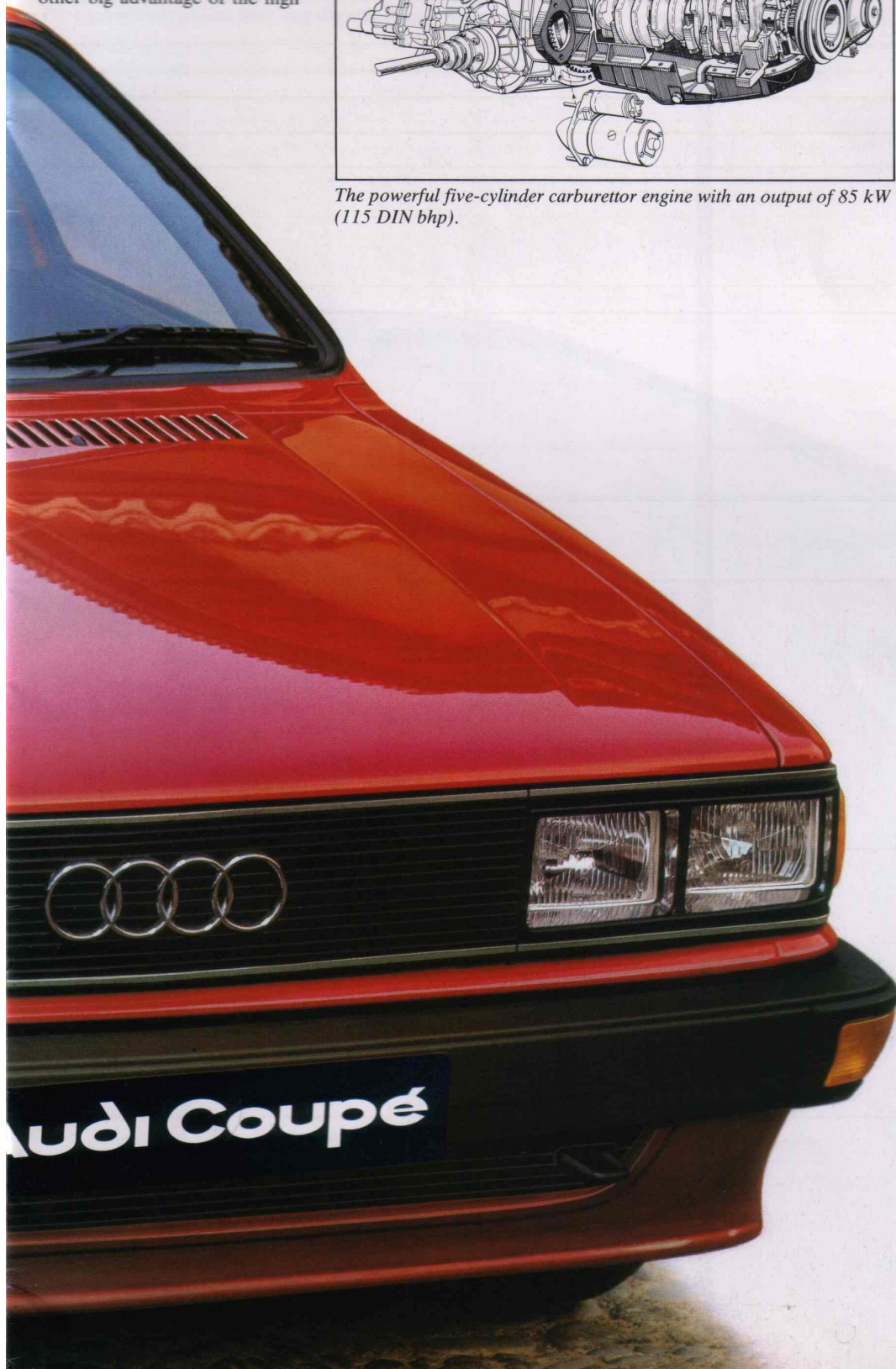

Racy but spacey.

The combination of a stylish exterior, roomy interior and advanced engineering makes the Audi Coupé virtually unique.

Features include front wheel drive, long wheelbase, wide track, carefully designed springing and shock absorption, self-stabilising negative roll radius steering and a dual diagonal circuit brake system.

Front wheel drive. The drive wheels are the ones that are steered, and the Coupé, like other Audis, offers outstanding directional stability. You'll appreciate this particularly on wet and slippery roads. At the same time, front wheel drive makes the Coupé almost oblivious to side wind.

The chassis. The carefully harmonised suspension results in complete motoring comfort. The long wheelbase and wide track also make major contributions here. And the Coupé comes with light alloy wheel rims and wide steel radial ply tyres as standard.

Directional stability. Like every Audi, the Coupé has self-stabilising negative roll radius steering. This helps the car from

veering from its course when braked on a loose or slippery surface.

The dual circuit brake system has disc brakes in front and self-adjusting drum brakes at the rear.

Other standard features in the Coupé are a brake servo and a brake pressure regulator.



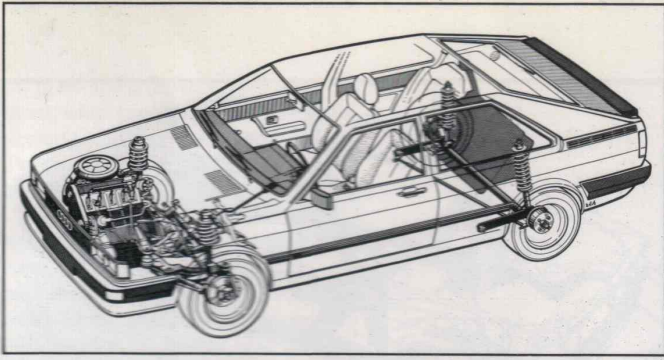

The sophisticated chassis with long wheel base and wide track.



Safety first.

The Audi Coupé has safety built into it, an integral part of its Audi pedigree. In fact, you'll find the same pre-occupation with safety in the new Coupé that you've come to expect from each and every Audi before it, the Audi 80, 100 and 200.

The Coupé incorporates many advanced safety features. Like self-stabilising negative roll radius steering.

We have paid special attention to passenger safety in various types of accidents.

Results of our comprehensive programme of crash tests have led us to design the rigid-cell passenger compartment with crumple zones in front and at the rear. These zones will absorb much of the impact if a collision should occur. Safety locks help stop the doors bursting open in the event of an accident.

As in all Audi models, the instrument panel is made of resilient material and has rounded contours to make an important contribution to minimising the risk of injury.

Interior impact on the steering column is minimised by a sheer-

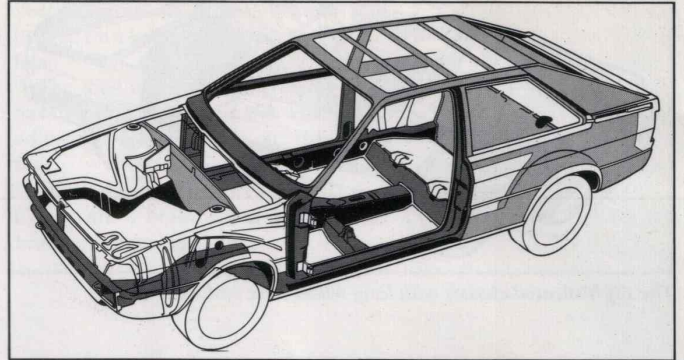

The rigid passenger cell compartment with crumple zones in front and at rear.



off plate and a flexible mesh element, while outside impact is deflected by a detachable coupling. This helps reduce the possibility of injury.

For further safety, the seats are firmly anchored. The front seats have adjustable head restraints and three-point seat belts with locks which guarantee optimum belt position no matter how the seats are adjusted.

There are also three seat belts for the rear seat passengers.

Bronze-tinted glass is fitted all round, and the laminated windscreen has a green-tinted strip at the upper edge to provide additional protection against glare.

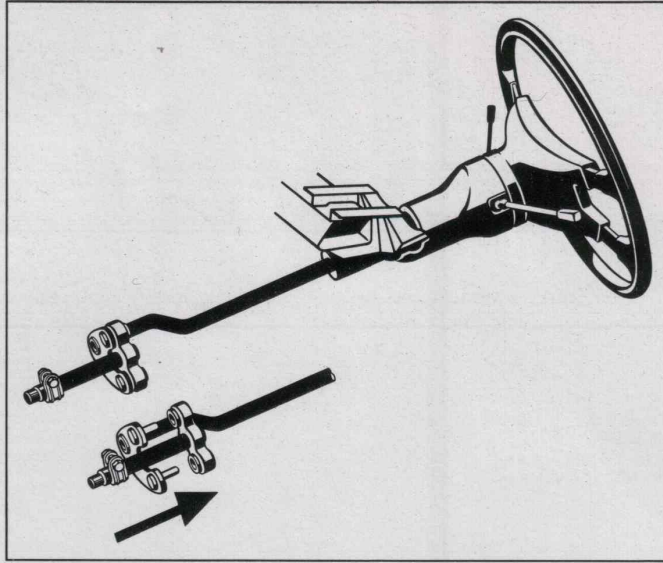

The Audi Coupé's safety steering column with flexible mesh element.







A major advance on the 2+2. The 2+3.

At last you can drive a coupé without sacrificing your creature comforts.

For within its streamlined aerodynamic shape, the Audi Coupé offers a surprising amount of interior space, with the kind of dimensions some saloons would envy.

Believe it or not, there is room for 3 full-size adults in the back.

Nor do we stint those in the front. The sophisticated design of the bucket seats provides excel-

lent lateral support and ample room to stretch out. The driver's seat is also adjustable for height. Which means that everyone can find his or her own optimum driving position.

And there's more to boot. In addition to the interior room, the Audi Coupé has plenty of space for luggage, with a capacity of 15.6 cu.ft. The boot is also fully lined and illuminated, so you can find your way around in the dark.

Even the Coupé's fuel tank is

bigger than most, holding nearly 15 gallons, so you can drive for almost 500 miles on a single tankful.

More surprises. As an aid to thrifty motoring, there is an indicator that lights up whenever a change to a higher gear would bring the engine to a more efficient, and economical, speed range. There is also an economy gauge to encourage self-restraint when using the accelerator.

These two features are part of

the well designed instrument panel, which provides all important information at a glance. Including speed, time of day, engine speed, fuel reserves, oil pressure, oil temperature and voltage.

The switches for the lights, heated rear window, indicators and all the rest are within easy reach. The two-speed windscreen wipers come with intermittent operation and wash/wipe settings. And there's a rear wiper



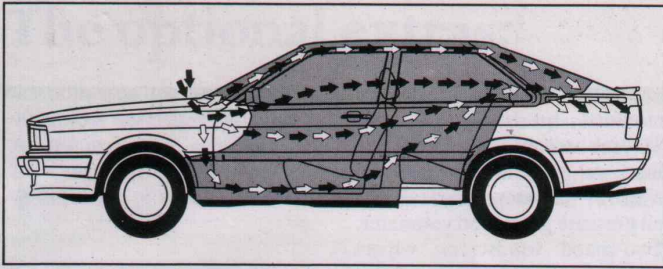

The quick-acting, adjustable heating and ventilation system for a cool head and warm feet.

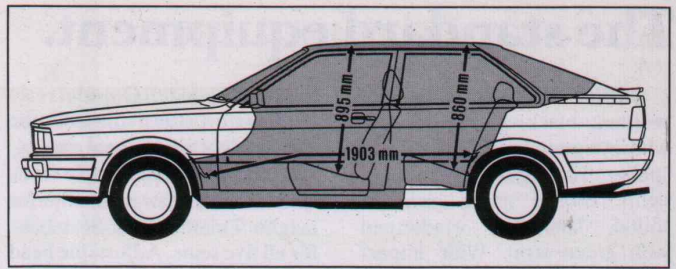

with wash/wipe settings as well. For your greater comfort, as well as safety, we've added a few more touches. The Coupé has no fewer than 30 sources of light, so

you can see — and be seen — at night. The sophisticated heating and ventilation system provides fresh air and the required temperature

to ensure total comfort whatever the season. And finally, the interior colours are carefully matched and non-distracting, to help put you

at ease, and keep you that way, however long your ride. All in all, the Audi Coupé is an ideal long-distance car.

Radio installation at extra charge.



The standard equipment.

Outside: Bumpers bars with resistant black, plastic coating, with integrated indicators, front spoiler, rectangular twin headlights, bronze tinted glass all round, laminated windscreen with green strip. Wide impact

strip at the side. Outside rear-view mirror, adjustable from the inside. Light alloy wheel rims.

Inside: Front sports style seats, with driver's seat adjustable for height. Tweed fabric. Seat belts for all five seats. Adjustable head

restraints in front and two moulded head-rests at rear. Several storage compartments. Easy to read instrumentation with rev.-counter, quartz clock, oil pressure gauge and voltmeter. Two-speed windscreen wipers

with intermittent operation and automatic wash/wipe settings.



Clearly arranged instrument dials.



Halogen headlights.



Light alloy wheel rims.

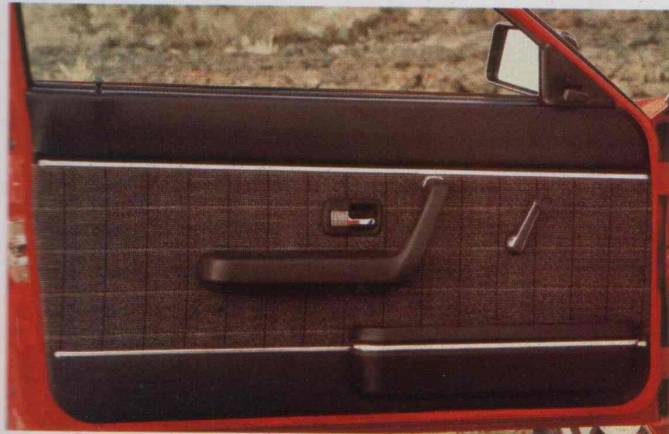

Fabric lining on doors.

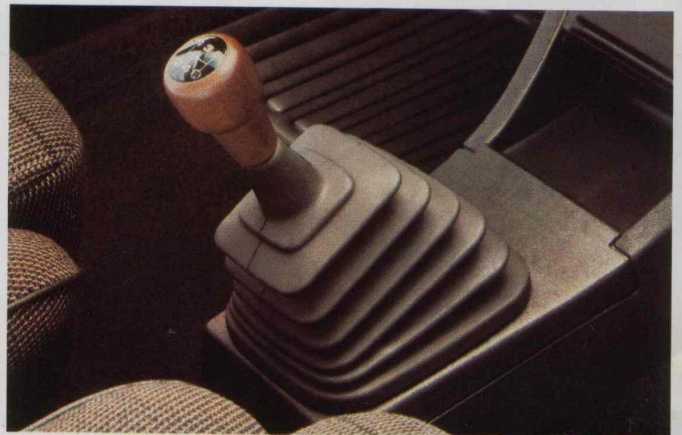

Five-speed gearbox.

The optional extras.

We have only a few options to offer you on the Audi Coupé. All the major luxury equipment is incorporated in the original specification of the car.

Central locking for the doors and luggage compartment, a wash-wipe system for the rear window, electric windows and power steering are all standard fitments.

A sunroof, integrated front fog lamps, a head lamp washing system and automatic transmission are offered as optional equipment as well as a wide range of radio/stereo installations.

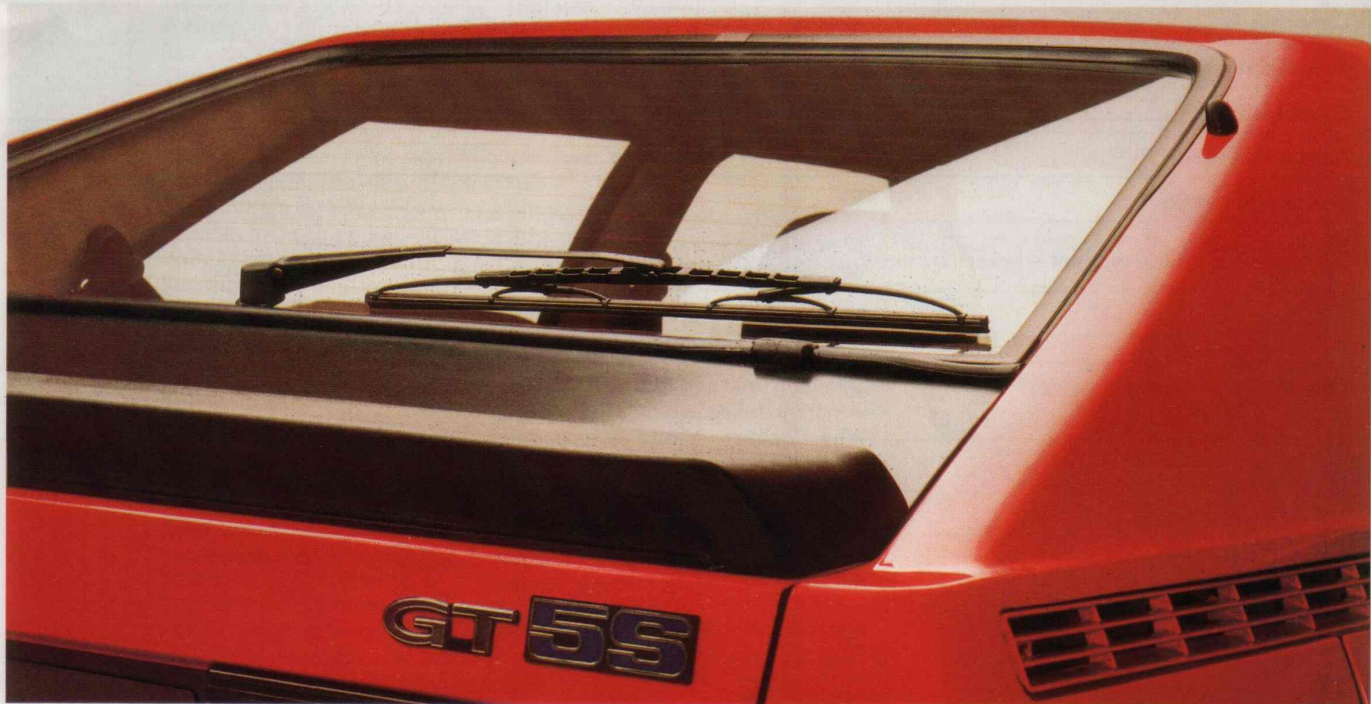

Rear window wiper with washing system (standard).

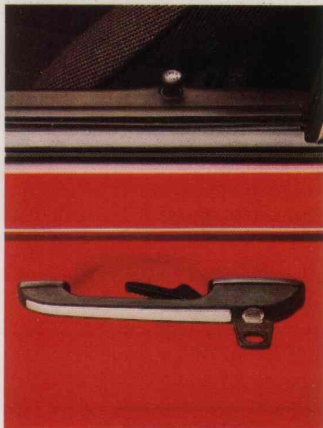

Central locking facility (standard).

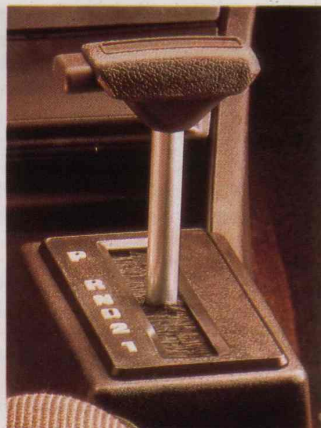

Automatic transmission.

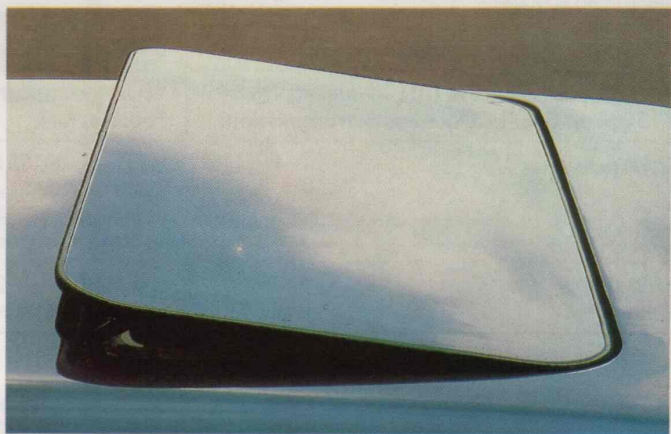

Steel sunshine roof.

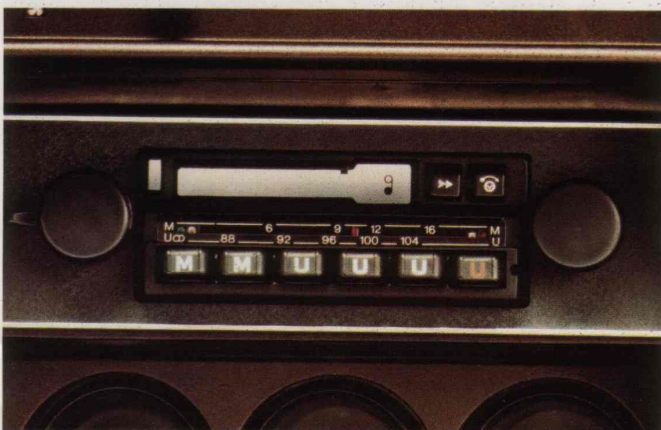

Stereo cassette / radio installation.



Headlight washing system.

Technical Data.

	Audi Coupé GT 5 S 85 kW (115 DIN bhp)
Engine:	Five cylinder, in-line engine
Induction:	Down-draught carburettor
Capacity:	1.9 litres (1921 cc)
Bore and stroke:	79.5 x 77.4 mm
Output:	85 kW (115 DIN bhp) at 5900 rpm
Maximum torque:	154 Nm at 3700 rpm
Compression ratio:	10
Electrical system:	12-volt/63 Ah battery, alternator with switchgear 55 A max. With automatic transmission 65 A max., transistorized ignition system.
Gearbox:	Fully-synchronized, five-speed gearbox, with over-drive top gear. Automatic transmission.
Chassis:	Springing front and rear with coil springs and telescopic shock absorbers – in front as suspension struts. Stabilizer front and rear. Wheel location: in front via suspension struts and lower wishbones, with track-stabilizing steering roll radius, and torsion beam axle at rear. Brake system: dual diagonal brake system with disc brakes in front and drum brakes at rear, brake servo and brake pressure regulator.
Steering:	Rack and pinion steering. Power assisted. Safety steering column with detachable coupling, steering damper.
Wheels/tyres:	Light alloy wheel rims 6 J x 14 Steel radial ply tyres 185/60 HR 14
Top speed with 5-speed/automatic gearbox:	113/109 mph (183/177 km/h)
Acceleration with half payload, 5-speed gearbox/automatic transmission:	0–50 mph (80 km/h) 6.9/ 8.5 seconds 0–60 mph (100 km/h) 10.3/12.5 seconds
Fuel consumption to DIN 5-speed-gear box/automatic transmission:	Fuel consumption figures available from your local V.A.G dealer. Four star fuel.
Dimensions:	Wheel base 100 ins. (2542 mm), track, front/rear 55.1/55.9 ins. (1400/1420 mm), maximum outside length/width/height 171.2/66.2/53.1 ins. (4349/1682/1350 mm), minimum ground clearance 4.7 ins. (120 mm), turning circle diameter approx. 34.1 ft (10.4 m).
Weights:	Unladen weight 2249 lbs (1020 kg), permissible total weight 3263 lbs (1480 kg), permissible axle load front/rear 1896/1653 lbs (860/750 kg).
Trailed loads braked/unbraked:	2646/1191 lbs (1200/540 kg), with automatic transmission 2866/1191 lbs (1300/540 kg). Please note: With increasing altitude engine performance is unavoidably reduced. From 1000 metres above sea level on and for every 1000 metres thereafter, 10 % of the total weight (permissible trailed load + permissible total weight of the towing vehicle) is to be deducted.
Luggage compartment capacity:	15.6 cu.ft.

Equipment:

Exterior equipment

Bronze-tinted windows all round, laminated windscreen with green strip at the upper edge
Plastic-covered bumpers to the wheel extended arches
Front spoiler
Rear spoiler on luggage compartment cover
Central locking facility for doors and luggage compartment
Rectangular twin halogen headlights
Back-up lights
Outside rear-view mirror on the driver's side adjustable from inside
Outside rear view mirror on the passenger's side, adjustable from inside
Light alloy wheel rims
Wide impact strip, at the side at bumper level, with polished ornamental strip
Polished ornamental strip on door sills
Black outside door handles with polished insert
Narrow, two-colour double/strip at the sides
Wide lateral colour strips below the bumper impact strip, with the same colour continuing in the front spoiler
Red fluorescent strip between the rear lights
Lockable tank cap

Interior equipment

Tweed check fabric seat upholstery
Bucket seats in front, bench at rear with moulded seats
Height-adjustable driver's seat
Head restraints, adjustable, in front
Moulded headrests at rear
Electric window winders
Radio preparation
Seat belts for all five seats
Rear ashtray
Velour carpeting lining in the footwell
Sun visors, recessed in the headlining
Rear window wiper with washing facility
Day/night rear view mirror
Headlining in matching colour
Fabric lining on doors and sides as on seats, with storage compartments
Four-spoke sports steering wheel
Centre console with oil temperature and pressure gauges and voltmeter
Instrument panel, including rev. counter, clock, consumption indicator, and gearshift indicator
Dual circuit and hand brake indicator lamp
Trip mileage recorder
Anti-dazzle instrument panel
Combined heating and ventilation system with three-speed hot and fresh air blower
Windscreen wiper/washing system with two wiper speeds with intermittent and automatic wash/wipe setting

Miscellaneous features of equipment

Fully lined luggage compartment
Separate luggage compartment light
Permanent sealing for the underfloor
Sealed body cavities

Optional features at extra charge

Headlight washing system
Halogen fog headlights
Sunroof. Check with dealer for availability
Automatic transmission

Upholstery for the Audi Coupé:

Standard tweed check seat upholstery.

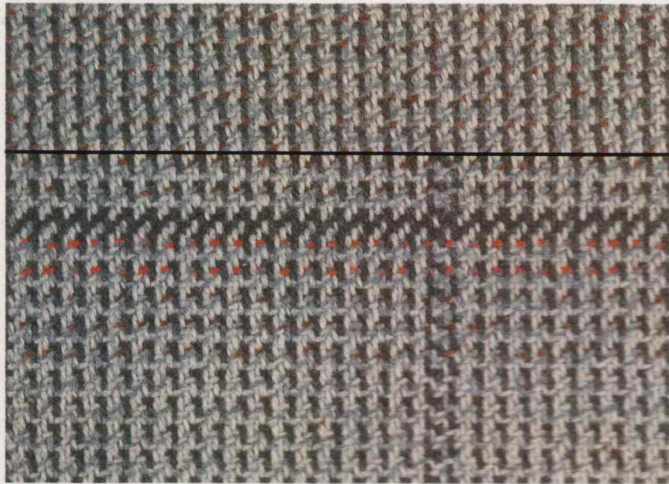

Azure

KA

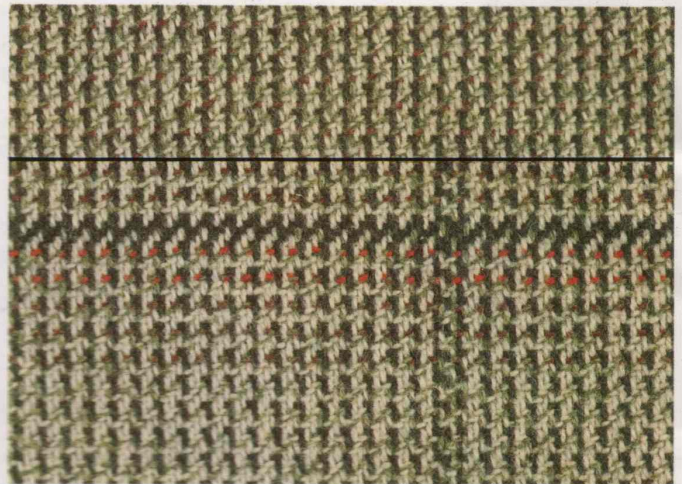

Sedge

KB

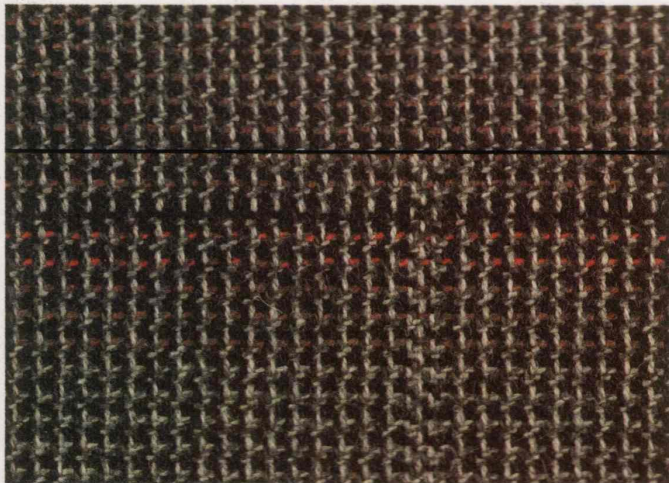

Negro

KC

Combinations		Azure	Sedge	Negro
Interior trim				
Exterior finishes:				
Mars red/medium red Diamond silver metallic/medium red	G6			
Metallic finishes:				
Helios blue metallic/azur metallic Light red metallic/azure metallic	W5			
Indiana red metallic/red metallic Diamond silver metallic/red metallic	W9			
Saturn metallic/maroon metallic Light red metallic/maroon metallic	Y3			
Inari silver metallic/sedge metallic Light red metallic/sedge metallic	Y4			
Meteor metallic/dark grey metallic Light red metallic/dark grey metallic	Y5			
Onyx metallic/sedge metallic Light grey metallic/sedge metallic	Z2			
Diamond silver metallic/grey metallic Light red metallic/grey metallic	Z4			

Paintwork:

Special colour/second colour



Mars red/medium red

G6

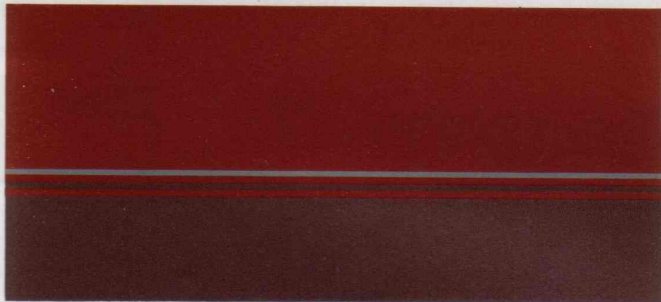

Indiana red metallic/red metallic

W9

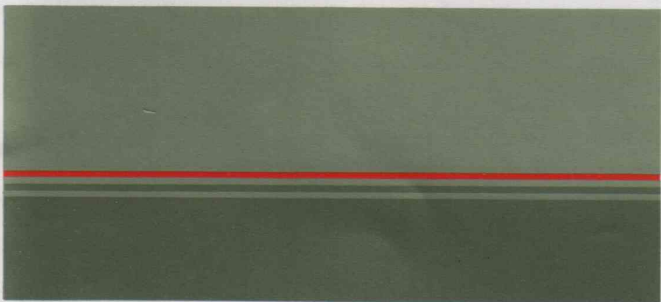

Inari silver metallic/sedge metallic

Y4

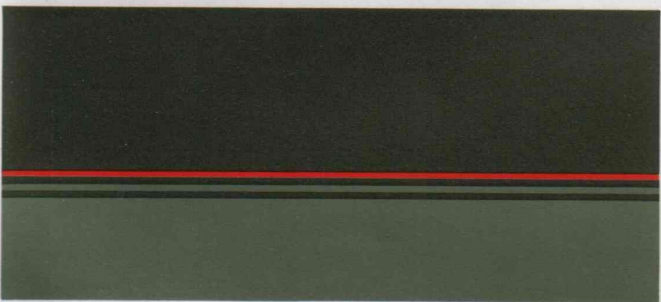

Onyx metallic/sedge metallic

Z2

Metallic colours/second colours

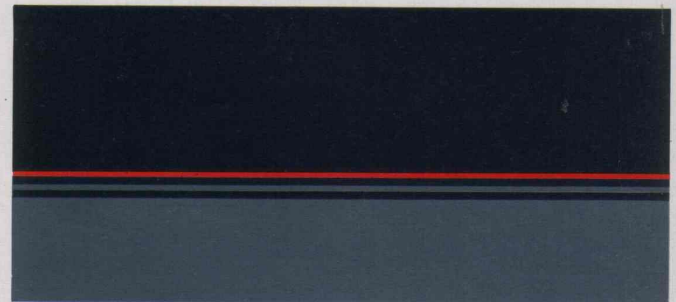

Helios blue metallic/azure metallic

W5

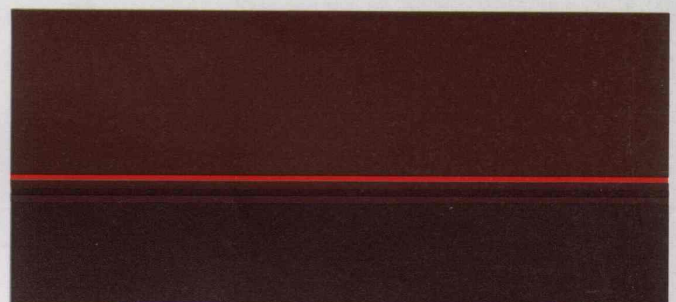

Saturn metallic/maroon metallic

Y3



Meteor metallic/dark grey metallic

Y5



Diamond silver metallic/grey metallic

Z4

Printing processes cannot give an exact reproduction of original colours shades. This applies to both paintwork and upholstery fabric colours. Your V.A.G dealer has samples of the paint and fabrics.

In addition to the many advantages of the Audi Coupé there are the advantages offered by a major manufacturer: a comprehensive warranty and an extensive dealer network offering a wide range of services.

The advanced 1 year warranty. Unlimited mileage. A manufacturer who gives this kind of warranty must be absolutely convinced of the quality of his cars. However, with this warranty we believe we give you more than just proof of quality. We give you the assurance that you made the right choice. For economical, comfortable and safe motoring. The 1 year warranty has worldwide validity.

6 year warranty. Audi body work carries a 6 year warranty against major corrosion and rust. New vehicles subject to this warranty must be cared for in accordance with the operating instructions. Bodywork must be inspected at prescribed intervals by an authorised Audi dealer. Full details of this warranty system are available from your Audi dealer.

A wide service network. There is a wide network of Audi service stations around the world. The Audi service includes the latest in high efficiency equipment and special tools to provide maintenance

and service for your car throughout its long life.

All this guarantees a long life and high resale value for your Audi.

Trained personnel. The personnel of the Audi companies, service managers, engineers, reception engineers, etc., receive regular training in factory-approved schools. At the factory there is a special department which carries out research into new servicing techniques in co-operation with Audi dealers. All this results in quicker, better quality service and lower maintenance costs.

Spare parts and exchange units. The Audi service includes a well-organized Parts Service. Guaranteed, high-standard exchange units are available from all Audi dealers. Genuine exchange units undergo stringent inspection at the factory.

Financing, insurance, leasing. The Audi service may include financing, insurance and leasing for your car. Your Audi dealer will be pleased to give you information on the availability of these services.

Personal Export. The Audi service also includes the Personal

Export facility which arranges for Overseas, Military and Diplomatic sales of Audi vehicles.

For information on this service the Personal Export Centre, 95 Baker St. London, W1, should be contacted. (Tel. 01 486 8411)

Success through engineering

