



A8

Audi A8



There's a new class of flagship.

As the finest sedan to wear the four rings, the Audi A8 represents a step up in class. At the pinnacle of prestige, it embodies the notion of progress. Perhaps it's best to think of the A8 as luxury unshackled from traditional expectations. Which is why, along with Audi engineering and design expertise, the A8 offers new technological possibilities, to better connect the driver to the drive. There are notable Audi touches, like Audi quattro® all-wheel drive, brilliantly iconic LED lighting technology and a quality of finish unequalled in the industry. But it goes further. All told, it represents what's possible when a company steps past tradition to create something of stature that appeals to those with a sense of adventure.

.01 - Full LED Headlight Technology

Intense, brilliant and unmistakable, the optional full LED headlights mimic daylight, making objects ahead of you easier to spot, while helping reduce strain on the driver's eye.



W12

A tradition, refined.

The twelve cylinders that deliver refined power make the Audi A8 L W12 the elite among the elite. Building on the achievements of previous generations, the W12 represents the pinnacle of engineering. It's not just about power—although the 6.3-liter W12 engine with Audi FSI® direct injection produces 500 hp and 463 lb-ft of torque—it's how that power is felt by the driver. As delivered through Audi quattro®, rear-biased torque distribution helps ensure that the ride is smooth, the handling is true, and the acceleration is always memorable. With an aluminum-silicon alloy reducing the engine weight, and large displacement delivering effortless thrust and improved efficiency,¹ the W12 has built on the Audi heritage of engineering and further refined it, setting the W12 apart from just about anything on the road.



.02 - Design Lines

The design of the A8 delivers status with dynamism, sportiness with elegance. From its Dynamic line that brings the vehicle closer to the road to the signature flow of its Character line, the A8 is an uncompromised expression of singular stature and luxurious style.

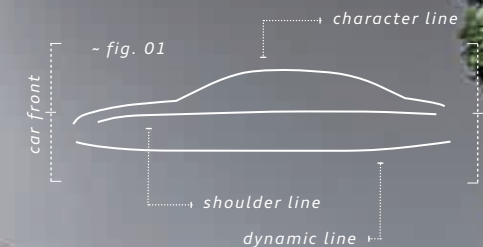



At home with the checkered flag and the red carpet.

Whether at the finish line or the receiving line, the Audi S8 is a winning choice. This is an uncompromising sports-tuned flagship that can only be described as progressive luxury performance, something that makes the S8 as much Hollywood as it is Grand Prix. It not only sets off flashbulbs with its powerfully realized style, it also pops pulses with a 4.0-liter biturbo V8 producing an astonishing 520 hp and 481 lb-ft of torque—numbers that put real meaning in your throttle. When you are the driver of an S8 you become part of an exclusive club, a group of drivers who understand that performance and power are not optional, but an extension of who you are.

S8

ENGINE // 4.0-liter biturbo TFSI® V8 engine developing 520 hp and 481 lb-ft of torque

DRIVETRAIN // Audi quattro® all-wheel drive with sports differential, eight-speed Tiptronic® automatic transmission

CHASSIS // S8 tuned Audi adaptive air suspension, Audi drive select and dynamic steering

BRAKES // 15.7" ventilated front disc brakes with six-piston calipers and S8 logo, 14.0" ventilated rear disc brakes

PERFORMANCE // Top track speed of 155¹; acceleration from 0 to 60 mph in 3.9 seconds

¹ Top track speed is electronically limited in the U.S. Obey all speed and traffic laws.



There's more information on the Audi Sport model line in the all-new 2013 Audi Sport brochure. See your dealer or go to audiusa.com for details.

It's easy to provoke a response. The trick is to evoke an emotion.

Designed to satisfy the driver who demands that every detail be thoroughly examined, the Audi A8 is built to be the new benchmark for progressive design. Matching luxury with sportiness, commanding presence with sophistication, the A8 announces its arrival with Audi signatures like the iconic shape of the Audi Singleframe® grille and illumination of adaptive xenon plus headlights. It says farewell with a sculpted coupe-like rear and stunning LED taillights, to give onlookers something to remember as it passes. It may be that the emotion we evoke is envy.



2013 Audi A8 shown in Ice Silver metallic with Sport design, Sport plus, and Driver Assistance packages.

A8

.03 - Sport Plus Package

For those looking to take the gloves off. The available Sport plus package infuses athleticism by providing enhancements such as sport-tuned Audi adaptive air suspension, 20" five-segment-spoke design alloy wheels with summer performance tires,¹ and a sports differential, allowing you to test the limits of this specimen—if there are any.

.04 - Power Trunk

For added convenience, an available power trunk with open/close feature ensures that the trunk lid opens and closes effortlessly, while the hands-free release function operates by simply moving your foot under the rear of the A8.

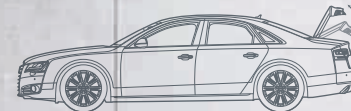

- fig. 02



.05 - Power Soft-closing Doors

Simply pull the door toward you and let it fall lightly into the latch. The Audi A8 does the rest, as available power soft-closing doors utilize an electric actuator that closes the door flush automatically.

2013 Audi A8 4.0T shown in Phantom Black pearl with optional 20" 10-parallel-spoke design alloy wheels.

¹ See Wheels page of this brochure for important safety information regarding summer performance tires.



.06 - Valcona Leather

Soft and obsessively processed for comfort, this special grain of available leather, unique to Audi interiors, gives the Audi A8 a sumptuously modern, irresistible texture that demands to be felt.



Rewriting the elements of style.

Spacious design and meticulous craftsmanship are hallmarks of the Audi A8 interior. You feel the space as the curve of the door continues its sweep across the instrument panel, helping to frame your driving environment in visual style. You feel the craftsmanship in the highest standards of materials and finishes. Once seated, you'll notice that first-class comfort envelops you—from the available 22-way power comfort front seats to the unique design of the gearshift lever, which helps your hand rest while you control the Audi MMI® system. It's the comprehensive attention to your needs—and the anticipation of them—that changes the definition of style from form to something deeper.

.07 - Ambient Lighting

At the end of a day, the beginning of a night, or anytime in between, customizable lighting in your Audi A8 can capture your mood, change it or illuminate the way you really feel. Audi designers meticulously crafted LED ambient lighting to provide a comforting glow to the interior of your A8. You can use it to create a singular sanctuary to help you exhale after another long day. With three color choices and four zones, you can brighten or dim the interior to create the optimal effect, whether you are looking for relaxation or invigoration. You are, as always, in control of your environment—we'll just help with your mood.



2013 A8 L shown in Nougat Brown leather with Comfort package and optional full LED headlights.

A painstaking dedication to your comfort.

The quality of workmanship in the Audi A8 is evident from the craftsmanship in our technologies: difficult to implement but easy to enjoy. With standard, 18-way adjustable seats and available 22-way comfort front seats, we show our compulsive dedication to your comfort. This, for Audi engineers, is truly a labor of love. We spend as long as it takes to provide you with a more comfortable and enjoyable ride. To us, that's time well spent.

22



.09 - 22-way Comfort Seats

Adding to the plush interior of the Audi A8 are the available 22-way driver and front passenger comfort seats that offer lumbar support, ventilation and massage functions.

.08 - Sport Diamond-stitched Leather

One of our most popular interior options is now available on all A8 3.0T and 4.0T models: Sport diamond-stitched leather. This premium, supple leather captures the essence of Audi—using the kind of materials and finish that show our commitment to luxury craftsmanship along with our passion for performance.



.10 - Ventilated Front Seats with Massage Function

Available front seat ventilation offers multiple speeds of cooling, while its customizable massage function helps soothe or invigorate the body during extended drives.

Luxury, whatever your perspective.

No matter where you sit, the Audi A8 L with a choice of available rear seat packages embodies the living image of luxury. Side to side, front to rear, the expansive interior of the A8 L includes the kind of thoughtful details, matchless materials and overall sophistication that define your experience when riding in it. Genuine wood inlays, evocative ambient lighting, handcrafted finish throughout—all create an exclusive atmosphere for a singular sanctuary.



.11 - Executive Rear Seating

The available A8 L Executive Rear Seat Comfort package adds a level of personalized comfort to the benchmark in executive luxury. Power rear single seats with massage function immerse you in sumptuous relaxation, while a fixed, leather-covered rear center console and Rear Seat Entertainment system with dual 10" screens create a mobile business or pleasure center. This package also features a small refrigerator between the rear seats as well as rear-seat ventilation.



.12 - Power Rear Side Sunshades

Enjoy your right to privacy in the A8 L with power rear side sunshades that also help block out uncomfortable heat and glare.



.13 - Panoramic Sunroof

The optional two-panel panoramic sunroof offers both the front and rear passengers an unobstructed view overhead while flooding the cabin with natural light. And when you decide you need to say goodbye to the sun, the power sunshades are there to make it an easy task.



.14 - Rear Seat Entertainment

With vibrant dual 10" screens, the available Rear Seat Entertainment option can display a wealth of media choices and information, including navigation. Each rear seat occupant can access their own media controls located on the center armrest.

quattro

It's a bond between your car and the road.

It's true that while the Audi quattro® all-wheel drive may have been engineered to help drive through inclement weather and in low-traction situations, the real magic of this advanced system is how it performs in the dry. Power is distributed to all four wheels working in concert to help grip every corner while giving you the optimal amount of power delivery where and when it's needed. In other words, quattro® helps enhance performance by appropriately transferring power to the necessary wheels when accelerating and turning, so you have confidence-inspiring performance when the road isn't at its best. Inclement weather aside, the really gripping story about quattro® is how it performs overall, forging a sure bond between you, your Audi A8 and the road.¹

Confidence-inspiring

Under ideal conditions, power is 40:60 rear-wheel-biased to help maximize acceleration and cornering, but the instant conditions become more challenging, the ratio is optimized for superior grip and control.

Sports differential

Adding yet another level of handling, the available sports differential sends power to the outside rear wheel, helping to push the car through the turn, giving you confidence to take on some of the most challenging mountain roads.

Torque split

When accelerating out of a turn, up to 80% of the power is mechanically shifted to the rear wheels, where it's best allocated to propel the vehicle to your desired speed and onto the straightaway. Once traveling in a straight line again, the 40:60 power distribution that quattro® delivers to the front and rear wheels, respectively, gives you maximum torque to push onward.

Torque vectoring

It's a handling feature that seems to respond to your impulses before your steering input. An evolution of cross-axle lock, this system works within Audi quattro®, while utilizing ESC and ABS to help sense traction loss from the inside cornering tire.

¹ When driving during cold, rainy, snowy or icy weather conditions, ensure that your vehicle is equipped with appropriate all-season or winter-weather tires. Even with appropriate tires, you must always drive in a manner appropriate for the weather, visibility and road conditions.

Harmony begins with balance.

There are moments when everything feels in perfect sync. You make the green lights. The traffic opens up and the highway is yours. The local road with the sharp turns seems to bend to your will. The next time that happens, notice the driving dynamics of your Audi A8—you'll find that all the systems are in equilibrium, engineered for you to take full advantage of the conditions and to produce a drive that is powerful, exhilarating and balanced. Audi engineers tuned the driving dynamics of the A8 to react to a variety of external forces, all focused on one result: producing the kind of personally adjustable ride and handling that makes a driver want to immediately get behind the wheel again.



- *Comfort mode*

Perfect for less-than-perfect roads, this setting adds optimized steering, suspension and transmission shifting to help provide a more relaxed drive.



- *Dynamic mode*

More precise steering, a more responsive throttle and taut sports suspension give this setting an aggressive feel and focused performance.



- *Auto mode*

The best of both worlds, dialed to automatically adjust settings for a seamless combination of comfort and responsiveness, based on your driving style and road conditions.



- *Individual mode*

Take the turn your way—this mode allows you to adjust the steering, suspension, throttle and transmission upshifts to your style.

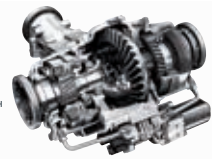

.15 - *Sports Differential*

The overdriven gearing in this optional rear differential rotates 10% faster than the driveshaft. When turning into or accelerating within a curve, the majority of the torque is seamlessly directed to the outside wheel, helping to push the car through the curve.



.16 - *Audi Adaptive Air Suspension*

Through air suspension and a continuously variable, electronically controlled damper system, Audi adaptive air suspension automatically optimizes load distribution and senses driving conditions, to produce a balanced, comfortable and dynamic drive.



quattro®

transmission

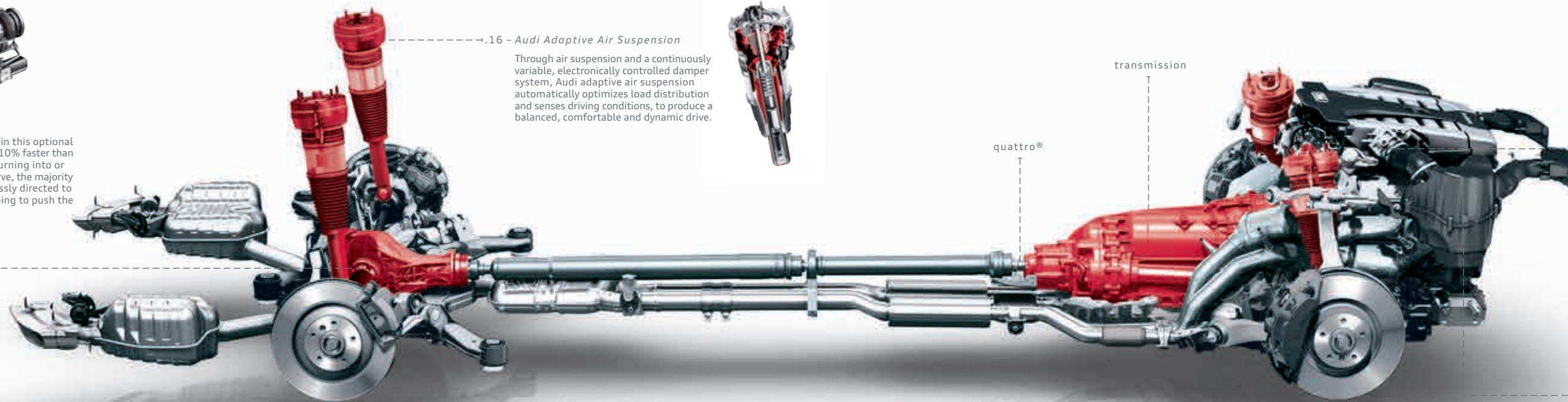

engine

.17 - *Audi Drive Select*

Exclusive to Audi, this system provides advanced control of the vehicle's adaptive suspension, transmission shift characteristics, engine response, optional dynamic steering, and sports differential. It offers distinct driving configurations, allowing drivers to configure vehicle drive characteristics to their liking with the choice of Comfort, Dynamic, Auto or Individual settings.

The new law of demand and supply.

It might seem like we work unceasingly to deliver innovative luxury performance, but even Audi engineers believe in a little downtime. Well, in a manner of speaking. That's why we did something unexpected in our 4.0 TFSI® biturbo V8—by adapting to your drive, we let some of our cylinders take a little break. Our Cylinder on Demand™ engine efficiency technology allows the A8 to operate with only four cylinders when the driving situation doesn't require all eight. When you need the power of all eight cylinders, they are there, automatically and instantaneously. When traffic slows to a halt, or you're the only one on the road, smart technologies help save fuel that doesn't need to be burned.¹

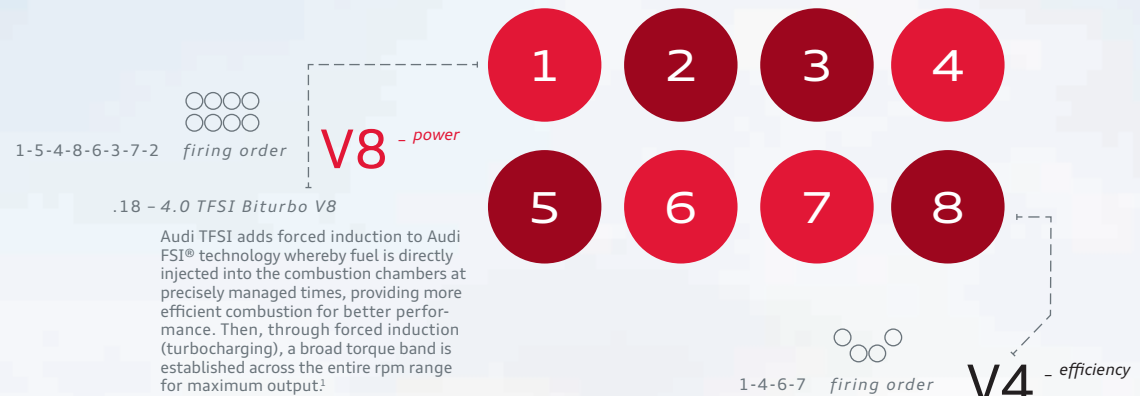

.18 - 4.0 TFSI Biturbo V8

Audi TFSI adds forced induction to Audi FSI® technology whereby fuel is directly injected into the combustion chambers at precisely managed times, providing more efficient combustion for better performance. Then, through forced induction (turbocharging), a broad torque band is established across the entire rpm range for maximum output.¹

.19 - Cylinder on Demand

The Audi A8 4.0T with Cylinder on Demand engine efficiency technology helps make your exciting driving experience more efficient. When they're not needed, four of the eight cylinders stop firing, to save fuel, and seamlessly reignite when the drive requires all eight.¹

A radical shift from convention

The Audi A8 features an eight-speed Tiptronic® automatic transmission, a technical tour de force combining a range of ratios to match whatever the road throws at you. This wide spread of ratios between first and eighth gear not only helps reduce fuel consumption, but is flexible enough to deliver everything from sporty acceleration to smooth cruising.¹

.20 - Eight-speed Tiptronic®

This eight-speed Tiptronic® automatic transmission helps provide impressive fuel efficiency due to its shift versatility. And with the top two gears helping deliver more efficient highway cruising, it is a perfect companion for almost any road trip.¹

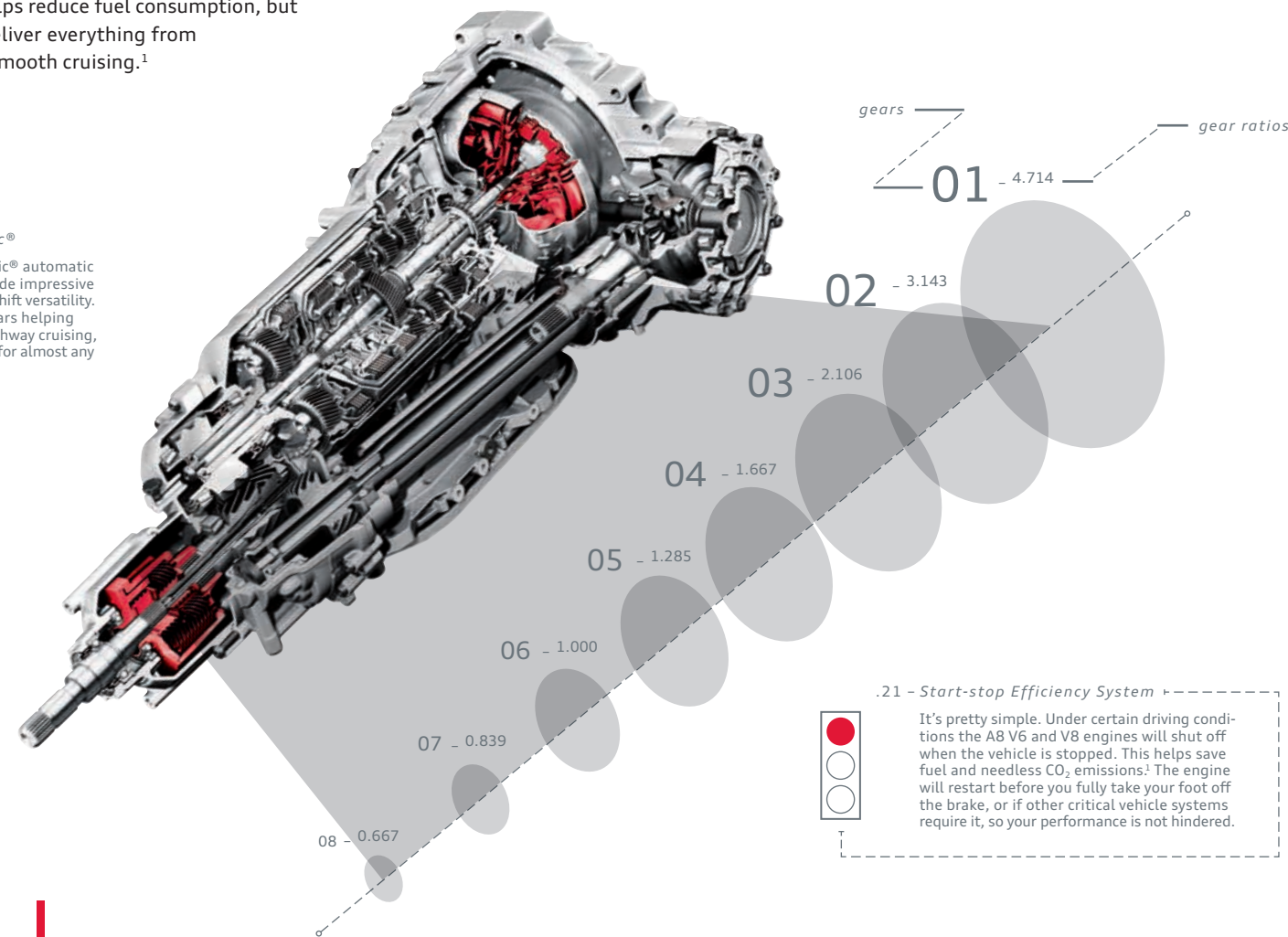

.21 - Start-stop Efficiency System



It's pretty simple. Under certain driving conditions the A8 V6 and V8 engines will shut off when the vehicle is stopped. This helps save fuel and needless CO₂ emissions! The engine will restart before you fully take your foot off the brake, or if other critical vehicle systems require it, so your performance is not hindered.

¹ EPA estimates not available at time of printing. Your mileage will vary.



Suddenly discovering the sizzling side of efficiency.

When it comes to engines, luxury performance has often meant excess—big engines, awash in displacement statistics, obsessed with the number of horses they spit out. Sure, numbers matter, but Audi would like to give you a different perspective, with more-efficient engines that will really surprise you.¹ New for 2013, the A8 features a supercharged 3.0-liter TFSI® V6 that expresses itself powerfully off the line and accelerates just as quickly as vehicles with larger engines² And with a lighter engine, even handling is improved due to less weight on the front axle. If efficiency doesn't hint of performance, consider how the 3.0-liter TFSI engine is capable of producing 333 hp and an inspiring 325 lb-ft of torque. In essence, we've taught excess and efficiency to learn to love how they make each other feel. But the most important part of progressive luxury is putting you in charge of what you drive.



.22 – 3.0 TFSI V6

The 3.0-liter TFSI V6 is the first of its kind in the U.S.-market Audi A8. Along with all the luxury you want from a flagship sedan, this engine and the ASF® aluminum space frame give you weight- and fuel-savings you wouldn't expect, which, in turn, gives you the kind of performance you should.¹



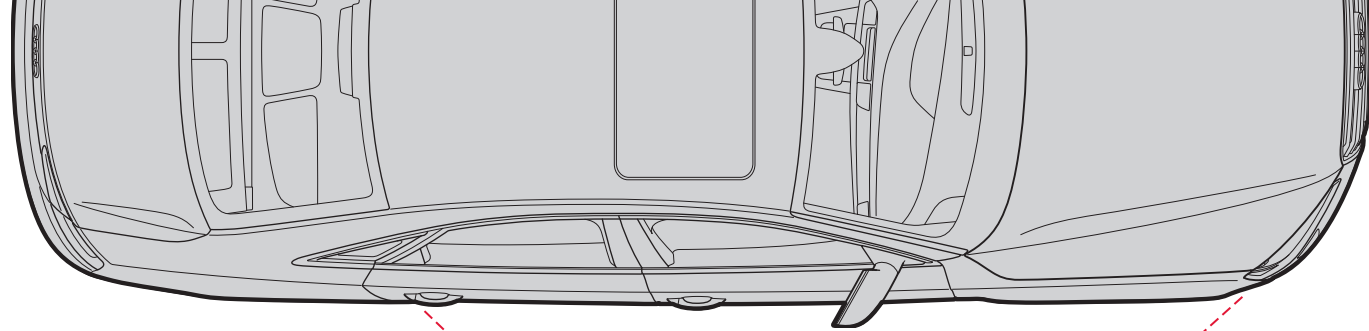

.24 - Night Vision Assistant



With an infrared camera detecting what lies ahead, this available feature uses thermal-imaging technology to help you avoid trouble. Pedestrians can be detected over 300 feet in front of the vehicle, while objects can be detected over 900 feet ahead—all shown on the 7" color driver information system.

.25 - Top and Corner View Cameras



Four cameras on this available technology allow for an overhead view of your surroundings, making parking just a little easier. The technology shows you where your vehicle is in relation to obstacles nearby, giving you the confidence to maneuver in practically any environment.

.23 - Audi Side Assist

The available Audi side assist uses radar sensors and two different optical warnings to help keep the driver informed of what is approaching from hard-to-see angles behind and to the side of the vehicle.

Anticipating needs you didn't know you had.

The suite of available driver-assistance technologies takes into account the actions of other drivers—while making your drive a little easier. From seemingly sentient Audi adaptive cruise control with stop & go to Audi side assist, the Audi A8 has incorporated innovative, anticipatory technologies that don't see your future so much as help change it.

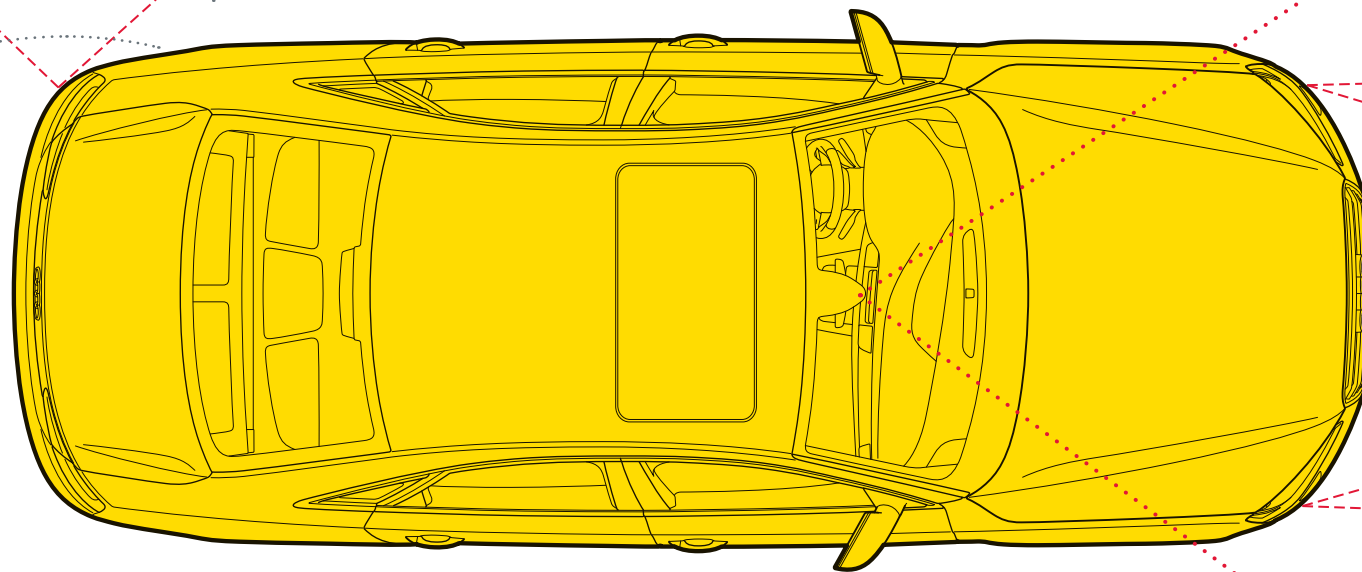

.26 - Audi Pre Sense Plus

The available Audi pre sense plus offers comprehensive driving assistance with sensors in the front, side and rear. After visual, physical and aural collision warnings, there are four distinct phases for automatic preparation for the unavoidable: an upsurge of brake pressure, safety belt pre-tensioning, partial braking, and sunroof and window preparation. In severe cases, Audi pre sense plus will engage full braking and deceleration.

.27 - Audi Adaptive Cruise Control with Stop & Go

Not only retains a preset distance from vehicles ahead, but resumes acceleration when you're ready. Using long-range radar and a camera, the available Audi adaptive cruise control with stop & go helps read the traffic conditions and adjusts the speed, helping to bring the vehicle to a full stop before accelerating when traffic flow resumes.

.28 - Audi Lane Assist

Unlike road-detection systems that override a driver's decision-making process, the available Audi lane assist helps warn of errant steering with a simple vibration on the steering wheel, thus trusting the human element to make the correct on-road decision.

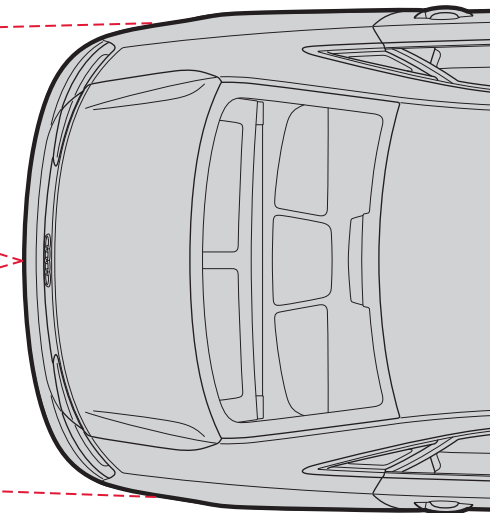

Shedding the excess of old luxury.

When you think of luxury, you probably don't think about weight savings. But by placing the right material where it is most needed, our team of engineers gets to the literal core of a better performing, more efficient,¹ and patently unique luxury vehicle.

.30 - ASF® Aluminum Space Frame

Lightweight yet unyielding, revolutionary ASF® technology offers an innovative approach to weight savings—a benefit you will notice in the overall efficiency,¹ enhanced performance and remarkable handling of the Audi A8. These unique characteristics also help to absorb the normal bumps of the road, delivering a smoother ride.

.29 - Passive Safety

Referring to all dedicated measures that help protect the vehicle's occupants against injury, the passive safety measures in the A8 include its safety belt system, ten airbags,² the rigid occupant cell and crumple zones at the front and rear of the vehicle.

- 02 driver's head airbag
- 02 driver's knee airbag
- 03 driver-side seat-mounted thorax side airbag
- 02 driver-side Sideguard® head curtain airbag for both rows of seats
- 05 driver-side rear seat-mounted thorax side airbag
- 06 front-passenger head airbag
- 07 front-passenger knee airbag
- 08 front-passenger seat-mounted thorax side airbag
- 09 passenger-side Sideguard® head curtain airbag for both rows of seats
- 10 passenger-side rear seat-mounted thorax side airbag

.31 - Ten Airbags

The A8 is equipped with a full complement of ten airbags to offer additional protection in the event of a collision. Head airbags for both driver and front passenger are designed to specifically target and protect the head during collisions, for added protection.²

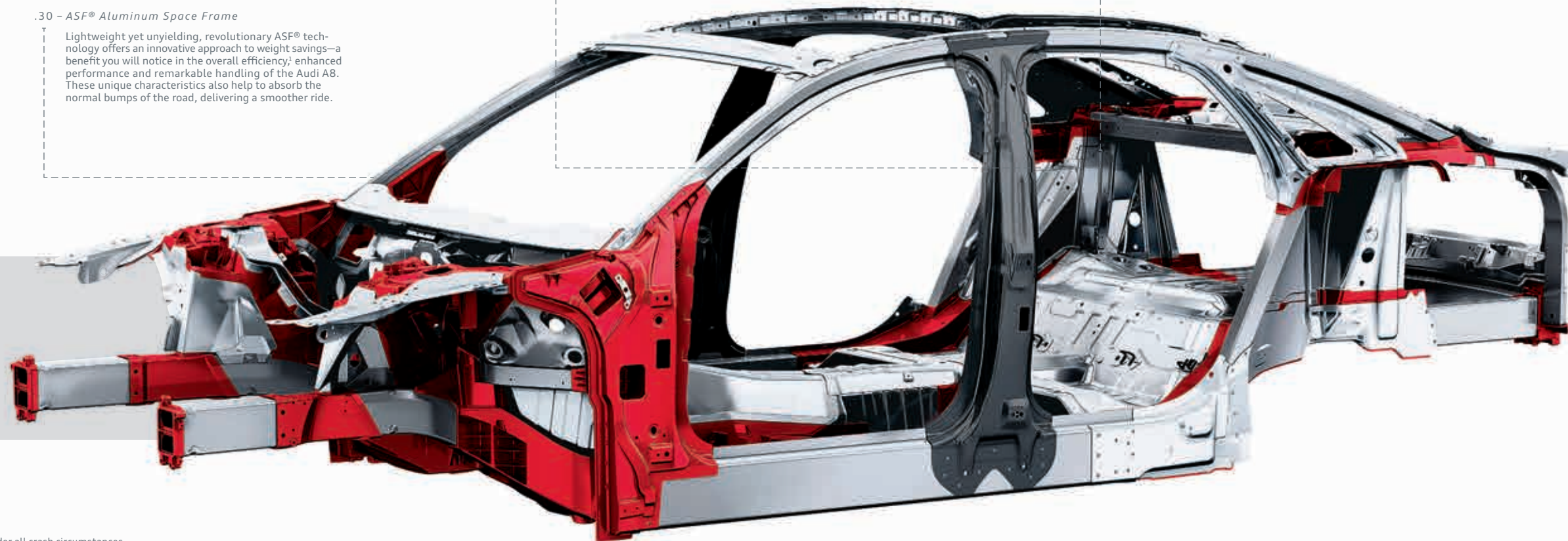

¹ EPA estimates. Your mileage may vary. See www.fueleconomy.gov for details. ² Airbags are supplemental restraints only and will not deploy under all crash circumstances. Always use safety belts and seat children only in the rear, using restraint systems appropriate for their size and age.

Input as unique as your fingerprint.

What does your handwriting say about you? We aren't really sure. We just know it speaks to us. A revolution in intelligent simplicity, the Audi MMI® touch with handwriting recognition is a technology that gives you the ability to give commands and retrieve media simply by recognizing a few strokes of your finger. Access information such as songs, phone numbers, and destinations through the Audi MMI touch—or give input to the optional Audi connect™, the world's first media system with Google Earth™ mapping service. The world isn't simply at your fingertips—your fingertips open up a new way to interact with the world.

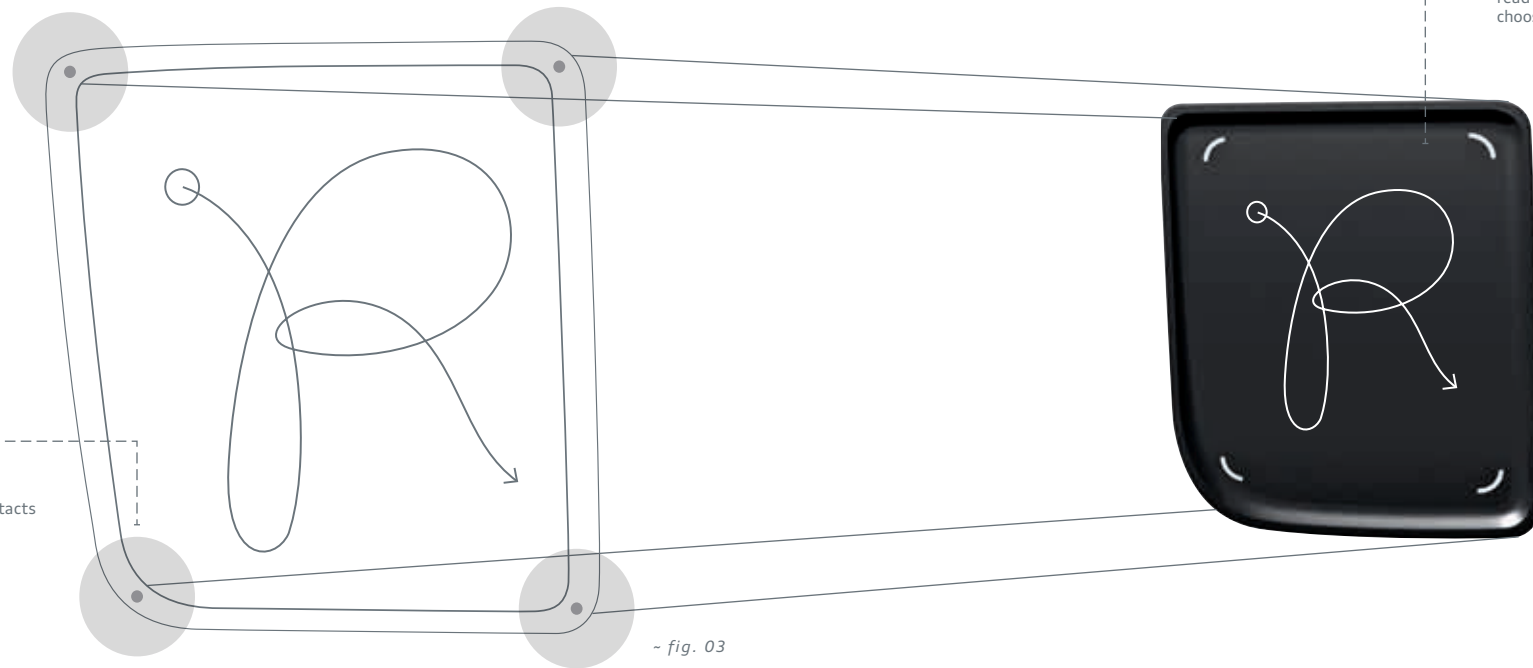

- ▶ letter and number entries for destinations and contacts
- ▶ radio preset selection
- ▶ album-cover scrolling
- ▶ map scrolling
- ▶ sound distribution adjustment

- fig. 03

.32 - Audi MMI Touch

Developed by the Audi Human Machine Interface (HMI) team, Audi MMI touch illustrates why making something simple to use can be so complex. The HMI team built a system so advanced, it can read almost anyone's handwriting—even if you choose to write with your non-dominant hand.



No one connects you the way we do.



38° 57' 8.1" N

77° 23' 41.1" W



Google Earth™ 3D satellite imagery

With Google Earth™ integration, you'll enjoy 3D topography, including Google Maps Street View, displayed right on the Audi MMI® screen.

SiriusXM Traffic

Working with your Google Earth™ overlay, you can get traffic conditions and plan alternate routes to help get around traffic backups?

Reported local fuel prices

Find the lowest reported local price for fuel—and the directions to the station—right through the MMI system.

Google™ Local Search

Search for destinations via text or voice, using the cloud processing power of Google™ speech recognition and their point-of-interest database.

myAudi features

Plan your destination from your personal computer and send your route to your A8, for a preprogrammed trip plan.

Weather information

Current local conditions and forecasts for your destination can help you prepare for your trip.

News feeds

Stay on top of the news by having headlines and stories delivered right to your MMI display.

Mobile Wi-Fi hotspot

Provides high-speed connectivity for up to eight passenger devices through an onboard wireless hub.

We set out to change how people interact in and out of their automobiles. A suite of technologies has made the Audi A8 a true champion of progress. And with Audi connect™ with Google Earth™ imagery and Wi-Fi connectivity for up to eight passenger devices, you have multiple ways to stay connected.¹ You can also access information and navigate entirely with your voice in just a few commands. With that kind of access, Audi helps build on your interactive life while helping enhance your ownership experience.

33° 46' 3.1" N

118° 11' 26.5" W

¹ Distracted driving can cause a loss of vehicle control. The features and technologies discussed above are offered for convenience, and should be used only when it is safe and appropriate. The Wi-Fi hotspot feature is intended for passenger use only. Always pay careful attention to the road, and do not drive while distracted. Features may require additional subscription plan. See dealer for details. ² See back cover for important information regarding required SiriusXM subscriptions.



The sounds of music.

For years, while other sound-system engineers were obsessed with what they thought you should be hearing, Audi sound engineers thought about how we impact what people are feeling when they are enjoying music. We found a partner who shared our passion—Bang & Olufsen®—who has helped us conceive a new way of experiencing sounds in your A8. We use speaker positioning, speaker design and precise sound calibration to work in concert with the ambient noise in your car. The results are crisper, more resonant—you might even say, more emotional. Because, if you are only listening, you're not really feeling it.¹



(Bang & Olufsen® acoustic lenses)

19 speakers

.33 - ICEpower® Amplifiers

About the size of a smartphone, this revolutionary acoustic technology from Bang & Olufsen® helps ensure a powerful sound base without taking up the amount of space or emitting the level of heat that conventional amplifiers do. No wonder Bang & Olufsen® and Audi complement each other so well.¹



.34 - Bang & Olufsen® Advanced Sound System

The passion of Bang & Olufsen® matches well with Audi. By focusing on design and performance together, we bring out the best in outstanding acoustics. Bang & Olufsen® engineers help to sculpt meticulously rendered sound through two innovative retractable aluminum acoustic lenses and an impressive 1,400 watts of pure power!¹

1,400 watts



(2 of 19 speakers)



¹ Standard text and data usage rates apply.

¹ Bang & Olufsen® Advanced Sound System available on all A8 models.



.35 - LED Taillight Technology



- fig. 04

LEDs are amongst the most luminous taillights available. And, like Audi vehicles, they are efficient, technologically advanced, and long-lasting.

We bid you adieu.

It's good to say goodbye with style, and that's the only way Audi does it. Our flagship Audi A8 exemplifies supreme luxury from headlights to taillights. We haven't left anything to the imagination, and have insisted on incorporating only the most brilliant features throughout the A8. Attention to every detail inspired us to design LED lighting technology into the taillights, as we did with the optional full LED headlights, to make a bold statement whether coming or going. The LED taillight technology lasts longer, saves energy, and illuminates faster to make sure that whoever is behind will know more quickly when things are slowing down. Everyone knows when an Audi is approaching—it's also clear when one is passing.

2013 Audi A8 L 4.0T shown in Phantom Black pearl.

Exterior Colors

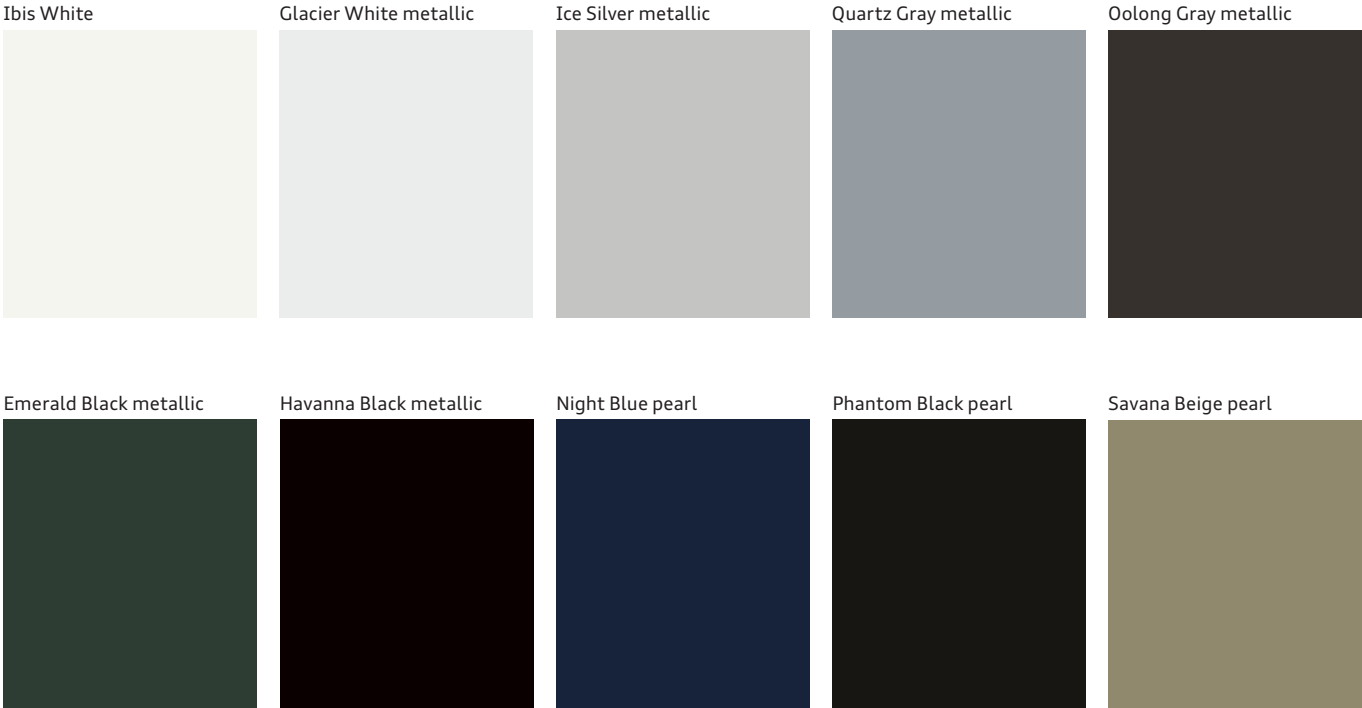

Interior Colors | Seat Selections



Audi design selection

Interior leathers are available in Valetta, Valcona or Fine Nappa grains. Each offers the comfort, quality, and craftsmanship you would expect from Audi. Not all leather colors are available in all grains. Available Extended Leather package features leather center console, door armrests and pulls, knee rests and airbag cap on 3.0T and 4.0T models. On W12, available Full Leather package features Fine Nappa upholstery, including leather upper and lower instrument panel, center console, door trim (including armrests), knee rests and airbag cap. See your dealer for details.

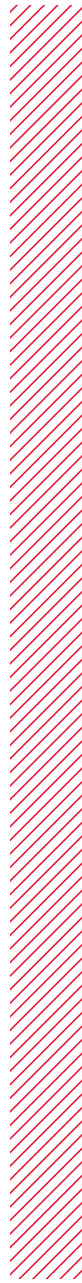

Decorative Inlays



Upper Decorative Inlay Options¹

Brown Walnut Wood inlay

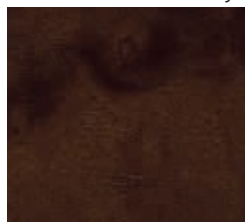

Pearl Beige Fine Grain Birch Wood inlay

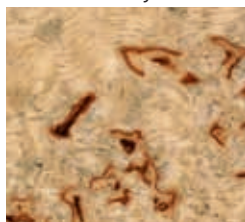

Assam Gray Vavona Wood inlay

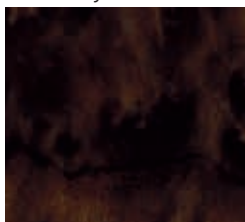

Balsamic Brown Natural Fine Grain Ash Wood inlay



Piano Black Wood inlay

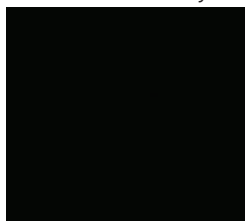

Velvet Brown Fine Grain Ash Wood inlay

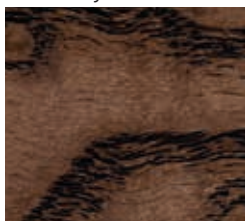

Lower Decorative Inlay Options¹

Brushed Aluminum inlay



High-polished Black inlay

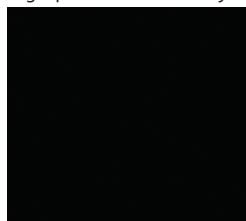

Wheels

19" 10-Y-spoke design
255/45 all-season tires



A8 3.0T (standard)

19" 15-spoke design
255/45 all-season tires



A8 4.0T (standard)
A8 L W12 (optional)

20" 10-parallel-spoke design
265/40 all-season tires²



A8 L W12 (standard)
A8 3.0T and 4.0T (optional)

20" 5-segment-spoke design
265/40 all-season tires²



Sport design package and
Sport plus package³

¹ Decorative inlay options will vary based on model and interior color combination. See your dealer for details.

² Tires are supplied and warranted by their manufacturer. High-performance tires are designed for optimum performance and handling in warm climates. They are not suitable for cold, snowy, or icy weather conditions. If you drive under those circumstances, you should equip your vehicle with all-season or winter tires, which offer better traction under those conditions. We suggest you use the recommended winter or all-season tire specified for your car or its equivalent. These high-performance tires also have a lower aspect ratio that aids performance and handling; however, in order to avoid tire, rim or vehicle damage, it is important that the inflation pressure is regularly checked and maintained at optimum levels. Please also remember in making your selection that, while these tires deliver responsive handling, they may ride less comfortably and make more noise than other choices. Finally, these tires may wear more quickly than other choices. ³ Sport plus package comes equipped with 265/40 summer performance tires.

Technical Specifications

Engineering | Performance

	A8 3.0T	A8 4.0T	A8 W12
Engine type	Six-cylinder	Eight-cylinder	Twelve-cylinder
Engine block/Cylinder head	Aluminum-alloy	Aluminum-alloy	Aluminum-alloy
Displacement (cc)/Bore and stroke (mm)	2,995/84.5 x 89.5	3,991/84.5 x 89.5	6,299/86.1 x 90.4
Horsepower (@ rpm)	333 @ 5,500	420 @ 5,000	500 @ 6,200
Torque (lb-ft @ rpm)	325 @ 2,900	444 @ 1,500	463 @ 4,750
Compression ratio	10.3:1	10.1:1	11.8:1
Valvetrain	24-valve DOHC	32-valve DOHC	48-valve DOHC
Induction/Fuel injection	Supercharged/TFSI®	Turbocharged/TFSI®	FSI®
Cylinder-on-Demand™ engine efficiency technology	—	■	—
Start-stop efficiency system	■	■	—
Acceleration with Tiptronic® transmission (0–60 mph, NWB/LWB)	5.5 seconds	4.7/4.8 seconds	4.4 seconds
Top track speed ¹	130	130	130

Transmission | Drivetrain

Eight-speed Tiptronic® automatic transmission with Audi quattro® all-wheel drive	■	■	■
Gear ratios: 1st: 4.714, 2nd: 3.143, 3rd: 2.106, 4th: 1.667, 5th: 1.285, 6th: 1.000, 7th: 0.839, 8th: 0.667, Reverse: 3.317, Final Drive: 3.204	■	■	—
Gear ratios: 1st: 4.714, 2nd: 3.143, 3rd: 2.106, 4th: 1.667, 5th: 1.285, 6th: 1.000, 7th: 0.839, 8th: 0.667, Reverse: 3.317, Final Drive: 3.076	—	—	■

Body | Suspension | Chassis

Audi ultra® lightweight technology—ASF® aluminum space frame	■	■	■
Five-link front suspension	■	■	■
Trapezoidal-link rear suspension	■	■	■
Audi adaptive air suspension	■	■	■
Audi adaptive air suspension—sport	SP	SP	SP
Audi servotronic® power steering system	■	■	■
Dynamic steering	SP	SP	■
Sports differential	SP	SP	SP

■ Standard	NA Information not available at time of printing	CA Camera Assistance package	CF Comfort package	CP Convenience package	CW Cold Weather package	DA Driver Assistance package
— Not applicable		ER Executive Rear Seat Comfort package	RS Rear Seat Comfort package	SD Sport design package	SP Sport plus package	WW Warm Weather package

Exterior measurements

	A8 3.0T	A8 4.0T	A8 W12
Wheelbase, NWB (in)	117.8	117.8	—
Wheelbase, LWB (in)	122.9	122.9	122.9
Length, NWB (in)	202.2	202.2	—
Length, LWB (in)	207.4	207.4	207.4
Height, NWB (in)	57.5	57.5	—
Height, LWB (in)	57.9	57.9	57.9
Overall width with mirrors (in)	83.1	83.1	83.1
Overall width without mirrors (in)	76.7	76.7	76.7
Track, front/rear (in)	64.7/64.4	64.7/64.4	64.7/64.4
Curb weight with Tiptronic® transmission (lb), NWB/LWB	4,376/4,409	4,531/4,597	4,773
Drag coefficient (Cw)	0.26	0.27	0.27

Interior measurements

Head room with sunroof, NWB (in, front/rear)	37.2/38.1	37.2/38.1	—
Head room with sunroof, LWB (in, front/rear)	37.2/39.1	37.2/39.1	37.2/39.1
Leg room, NWB (in, front/rear)	41.4/38.7	41.4/38.7	—
Leg room, LWB (in, front/rear)	41.4/42.9	41.4/42.9	41.4/42.9
Shoulder room (in, front/rear)	59.1/57.8	59.1/57.8	59.1/57.8
Cargo volume (cu ft)	13.2	13.2	13.2
Passenger volume, NWB (cu ft)	115.1	115.1	115.1
Passenger volume, LWB (cu ft)	121.9	121.9	121.9
Seating capacity, standard/optional	5/—	4/5	4/5

EPA mileage estimates | Capacities

Tiptronic® automatic transmission (city/highway/combined)	18/28/21	NA ²	NA ²
Engine oil (qt)	7.2	8.7	12.2
Fuel (gal)	23.8	23.8	23.8
Recommended fuel	Premium	Premium	Premium

¹ Top track speed is electronically limited in the U.S. Obey all speed and traffic laws. ² EPA estimates not available at time of printing. Your mileage will vary.

Featured Content

Safety Security	A8 3.0T	A8 4.0T	A8 W12
Driver and front passenger dual-stage airbags, thorax side airbags, knee airbags, and Sideguard® head curtain airbags ¹	■	■	■
Rear-passenger thorax side airbags ¹	■	■	■
Front passenger occupant detection—for airbags ¹	■	■	■
Safety belt reminder for driver and front passenger	■	■	■
Lower Anchors and Tethers for CHildren (LATCH) in rear seats	■	■	■
Power central locking system with safety unlock feature if airbags deploy	■	■	■
Electronic Stability Control (ESC) with traction control (ASR)	■	■	■
Anti-lock Brake System (ABS) with Electronic Brake-pressure Distribution (EBD) and brake assist	■	■	■
Tire-pressure monitoring system	■	■	■
Electromechanical parking brake	■	■	■

Exterior	A8 3.0T	A8 4.0T	A8 W12
Audi Singleframe® grille	■	■	■
Adaptive xenon plus headlights with LED daytime running light technology	■	■	—
Full LED headlight technology	Optional	Optional	■
High-beam assistant	CA	CA	■
Headlight washing system	■	■	■
Automatic headlights	■	■	■
LED taillight technology and rear fog lights	■	■	■
Power-adjustable, power-folding, auto-dimming, heated exterior side mirrors with memory	■	■	■
LED turn indicator light technology integrated into the exterior side mirrors	■	■	■
LED puddle lighting technology	■	■	■
Heated windshield washer nozzles	■	■	■
Aluminum trim around exterior windows	■	■	■
Power soft-closing doors, NWB/LWB	CP/■	CP/■	■
Power trunk open/close and hands-free release, NWB/LWB	CP/■	CP/■	■
Dual exhaust outlets	■	—	—
Integrated twin-trapezoidal exhaust outlets	—	■	■

■ Standard	NA Information not available at time of printing	CA Camera Assistance package	CF Comfort package	CP Convenience package	CW Cold Weather package	DA Driver Assistance package
— Not applicable		ER Executive Rear Seat Comfort package	RS Rear Seat Comfort package	SD Sport design package	SP Sport plus package	WW Warm Weather package

Interior	A8 3.0T	A8 4.0T	A8 W12
Dual-zone automatic climate control	■	■	—
Four-zone automatic climate control, NWB/LWB	WW/■	WW/■	■
Four-spoke multifunction steering wheel with shift paddles	■	■	■
Heated steering wheel	CW	CW	■
Power tilt and telescopic steering column with memory	■	■	■
Decorative interior inlays (see Decorative Inlays page)	■	■	■
Alcantara® headliner (light or black option)	Optional	Optional	■
Power windows with one-touch up/down operation and pinch protection	■	■	■
Dual-pane acoustic glass	Optional	Optional	■
Power rear side sunshades, NWB/LWB	WW/■	WW/■	■
Power rear sunshade, NWB/LWB	■	■	■
Panoramic sunroof (not available on NWB)	Optional	Optional	■
Sunroof (solar power integration optional)	■	■	Optional

Seating	A8 3.0T	A8 4.0T	A8 W12
Leather seating surfaces (see Interior Fabrics page for more details)	■	■	■
18-way power front seats, including power lumbar adjustment and memory	■	■	—
22-way power comfort front seats, including power lumbar adjustment and memory	CF	CF	■
22-way power sport comfort front seats, including power lumbar adjustment, memory, and diamond-stitched pattern	SD	SD	SD
Heated front seats	■	■	■
Ventilated front seats with massage function	CF/SD	CF/SD	■
Power rear seats with power lumbar adjustment (not available on NWB)	RS	RS	Optional
Power rear single seats with power lumbar adjustment, memory, and fixed center console (not available on NWB)	—	ER	■
Heated rear seats	CW	CW	■
Ventilated rear seats with massage function (not available on NWB)	—	ER	■
Passenger-side rear relaxation seat with power footrest (eliminates front passenger seat massage function and limits front passenger seat to 10-way power adjustment; not available on NWB)	—	ER	ER
Refrigerator in center pass-through (10.4-liter capacity, eliminates rear seat pass-through with ski bag; not available on NWB)	—	ER	ER
Front and rear comfort headrests	■	■	■
Rear seat pass-through with ski bag	CW	CW	■

¹ Airbags are supplemental restraints only and will not deploy under all crash circumstances. Always use safety belts and seat children only in the rear, using restraint systems appropriate for their size and age.

Featured Content

Infotainment Technology	A8 3.0T	A8 4.0T	A8 W12
Audi MMI® Navigation plus with voice control system ¹	■	■	■
Audi MMI® touch with handwriting-recognition technology ¹	■	■	■
Audi connect™ with six-month trial subscription ¹	■	■	■
7" color driver information system	■	■	■
BOSE® Surround Sound system with 14 speakers, AudioPilot®, and 630 watts	■	■	■
Bang and Olufsen® Advanced Sound System with 19 speakers and 1,400 watts	Optional	Optional	Optional
HD Radio™ Technology	■	■	■
SiriusXM Traffic with four-year subscription ²	■	■	■
SiriusXM Satellite Radio with 90-day trial subscription ²	■	■	■
Audi music interface with iPod® integration	■	■	■
In-dash DVD player	■	■	■
Rear Seat Entertainment with dual 10" screens and DVD single slot, NWB/LWB	Optional	Optional/ER	■
BLUETOOTH® wireless technology preparation for mobile phone	■	■	■
Garage door opener (HomeLink®)	■	■	■
Keyless Start	■	■	■
Audi advanced key (keyless start, stop and entry) ³ , NWB/LWB	CP/■	CP/■	■
Audi adaptive cruise control with stop & go	DA	DA	DA
Audi lane assist and Audi side assist	DA	DA	DA
Audi pre sense plus—including Audi pre sense rear	DA	DA	DA
Night vision assistant with pedestrian detection	Optional	Optional	Optional
Audi drive select	■	■	■
Parking system plus (includes rear view camera and front/rear sensors), NWB/LWB	CP/■	CP/■	■
Top and corner view camera system	CA	CA	■

- Standard
- Not applicable
- NA Information not available at time of printing
- CA Camera Assistance package
- ER Executive Rear Seat Comfort package
- CF Comfort package
- RS Rear Seat Comfort package
- CP Convenience package
- SD Sport design package
- CW Cold Weather package
- SP Sport plus package
- DA Driver Assistance package
- WW Warm Weather package

¹ Audi Navigation plus depends on signals from the worldwide Global Positioning Satellite network. The vehicle's electrical system and existing wireless and satellite technologies must be available and operating properly for the system to function. The system is designed to provide you with suggested routes in locating addresses, destinations and other points of interest. Changes in street names, construction zones, traffic flow, points of interest and other road system changes are beyond the control of Audi of America, Inc. Complete detailed mapping of lanes, roads, streets, toll roads, highways, etc., is not possible, therefore you may encounter discrepancies between the mapping and your actual location. Please rely on your individual judgment in determining whether or not to follow a suggested Audi Navigation plus route. Periodically mapping updates will be available for purchase at an additional cost. Consult your dealer or call 1-800-FOR-AUDI for details. ² See back cover for important information regarding required SiriusXM subscriptions. ³ Some Audi models are equipped with a keyless ignition feature. The details as to how the system works can vary and Audi owners should consult their owner's literature or an authorized Audi dealer if they have further questions about the operation of this feature. Please note that Audi warns against leaving the vehicle unattended with the engine running, particularly in enclosed spaces.

It's hard to believe there is something to upgrade.

The only thing that can outdo the Audi A8 is, of course, the A8 with the Audi design selection package. Experience an even deeper sense of luxury with Balao Brown Valcona leather seating surfaces along with Snow White seat stitching and piping. You'll find that this sensuous pairing brings out the depth of the Balsamic Brown Natural Fine Grain Ash Wood upper inlays and contrasts perfectly with the Brushed Aluminum inlays that lie lower. This package, tastefully proclaimed by special badges on the door sills, is available on select Audi A8 models, giving you even more A8 to celebrate.



Balao Brown leather with Balsamic Brown Natural Fine Grain Ash Wood and Brushed Aluminum inlays. Audi design selection.

Accessories

Imagine a cherry on top of your sundae. Sweet, right? Now imagine a cherry that helps protect your A8 in the garage. Or carries your bikes for a serious weekend on the trails. Or makes heads turn as you drive by. Audi Genuine Accessories are the little extras that make your Audi even sweeter. Designed by the same visionaries

who designed your vehicle, all accessories feature a tailored fit and the expert craftsmanship you'd expect from Audi. They are also backed by the 4-year/50,000-mile Audi New Vehicle Limited Warranty or the accessory's 12-month/12,000-mile limited warranty, whichever extends longer from the accessory purchase date.¹



20" Cartesia Alloy Wheel

An elegant, open design with five parabolic arms, each described by one thin and one medium blade. The blades and rim edge are machined to a bright finish, and the remaining surfaces are graced by a rich anthracite tone. Every Audi alloy wheel design is engineered, manufactured and tested to meet rigorous factory and regulatory standards.



Textile Floor Mats

These precision-fit mats are made of long-life fabric to help protect the vehicle's interior from the elements. Skid-resistant. Available in black with silver piping in sets of two for front or rear.



Receptacle

Removable, portable ashtray with lid fits in either of the two front cup holders in the A8.



A8 Base Carrier Bars²

Attached to strong side brackets, these are the durable foundation of the Audi roof-rack system.³



Aluminum Luggage Basket⁴

High-quality anodized-aluminum construction and a generous load area make this an excellent carrier. Side rails help prevent load-shifting. Straps and base carrier bars sold separately.



Splash Protectors

Help protect the vehicle's finish with custom-fit splash protectors. Made of crack-resistant rubber. Available in sets of two for front or rear.

Other accessories not shown — — — —

Audi Genuine Sport and Design Accessories

Your Audi vehicle features a bold, aggressive stance and strong, stunning lines. Enhance it by adding Audi Genuine Sport and Design Accessories. All are carefully scrutinized in the design and development process. So while they're striking in appearance, they've also passed rigorous quality assessments, including corrosion testing. If you're looking for a bolder appearance or a finishing touch, there is a solution designed by Audi that makes every mile more enjoyable—and more yours.

Audi Guard Comfort and Protection Accessories

Protect what you love. Audi Guard Comfort and Protection Accessories offer functional, practical items that help keep your Audi in pristine condition. Choose from such useful items as trunk liners that help make clean-up quick and easy, or an easy-to-use storage cover that helps shield the vehicle. Use them all to help reduce wear and tear and keep the vehicle looking like new—inside and out. All are engineered to stringent Audi standards, so you can be assured of their quality and durability.

Audi Genuine Electronics Accessories

The illuminating technology that graces each Audi vehicle provides the inspiration for Audi Genuine Electronics Accessories. Similarly, all of these accessories are impressively advanced and inspiring. Our audio options let you enhance your listening pleasure. Other accessory options help promote safer, more convenient travel. All are designed and tested to help ensure compatibility with the vehicle's electrical systems, allowing you to enjoy every aspect of Audi technology with almost all your senses. Demand the best and drive with added confidence.

Audi Genuine Alloy Wheels

Strike the perfect balance between breathtaking design and awe-inspiring performance with Audi Genuine Alloy Wheels. Audi experts have meticulously designed these wheels especially for each Audi model. They're engineered to the highest standards and endure rigorous testing to help ensure long-term quality. Experience eye-catching style that is yours and yours alone. Nothing enhances the bold, dynamic look of your Audi vehicle faster.

Audi TravelSpace Transport Accessories

You go almost everywhere. Give your Audi the proper invitation to be part of your adventures. Never leave the necessary gear behind. Bring it with Audi TravelSpace Transport Accessories. The list includes bike racks, ski racks, a variety of watersports equipment carriers and various sizes of cargo carriers. Wherever you go, make sure almost everything fits with a variety of intelligent and innovative solutions. Accessories designed for your life—the passionate, active part.

¹ See dealer for details. ² Base carrier bars are not compatible with the A8 L. ³ All roof-rack system attachments require the base carrier bars. All attachments sold separately. ⁴ Recreational equipment, sporting equipment and luggage not included.

Audi exclusive. Exceptionally yours.



Since the Audi A8 isn't the typical luxury car, we're certain that our drivers are equally unique. And Audi exclusive is an extraordinary opportunity to make your vehicle distinctively yours. You can select luxury finishes and sporty accents with an unmistakably personal touch, choosing from high-grade materials and finishes that will delight all of your senses. Distinctive wood inlays and fine leather surfaces ensure that every millimeter of your vehicle's interior will be exceptional. Without question, Audi exclusive is the superior way to build a car that more intimately reflects your personality and style.





Design without limit.

Countless combinations of fine wood, leathers and color options are available with Audi exclusive. When you build an Audi exclusive A8, you open the door to creating a vehicle unlike any other vehicle on the road. It's very clear that we've taken luxury to the next level. You're in charge. So let your inner creative out, and see how limitless your options are when you take the time to realize a vehicle that is unmistakably yours.



2013 Audi A8 shown in Powder Beige leather with Smokey Blue center seam and Oak Sepia Wood inlay.

Interior Colors

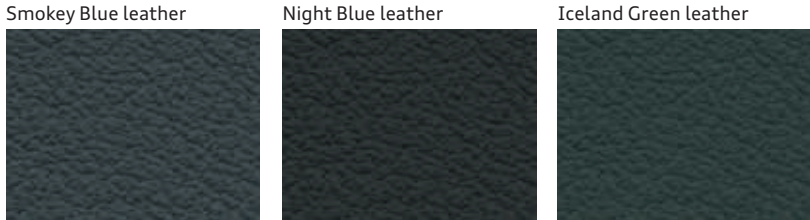

Inlays

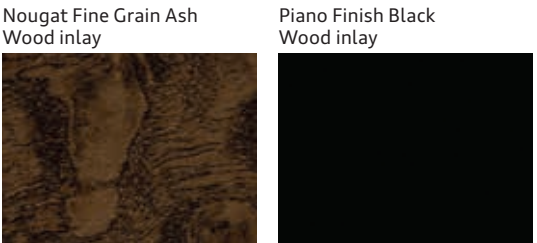
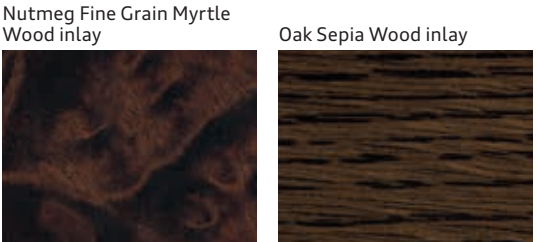

Exterior Colors

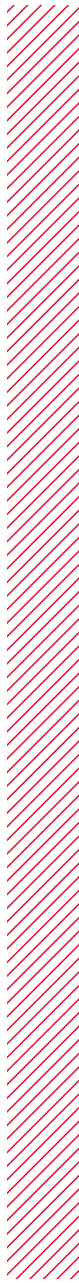
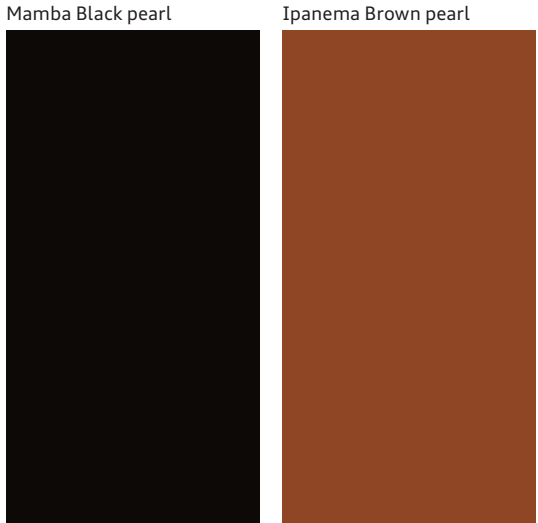
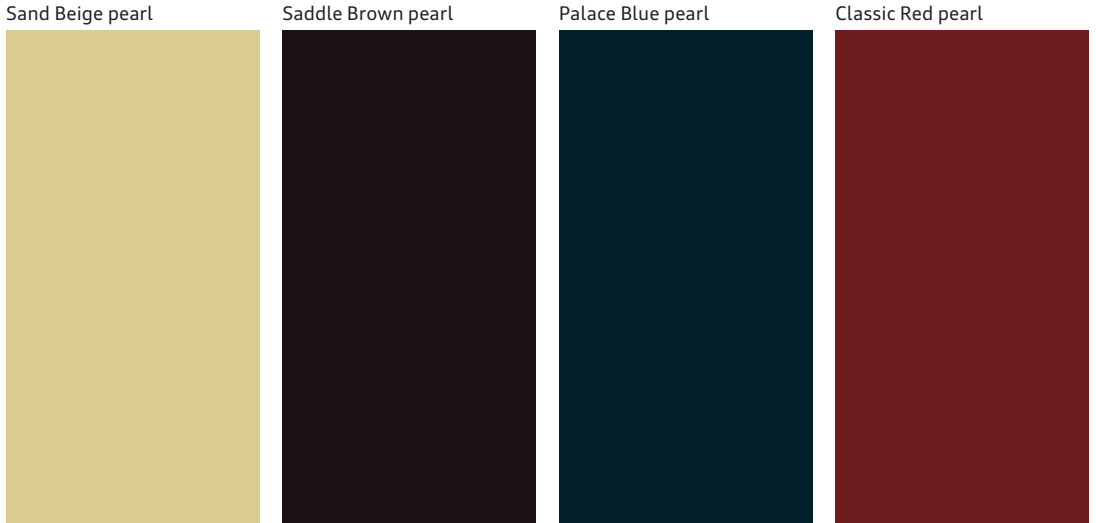

A8

Note: A word about this brochure. Audi of America, Inc., believes the specifications in this brochure to be correct at the time of printing. However, specifications, standard equipment, options, fabrics, and colors are subject to change without notice. Some equipment may be unavailable when your vehicle is built. Please ask your dealer for advice concerning current availability of standard and optional equipment, and your dealer will verify that your vehicle will include the equipment you ordered. Vehicles in this brochure are shown with optional equipment. See your dealer for complete details on the New Vehicle Limited Warranty, twelve-year limited warranty against corrosion perforation, and Audi 24/7 Roadside Assistance. (Roadside assistance coverage provided by Road America in the U.S. Certain conditions apply; see your dealer for details.) Tires supplied by various manufacturers. Audi, all model names, "Audi connect," "ASF," "Cylinder on Demand," "FSI," "MMI," "quattro," "Sideguard," "Singleframe" and the Singleframe grille design, "TFSI," "Truth in Engineering," and the four rings logo are trademarks or registered trademarks of AUDI AG. "Alcantara" is a registered trademark of Alcantara S.p.A. "Bang & Olufsen" is a registered trademark of Bang & Olufsen, The BLUETOOTH word mark and logos are owned by the Bluetooth SIG, Inc., and use of any such marks by AUDI AG is under license. "BOSE" and "AudioPilot" are registered trademarks of the Bose Corporation. "GOOGLE," "Google Earth" and "Google Maps Street View" are trademarks of Google Inc. "HD Radio" and the HD Radio logo are proprietary trademarks of iBiquity Digital Corporation. "Homelink" is a registered trademark of Johnson Controls Technology Company. "ICEpower" is a registered trademark of Bang & Olufsen. "iPod" is a registered trademark of Apple, Inc. "Servotronic" is a registered trademark of the AM General Corporation. "SiriusXM" and all related marks and logos are trademarks of Sirius XM Radio Inc. and its subsidiaries. SiriusXM Satellite Radio and Traffic subscriptions sold separately or as a package after trial expires. SiriusXM Traffic service available in select markets. Subscriptions are governed by SiriusXM Customer Agreement (see www.siriusxm.com) and are continuous until you call SiriusXM to cancel. SiriusXM U.S. Satellite Service available only to those 18 and older in the 48 contiguous U.S.A., D.C. and Puerto Rico (with coverage limitations). "TDI" is a registered trademark of Volkswagen AG. "Tiptronic" is a registered trademark of Dr. Ing h.c. F. Porsche AG. All other trademarks are the property of their respective owners. Some European models shown.

2013 | A8

Audi of America
Audiusa.com
Facebook.com/Audi