

RS Q3



Audi Sport



	Page	
Fascination		
	4	Audi RS Q3
Technology		
	22	Innovations
	24	Audi Sport
	26	Performance
	28	quattro®
	30	Dynamics
	32	Audi drive select
Equipment		
	36	Style guides
	38	Paint finishes
	40	Wheels/tyres
	42	Seats
	43	Headlinings
	44	Inlays
	46	Lights
	46	Design
	47	Steering wheels/controls
	47	Comfort
	49	Infotainment
	51	Assistance systems
	52	Technology/safety
	53	Audi Extended Warranty
Other		
	54	Technical data
	55	Dimensions
	56	Index
	60	The fascination of Audi

The equipment for the vehicle illustrated in the Fascination section can be found on page 59.
 The fuel consumption and CO₂ emission figures can be found on page 54.



Be ready for anything.

■ Pure sportiness with many different facets. Power. Athletic dynamism. And a sensational design. A vehicle that does more than deliver a unique driving experience. It will inspire you, too. The Audi RS Q3.

The fuel consumption and CO₂ emission figures can be found on page 54.



■ Irresistible: from 0 to 100 km/h in just 4.8 seconds. No problem for the 2.5 litre TFSI engine with 250 kW of power. Sporty genes. Five cylinders. A vehicle capable of adapting to particular driving situations or personal preferences, thanks to Audi drive select. Fitted as standard.

The fuel consumption and CO₂ emission figures can be found on page 54.



Live in the fast lane.

▀ The right way to put power where you need it, and without delay: Immediately: the S tronic® dual-clutch transmission enables quick gear changes in a few hundredths of a second. With virtually no break in propulsive power. Increased dynamics on tight bends and long straights. In tight corners, on long straights. The optional RS sport suspension plus with damper control.

The fuel consumption and CO₂ emission figures can be found on page 54.



Go your own way.

▀ Traction that is sportily defined and reliable: this is what quattro stands for. The distribution of drive force to the front and rear wheels as required. And bringing the same self-assuredness to the car's stopping power, there is an 18-inch RS braking system featuring wave brake discs on the front axle.

The fuel consumption and CO₂ emission figures can be found on page 54.





Become a talking point.

Characteristic for the Audi RS Q3: self-assurance. All-round. Audi Singleframe with gloss black honeycomb grille and frame in matt aluminium look. RS bumper, including air inlet duct at front with quattro logo and side flaps. Optional 20-inch 5-twin-spoke V design wheels in matt titanium look, gloss turned finish*. RS exhaust system with large oval tailpipe. Rear edge with RS roof edge spoiler and striking diffuser insert.

*Please note the special information relating to wheels on page 54.
The fuel consumption and CO₂ emission figures can be found on page 54.





Open up new space.

▀ Sportiness. Faithfully reflected in the interior. With sport seats in black Alcantara/leather combination and RS Q3 embossing at the front. A flat-bottomed RS multifunction sport leather steering wheel with shift paddles. Stainless steel pedals. Inlays in exclusive carbon on request. Door sill trims with RS Q3 logo.

The fuel consumption and CO₂ emission figures can be found on page 54.





■ Create more space for yourself. With the partially or fully folding rear seat backrest. And with the reversible luggage compartment floor keeping things clean and the luggage compartment cover keeping items out of sight, an uncluttered look comes as standard.

The fuel consumption and CO₂ emission figures can be found on page 54.





The fuel consumption and CO₂ emission figures can be found on page 54.

Keep on going where others have to stop.

And once you reach your destination, why not continue the adventure? In the Audi RS Q3, the possibilities are endless. Enjoy your freedom.

The fuel consumption and CO₂ emission figures can be found on page 54.



Vorsprung durch Technik.

The world is constantly changing. Technology is advancing at an ever faster pace. And in the process, more and more opportunities are opening up to you – nowhere more so than in the field of mobility. We are playing an instrumental role in shaping this progress with Vorsprung durch Technik. Striving to provide you with technology that enriches your life. Making sure that we don't just satisfy your expectations of mobility both today and in the future, but continue to surpass them.



Audi Sport: technologies from motor racing. Transferred to the road.

Thrilling performance. Whether it's works motorsport, customer racing or our high-performance models – you'll not get such a potent adrenalin rush anywhere else. Audi Sport utilises the expertise gained in motor racing to incorporate innovative technologies to series production. With unrivalled passion – for outstanding dynamism.





Consistent power. Put to consistent use. The TFSI® engine.

Consistent power: the 2.5 litre TFSI engine with 250 kW. The maximum torque of 450 Nm lets you experience spontaneous responsiveness and impressive power delivery over the entire engine speed range. The Audi RS Q3 accelerates from 0 to 100 km/h in just 4.8 seconds. The propulsive power ends at an electronically regulated 250 km/h. In addition to all the sportiness however, the efficiency is also convincing - thanks to the start-stop system and recuperation.

Fascinating sound: the extraordinary ignition sequence of the basic 5-cylinder concept gives the Audi RS Q3 an unmistakeable sound that can be influenced with the RS exhaust valve control. Thus, the engine that has won the "International Engine of the Year Award"* for the fifth year in a row not only impresses in terms of performance, torque and efficiency, but also with its remarkable sound.

Outstanding performance that is achieved in conjunction with the 7-speed S tronic. The dual-clutch transmission consists of two transmission parts and changes gears by switching the power-transmitting clutch. Gear changes are executed precisely, at lightning speed and with virtually no break in propulsive power. For this purpose, S tronic provides the programmes D (Drive) and S (Sport) in automatic mode. The manual mode, in which gears can be actively changed using shift paddles on the steering wheel or by nudging the selector lever, offers even greater driving enjoyment. And at the same time, efficient driving is supported by high efficiency and a seventh gear that has been designed as overdrive with long transmission.

*Awarded in the category "2 litre to 2.5 litre" (www.ukipme.com/engineoftheyear).
The fuel consumption and CO₂ emission figures can be found on page 54.

Superb roadholding.

quattro® permanent all-wheel drive.

Outstanding traction, improved handling dynamics and more driving safety. Or quattro for short. Hardly any other drive system around transfers the engine's power to the road so effortlessly. The quattro drivetrain has been enhanced in the Audi RS Q3 in order to transmit such enormous torque. Its electronically controlled and hydraulically operated multi-plate clutch ensures the drive torque is distributed between the front and rear axles as required and according to the driving situation. The rapid response and very short reaction times of this system are particularly impressive. In addition, the wheel-selective torque control prevents undesirable wheel slip through targeted braking actions on all wheels. The result is precisely controlled and sporty handling with increased agility while maintaining superb traction – even in challenging driving situations.





Bending the road to your will.

RS suspensions and RS brake systems.

RS brake system

Demonstrate power. With the 18-inch RS brake system fitted as standard in the Audi RS Q3. The 8-piston fixed callipers at the front axle take powerful hold of the wave brake discs, whose cast friction ring with a wave-shaped outer contour is connected to the aluminium brake disc chamber by means of steel pins. This so-called floating mounting ensures that the friction ring remains largely tension-free, thus improving stability when subjected to high temperatures. Axial perforation and cooling channels for internal ventilation increase the performance of the brake discs. The intelligent mix of materials and characteristic geometry of the friction rings help reduce weight, thus improving the balance of the unsprung masses.

RS suspensions

Show character. Self-assured, sporty. With the RS sport suspension in the Audi RS Q3. Experience outstanding directional stability and excellent agility as well as precise steering characteristics. The McPherson front axle with lower aluminium wishbones and the 4-link rear axle with separate spring/damper arrangement guarantee a sporty dynamic driving experience. With specially tuned characteristic spring and damper curves and adapted elasto-kinematics.

Optionally available: RS sport suspension plus with damper control for increased driving dynamics. For this purpose, the characteristic curves of the twin-tube shock absorbers can be electronically controlled in three stages. The damping forces vary over a large range depending on the Audi drive select mode chosen. They are regulated depending on road conditions and different driving situations, such as acceleration, braking or cornering.

The electromechanical power steering with RS-specific characteristic curve provides additional dynamism. Thanks to the low-position configuration, the steering forces are conducted just a short distance to the wheels, which provides a spontaneous steering response, precise feedback from the road and even more fun on bends. The steering also requires almost no energy when driving in a straight line, thus helping to reduce fuel consumption.

Reach your destination. The way you want.

Audi drive select.

Change character. With the standard Audi drive select in the Audi RS Q3. Individual vehicle components can be influenced at the push of a button – such as the engine characteristics, exhaust flap control and the steering torque of the electromechanical power steering – to adapt them to the prevailing driving situation. Can be set to three different modes: auto, comfort and dynamic. auto for sporty confidence. comfort for longer trips. And dynamic for more ambitious driving.

In addition, the characteristic curves of the shock absorbers on the optional RS sport suspension plus with damper control can be varied in three levels: from comfortable rolling in comfort mode to sporty, direct responsiveness in the dynamic setting.

The fuel consumption and CO₂ emission figures can be found on page 54.



A close-up, low-angle shot of the rear of a blue Audi RS Q3. The focus is on the silver and red RS Q3 badge, which is mounted on a black plastic trim piece. The car's body is a vibrant blue, and the background is dark, creating a dramatic, high-contrast effect. The lighting highlights the metallic texture of the badge and the sleek lines of the car's rear.

RS Q3

As unique as you are.
The equipment options.

Sportiness, comfort, design, functionality – whatever you demand of your Audi, it offers you a wealth of custom options. Audi equipment versions are varied and high-quality and you can tailor them entirely to your needs.

Character takes on many forms. Here are two of them.

What makes an Audi your Audi? Vehicle equipment entirely tailored to your needs. There are a wide range of options available to you for giving your vehicle the exact touch you have in mind. More sportiness? More elegance? Let yourself be inspired.

Audi RS Q3 in Misano red, pearl effect

Cast aluminium wheels in 5-arm rotor design in matt black, gloss turned finish*

Styling package black in gloss look

Exterior mirror housings in gloss black

Sport seats, front, in fine Nappa leather, black with diamond pattern in rock grey

RS multifunction sport leather steering wheel in 3-spoke design, flattened at the bottom, with shift paddles

Carbon inlays



Audi RS Q3 in Daytona grey, pearl effect

Cast aluminium wheels in 5-V-spoke design in matt titanium look, gloss turned finish*

Extended matt aluminium styling package

Sport seats, front, in fine Nappa leather, lunar silver with contrasting stitching in rock grey

RS multifunction sport leather steering wheel in 3-spoke design, flattened at the bottom, with shift paddles

Inlays in piano finish, black



The model-specific standard and optional equipment can be found in the index from page 56 onwards.

*Please note the special information relating to wheels on page 54.

Your Audi is painted not just once. But four times.

When you choose a paint colour, choose one that best reflects your own personality. Whichever colour you opt for, you can count on the outstanding quality of our painting process. Though no thicker than a human hair, the layer of paint on an Audi is actually made up of four different coats. So not only do you look radiant in your Audi, the car is also optimally protected from environmental influences and wear. For its entire lifetime.



| Solid paint finish



Cortina white

| Metallic paint finishes



Glacier white, metallic



Mythos black, metallic



Floret silver, metallic



Hainan blue, metallic

| Pearl effect paint finishes



Daytona grey, pearl effect



Misano red, pearl effect



Sepang blue, pearl effect

| Customised paint finishes



Audi exclusive customised paint finishes



The perfect connection between an Audi and the road: Audi wheels.

To make sure you have peace of mind for every metre of your drive, Audi puts its wheels through an exacting series of specialised test procedures. Hardness tests, for example, aim for maximum stability, while a copper accelerated salt spray test – CASS for short – using acetic acid guarantees the greatest possible corrosion protection. Thanks to these and many other measures, we can ensure that every Audi wheel offers maximum quality – even after scores of kilometres. No matter which of the numerous designs you choose.

| Summer wheels



Cast aluminium wheels in 5-arm structured design size 8 J x 18 with 235/50 R 18 tyres¹



Cast aluminium wheels in 5-arm rotor design in matt titanium look, gloss turned finish² size 8.5 J x 20 with 255/35 R 20 tyres¹



Cast aluminium wheels in 5-twin-spoke V design in matt titanium look, gloss turned finish² size 8.5 J x 20 with 255/35 R 20 tyres¹



Cast aluminium wheels in 5-segment-spoke design size 8.5 J x 19 with 255/40 R 19 tyres¹



Cast aluminium wheels in 5-arm rotor design in matt black, gloss turned finish² size 8.5 J x 20 with 255/35 R 20 tyres¹



Cast aluminium wheels in 10-spoke design in matt titanium look, gloss turned finish² size 8.5 J x 19 with 255/40 R 19 tyres¹



Cast aluminium wheels in 5-V-spoke design in matt titanium look, gloss turned finish² size 8.5 J x 20 with 255/35 R 20 tyres¹

The model-specific standard and optional equipment can be found in the index from page 56 onwards.

¹You will find specifications on the technical characteristics of tyres on page 59. ²Please note the special information relating to wheels on page 54.

| Winter wheels



Cast aluminium winter wheels in 5-arm structured design size 8 J x 18 with 225/50 R 18 winter tyres¹, can be fitted with snow chains, permissible top speed 210 km/h



Cast aluminium winter wheels in 5-segment-spoke design size 8.5 J x 19 with 255/40 R 19 winter tyres¹, cannot be fitted with snow chains, permissible top speed 240 km/h

Premium quality you can rely on.

You have a special place in your Audi. Exclusivity can be felt on the front and rear seats: thanks to high-quality materials and first-class workmanship. No matter which seat upholstery you choose: you're sitting in the right place.



Sport seats, front

The illustration shows sport seat, front, electrically adjustable*, in fine Nappa leather, black with contrasting stitching in rock grey.

The model-specific standard and optional equipment can be found in the index from page 56 onwards.

| Leather

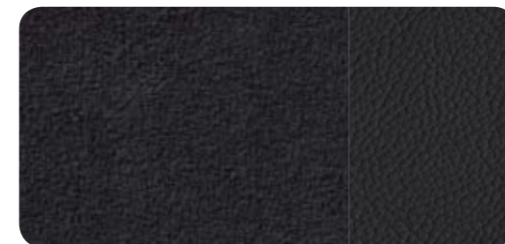

Alcantara/leather, black



Fine Nappa leather, black with contrasting stitching in rock grey



Fine Nappa leather, lunar silver with contrasting stitching in rock grey

| Leather upholstery and trim

Alcantara/leather combination

seat centre panels and door trim inserts in Alcantara, as well as seat side bolsters, head restraints and centre armrest, front (if ordered) in leather; RS Q3 embossing on the front-seat backrests

Fine Nappa leather upholstery and trim with contrasting stitching

seat upholstery and centre armrest, front (if ordered) in leather with contrasting stitching in rock grey; door trim inserts in leather to match seat colour; RS Q3 embossing on the front-seat backrests

Fine Nappa leather upholstery and trim with diamond pattern

seat upholstery and centre armrest, front (if ordered) in leather with contrasting stitching in rock grey, seat centre panel inserts with diamond pattern in rock grey; door trim inserts in leather to match seat colour; RS Q3 embossing on the front-seat backrests

Audi exclusive fine Nappa leather upholstery and trim
seat upholstery and centre armrest, front (if ordered) in leather, door trim inserts in leather to match seat colour; RS Q3 embossing on the front-seat backrests, floor mats with leather piping. Individual choice of colours for the seat upholstery, stitching and leather piping from the range of Audi exclusive colours

Audi exclusive leather upholstery and trim in fine Nappa leather with diamond pattern

seat upholstery and centre armrest, front (if ordered) in leather, seat centre panel inserts with diamond pattern; door trim inserts in leather to match seat colour; RS Q3 embossing on the front-seat backrests, floor mats with leather piping. Individual choice of colours for the seat upholstery, stitching and leather piping from the range of Audi exclusive colours



Fine Nappa leather, black with diamond pattern in rock grey

| Audi exclusive



Audi exclusive leather upholstery and trim
Individual choice of colour for leather/stitching

| Seat comfort

Driver seat, electrically adjustable

with electric adjustment of seat height, fore/aft position, seat and backrest angle; manual adjustment for front-passenger seat

Front seats, electrically adjustable

same functions as driver seat, electrically adjustable, additionally also for front-passenger seat

Seat heating, front

heats up seat and backrest centre panels and seat side bolsters; separate adjustment in several stages for the driver and front-passenger side

| Seats in the rear

Rear seat backrest, folding

can be split-folded 40:60 or fully

| Headlinings

Headlining in cloth

optionally:

in black

in lunar silver

*Optionally available in conjunction with front seats, electrically adjustable, standard version can be manually adjusted.

Experience fascination. Down to the last detail.

The exclusive Audi inlays emphasise the sporty ambience of your vehicle. At first sight. Be inspired by refined carbon, aluminium, piano finish or wood for the dashboard, centre console and door trims. High quality and precise workmanship harmoniously integrated in the interior.

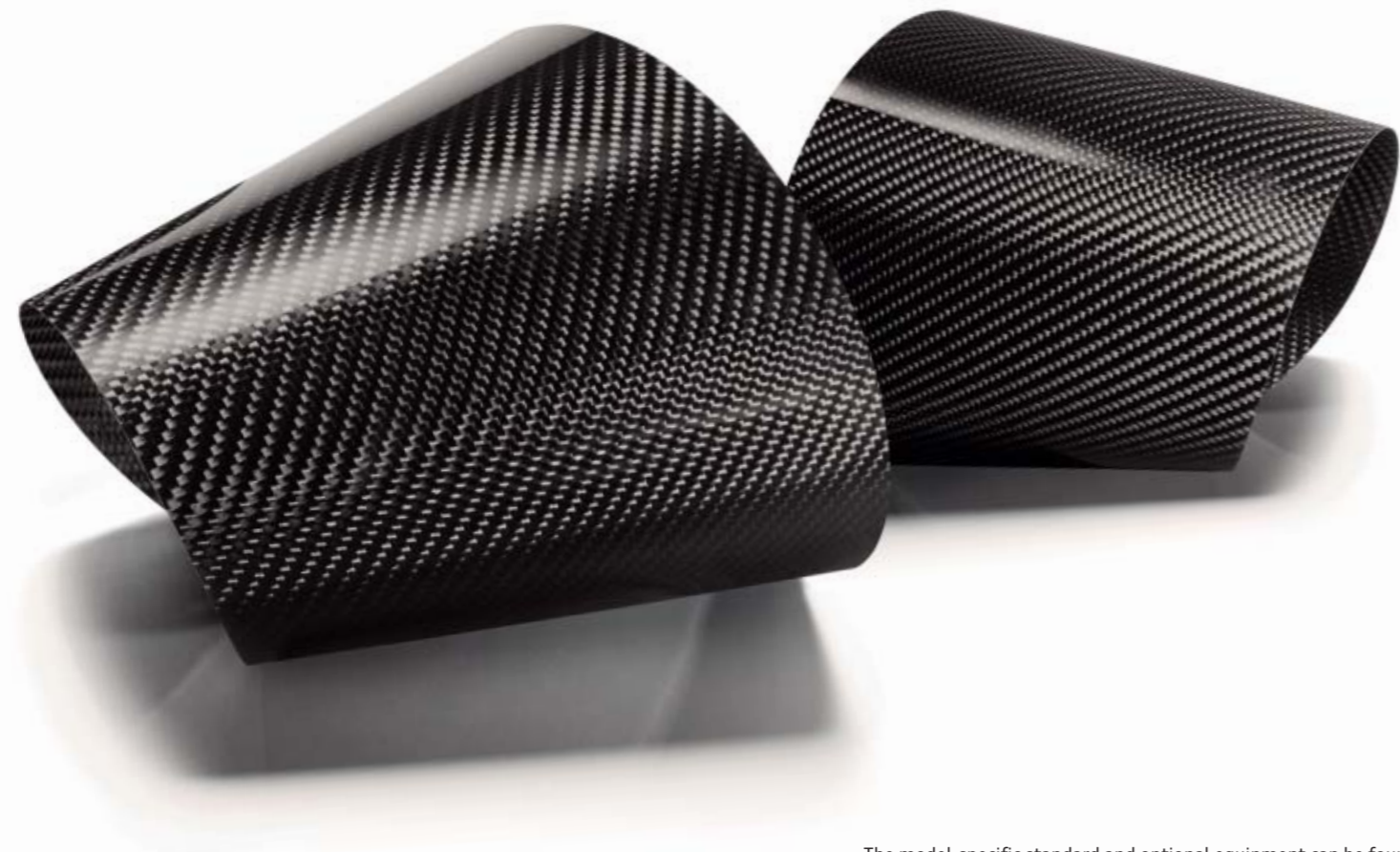

The model-specific standard and optional equipment can be found in the index from page 56 onwards.

| Inlays



Piano finish, black
additional elements on the dashboard and door trims
in aluminium look

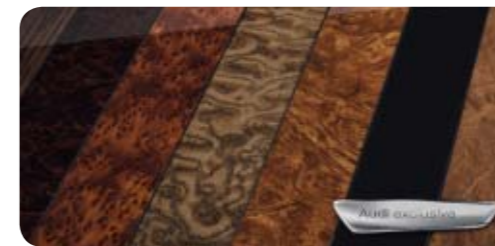

Audi exclusive wood inlays
additional elements on the dashboard and door trims
in aluminium look



Carbon
additional elements on the dashboard and door trims
in aluminium look



Inlays painted in Audi exclusive colour



Aluminium Race

Inlays

for dashboard, door trims and centre console

Audi exclusive wood inlays

available in fine grain ash, nougat, oak sepia, fine grain myrtle, nutmeg, vavona bronze, modrone gold, tamo ash, natural dark brown or painted in colour

| Headlights/interior lighting

Xenon plus

intensive road illumination, good uniformity and range thanks to headlights with durable gas discharge technology for dipped and high beam. Automatic dynamic headlight range control that prevents oncoming traffic from being dazzled. Including homogeneous LED daytime running light strip and all-weather light

LED headlights

allow precise, near daylight illumination of the road and combine dipped beam, high beam, daytime running lights, motorway light, indicator and static turning light as well as all-weather light function in LED technology; motorway light with automatically increased headlight range from a speed of approximately 110 km/h; all-weather light function to reduce the risk of the driver being dazzled when visibility is poor; striking light pattern in day and night design, including homogeneous daytime running light strip and integrated LED indicator; with low energy consumption and long service life

High-beam assist

improves the driver’s visibility and ensures a more relaxed drive thanks to the extra comfort and convenience. Depending on the traffic situation, the high beam is automatically switched on or off. Working within system limits, automatically detects the headlights of oncoming traffic, the rear lights of other road users and light sources in built-up areas

Light/rain sensor

automatic control of lights-on function, windscreen wipers and coming home/leaving home function: delayed switching-off/automatic switching-on of the main headlights, the rear lights and the number plate lights when parking/opening the vehicle; including acoustic windscreen with grey strip along the top edge

LED rear lights

brake lights, tail lights, indicators and rear number plate lights in LED technology with low power consumption; with reversing lights and 2 rear fog lights; third brake light integrated in RS roof edge spoiler

LED rear lights with dynamic indicator

in addition to the functions of the LED rear lights, a dynamic and clearly visible indicator curve is created: segments of LED arrays are triggered for a few milliseconds, creating a pulse of light that runs outwards in the direction in which the car is turning. When operated, the indicators send a distinctive signal to other road users

LED interior lighting package

anti-glare lighting for the passenger compartment in energy-saving and long-lasting LED technology, consisting of:

- interior lighting, front and rear, including reading lights
- reflected lighting for centre console and inside door handles
- vanity mirror lighting for driver and front passenger
- illuminated cup holders
- illuminated storage compartment in the centre console
- entrance and footwell lighting as well as illuminated door openers
- illuminated vent controls
- active door reflectors (light bulbs)

| Exterior design

Model name/logo

RS logo in Audi Singleframe and model name RS Q3 on the luggage compartment lid

Audi Singleframe

with radiator grille with honeycomb grid in gloss black and one-piece trim frame in matt aluminium look; in 3D-design

RS bumpers

in a sporty dynamic design; at the front with large air inlets and side flaps in gloss black as well as body-coloured air inlet ducts with quattro logo, at the rear with diffuser insert in gloss black

Trim strips

on the side windows in matt aluminium look, outer B-pillar trims outside and triangular panels on the rear doors in gloss black

Roof rails

in matt aluminium look or black matt; for transportation of items, strong and aerodynamically shaped

RS roof edge spoiler

on the luggage compartment lid, painted in body colour

Door trim strips and wheel arch trims

painted in body colour

Matt aluminium styling package

air inlet duct and front side flaps, side fins on the RS roof edge spoiler and top edge of rear diffuser insert in matt aluminium look

Extended matt aluminium styling package

equipment same as for matt aluminium styling package, but with additional quattro logo in matt aluminium look in the front air inlet duct

Styling package black in gloss look

radiator grille frame and trim strips on the side windows in gloss black, roof rails in black matt

Extended gloss black styling package

equipment same as for styling package black in gloss look; additionally side fins on the RS roof edge spoiler in gloss black

Light Design Steering wheels/controls

Interior design

Door sill trims with aluminium inlays

and RS Q3 logo

Audi exclusive floor mats with RS Q3 logo

in black, with embroidery of the front floor mats; piping and stitching in black

Comfort Infotainment Assistance systems

Steering wheels/controls

RS multifunction sport leather steering wheel in 3-spoke design, flattened at the bottom

adjustable for height and reach; with shift paddles in aluminium look, RS Q3 emblem and full-size airbag; steering wheel rim flattened at the bottom, with cover in perforated leather and contrasting stitching in rock grey; for operating the available infotainment features

RS selector lever knob in perforated leather

with RS logo and decorative ring in aluminium look; selector lever gaiter in leather with contrasting stitching in rock grey

Audi exclusive leather controls

steering wheel rim, selector lever knob and gaiter available in Audi exclusive leather. Individual choice of colour for the leather and the stitching from the range of Audi exclusive colours. Stitching on the steering wheel rim with specific Audi exclusive seam detail

Audi exclusive controls in black suede

steering wheel rim and selector lever knob in black suede. Individual choice of colour for the stitching from the range of Audi exclusive colours. Stitching on the steering wheel rim with specific Audi exclusive seam detail

Technology/safety Audi Extended Warranty

Mirrors

Exterior mirrors with integrated LED indicator

electrically adjustable and heated, convex, flat or aspherical mirror glass; including heated windscreen washer jets

also optionally:

electrically folding

including automatic kerb-side function for the exterior mirror on the passenger side

electrically folding, automatically dimming on the driver side

including automatic kerb-side function for the exterior mirror on the passenger side

The automatic kerb-side function tilts the exterior mirror on the passenger side downwards when reverse gear is selected, giving the driver a better view of the kerb.

Exterior mirror housings

optionally:

in matt aluminium look

painted in body colour

in gloss black

| Roof system

Panoramic glass sunroof

in 2 sections, electrical activation to raise and open the front glass section; with tinted glass insert and electrically operated sun blind for the front and rear passengers, as well as convenience closing/opening from the outside via the vehicle key; ensures an interior that is flooded with light, improves the interior climate by means of efficient ventilation; including integrated wind deflector

| Glazing

Heat-insulating glass

green tinted; windscreen made of laminated glass; heated rear window with timer switch

Acoustic windscreen

heat-insulating glass with improved acoustic windscreen insulation, with grey strip

Dark-tinted windows (privacy glazing)

dark-tinted rear window and rear door windows and side windows

| Climate control

Manual air conditioning

- cools or heats up the vehicle passenger compartment
- separate defroster button for faster defrosting of front and side windows
- manually regulated air distribution
- manual recirculation mode
- 4-speed blower and combined pollutant and pollen filter

- 4 air vents in the dashboard
- footwell vents, front and rear

Deluxe automatic air conditioning

- electronically controls the air temperature, flow rate and distribution
- separate temperature control for driver and front-passenger seat
- separate defroster button for faster defrosting of front and side windows
- automatic recirculation mode by means of air quality sensor
- sunlight-dependent control
- combined filter
- with light/rain and humidity sensor
- air vents in the centre console, rear
- ventilated glove compartment
- key-coded settings

| Closing systems

Convenience key

access authorisation system, where the key only needs to be carried with you; the engine is started and switched off via the engine start-stop button, the vehicle is unlocked and locked from outside via sensors on the driver and front-passenger door handles. The luggage compartment lid can also be opened separately when the vehicle is locked.

Luggage compartment lid, electrically opening and closing

opens via a button on the vehicle key or in the driver door or by means of the soft-touch button in the luggage compartment lid handle recess; closes via a button on the inside of the luggage compartment lid, the button in the driver door or the optional convenience key (pressed longer). In conjunction with the convenience key, it is possible to close the luggage compartment lid and simultaneously lock the car via an additional button on the inside of the luggage compartment lid. Including power-assisted closing and programmable luggage compartment lid opening angle

Anti-theft alarm

monitors doors, bonnet and luggage compartment lid; includes interior monitoring (can be deactivated), tow-away protection via tilt angle sensor and signal horn independent of vehicle electrical system; with safety guarantee: prevents doors being opened from the inside as soon as the vehicle has been locked using the vehicle key

Preparation for tracking system

preparation for connecting a tracking system (available from Audi Genuine Accessories) that enables a stolen vehicle to be located and tracked

| Storage/transport

Storage compartments

storage compartment in the door trims, including bottle holder (1.5 l) at front, storage compartment and two cup holders in the front centre console, glove compartment on the front-passenger side

Storage package

- storage net on the back of the front-seat backrests
- storage compartment under the front seats
- lockable glove compartment
- multi-fastening point in the front-passenger footwell

Luggage compartment package

- flexible transport of objects and convenient for travel; comprising:
 - luggage compartment net for attaching to lashing points on the luggage compartment floor
 - net at the side
 - 12V socket
 - additional luggage compartment light on the left

Through-loading facility

provides extended loading possibility for the practical transportation of long objects; including centre armrest, rear with cup holders and storage compartment

Reversible mat

for covering the luggage compartment, can also be used with the rear seat backrest folded down; velour on one side and rubber coated on the other; with fold-out cover for loading sill and bumper

Light Design Steering wheels/controls

Reversible luggage compartment floor

one side in high-quality dilour, the other side waterproof and hard-wearing, additional storage compartments under the reversible luggage compartment floor

Trailer towing hitch

mechanically swivelling, bar and ball head made from forged steel; operated via pull-button in the luggage compartment, with control light in the luggage compartment and display in instrument cluster to monitor secure attachment of trailer towing hitch. The 13-pin socket can be swivelled out of sight behind the bumper skirt and permits the permanent operation of electrical devices in the trailer or caravan during driving. Trailer stabilisation via the Electronic Stabilisation Control (ESC)

Provision for trailer towing hitch

includes preparation for the control units and a reinforced engine cooling

Comfort Infotainment Assistance systems

| MMI®/navigation

RS instrument cluster

with grey dials, red needles, white scales, RS logo in the rev counter and dynamic ready-check feature

Driver information system with colour display

high resolution 3.5-inch colour display directly in the driver's field of vision; displays information from the MMI system, infotainment systems and driver assistance systems, if available; display of onboard computer with short- and long-term memory, digital speedometer, gear change recommendation (in the manual mode of S tronic), external temperature, RS menu with charging pressure and oil temperature display, as well as lap timer; operation via the RS multifunction sport leather steering wheel; includes attention assist: attention assist provides a warning in the driver information system and via acoustic signal if the system determines that the driver's attention is lapsing.

Navigation package

includes:

- connectivity package
- navigation function and data on SD card¹
- maps shown on 6.5-inch colour display

Operation via MMI radio, RS multifunction sport leather steering wheel or voice control system

Technology/safety

Audi Extended Warranty

MMI® navigation plus

- navigation system¹
- high-resolution 7-inch colour display
- map display with topographical map colouring, display of lots of sightseeing information and city models in 3D, choice of three alternative routes
- rotary/push-button control with integrated joystick function to search on the map
- split-screen mode for route information (manoeuvring points, points of interest on motorways, TMCpro on route), detailed junction map and lane recommendation
- dynamic route guidance with TMCpro (in conjunction with Audi connect: traffic information online²)
- voice control system with whole-word entry of address in one sentence
- additional arrow display in the driver information system
- radio with 3-way tuner and phase diversity
- hard drive can also be used to store music (20 GB)
- DVD player (MP3, WMA, AAC and MPEG-4 compatible), can be used for music CDs and video DVDs
- 2 SDHC card readers (up to 32 GB)
- Audi music interface
- Bluetooth interface with Bluetooth audio streaming
- Audi sound system
- use of services supported by Audi connect³

^[1] The model-specific standard and optional equipment can be found in the index from page 56 onwards.

^[1] Navigation data available for supported countries on integrated memory or SD card. For more information, please contact your Audi partner. ^[2]The Audi connect service traffic information online is available for many countries.

^[3] Requires the optional Audi connect including car phone.

| Entertainment

MMI® radio

- integrated MMI control concept with offset 6.5-inch colour display and car menu
- CD drive and SDHC memory card reader (up to 32 GB), both MP3, WMA and AAC-capable and AUX-IN connection
- 50-station memory with dynamic station list, FM (VHF) and AM (MW) reception; phase diversity and speed-dependent volume control, TP memo function whilst driving
- Audi sound system

Digital Audio Broadcasting

In addition to the range of analogue stations, reception of digitally broadcast radio stations¹ according to DAB standard, including DAB+ and DMB audio; display of information accompanying the programme (e.g. artist and title, depending on provision by the respective radio station) as well as additional information in the form of a slide show (e.g. cover and weather)

Digital TV reception

reception of digitally-broadcast, uncoded television stations¹ (in DVB-T standard with MPEG-2 or MPEG-4 standard) as well as DVB-T audio stations; display of information accompanying the programmes such as teletext and Electronic Programme Guide (EPG); automatic station search; external AV-IN connection via adapter cable; no picture possible when the vehicle is moving

Audi music interface

portable media players² such as Apple iPod/iPhone (music functionality) and USB storage media and MP3 players may be connected to the vehicle. Located in the centre console; operation via the MMI or the RS multifunction sport leather steering wheel; part of the connectivity package, navigation package and MMI navigation plus. Specific Audi Genuine Accessories adapter cables are required to connect portable media players or USB storage media. Adapter cables matching respective devices can also be selected. Additional adapter cables are available from Audi Genuine Accessories. In conjunction with the Audi music interface, the AUX-IN connection is omitted.

Audi music interface online²

extends the Audi music interface by the following functions: internet radio stations and podcasts can be recorded via your Wi-Fi home network and played in the vehicle. Internet radio stations can be listened to live in the vehicle. The Audi music interface online makes it possible to create a Wi-Fi hotspot in the vehicle (when a USB broadband modem is used).

Audi sound system

impressive sound thanks to 6-channel amplifier with a total output of 180 watts as well as 10 loudspeakers including centre speaker and subwoofer

Bose Surround Sound

impressive reproduction of 5.1 surround sound through 10-channel amplifier with a total output of 465 watts and 14 loudspeakers including centre speaker and subwoofer; AudioPilot® for noise-dependent volume adjustment, powerful and accurate bass reproduction, lifelike sound with natural tone and a feeling of space for an impressive sound experience. A particular design highlight is the floating effect of the front loudspeakers created by indirect lighting in LED technology.

| Communication

Audi connect including car phone

use of Audi connect and more convenient phoning thanks to integrated car phone; connection of the vehicle to the internet via integrated data module. Import of phone book entries and call list management possible.

The following services supported by Audi connect are currently available in your model:

Mobility & navigation

- Point-of-interest (POI) search with voice control
- Traffic information online³
- Country information
- Fuel prices
- Parking information
- Navigation with Google Earth™⁴ and Google Street View™⁴
- Destination entry via myAudi or Google Maps™⁴

Communication

- Wi-Fi hotspot

Infotainment

- Weather
- Audi music stream
- News online (individual)
- Travel information

Use of the services supported by Audi connect is possible only with the optional MMI navigation plus equipment and with Audi connect including car phone. You also require a SIM card with data option – with car phone, a SIM card with phone and data option or a Bluetooth-capable smartphone⁵ with remote SIM Access Profile (rSAP). There is a reader for your SIM card in the surround of the MMI navigation plus. The services are available only with an existing or separate mobile phone contract and only within the range of the respective mobile phone network. Additional costs may be incurred when receiving data packets from the internet, depending on the terms of your mobile phone contract, particularly when used abroad. Because of the high data volumes involved, a data flat rate is strongly recommended.

The availability of the services supported by Audi connect varies from country to country. The Audi connect services are provided for at least 1 year from vehicle delivery. After 24 months have expired, Audi connect services will be extended free of charge once for 12 months. If you do not require this free extension, please write to:

AUDI AG

Audi International Customer Care Services

D-85045 Ingolstadt

Email: kundenbetreuung@audi.de

Tel.: + 49 (0) 800-2834 7378423

The city events service and further services are available to the customer for 12 months. Ask your Audi partner about a subsequent extension of the Audi connect services.

Please visit www.audi.com/connect or contact your Audi partner for more detailed information about Audi connect; contact your mobile services provider for information about contract conditions.

Audi MMI® connect app

The Audi MMI connect app available for some smartphones⁵ supports the following Audi connect services:

- Audi music stream
- Point-of-interest (POI) search with voice control
- Destination entry via myAudi or Google Maps™⁴
- Traffic information online³

Bluetooth interface

allows hands-free calls to be made in the vehicle using the microphone and – depending on mobile phone compatibility⁵ – Bluetooth audio streaming. Bluetooth-capable mobile phones can be connected to the vehicle via the interface.

Audi phone box⁵

allows phone calls with improved reception quality by placing mobile phone into the universal phone holder near the centre armrest, front; hands-free facility and voice control (telephone); low SAR radiation in the interior of the vehicle thanks to connection to vehicle aerial; operated via the MMI or the RS multifunction sport leather steering wheel; can be charged via USB port

Connectivity package

combines the following features:

- Audi music interface
- Bluetooth interface with Bluetooth audio streaming
- preparation for navigation system (navigation function and map data available as retrofit solution from Audi Genuine Accessories)
- additional SDHC card reader (for up to 32 GB)

In conjunction with the Audi music interface, the AUX-IN connection is omitted.

Light Design Steering wheels/controls

Comfort

Infotainment

Assistance systems

Technology/safety

Audi Extended Warranty

| Assistance systems

Hold assist⁶

holds the vehicle over an indefinite period of time on the uphill or downhill gradients usual in traffic. The system is activated via push button and allows the driver to pull away smoothly.

Hill descent control⁶

maintains selected speed on downhill drives; activated by pushing a button

Parking system plus⁶

acoustic and visual parking system, front and rear assists with parking and manoeuvring. Shown on the MMI display; measurement by ultrasonic sensors concealed in the bumpers; activated when reverse gear is selected or via a button on the centre console

Parking system plus with reversing camera⁶

acoustic and visual parking system, front and rear; image of area behind the vehicle shown on the MMI display, with dynamic display modes showing the path calculated based on steering angle; auxiliary lines and guidelines as well as indication of the point at which to apply opposite lock when parallel parking; reversing camera integrated discreetly in the handle strip of the luggage compartment lid; activated when reverse gear is selected or via a button on the centre console

Cruise control⁶

At speeds of 30 km/h and above, the system keeps the set speed constant if engine power and engine braking effect permit it; operated via separate steering column stalk, set speed displayed in driver information system

Audi side assist⁶

warns by means of an LED display on the relevant exterior mirror of any situations assessed as critical for lane-changing. Radar sensors detect vehicles approaching from behind and measure the distance and the difference in speed. The lane change assistant provides support at speeds above around 30 km/h. In conjunction with the optional Audi active lane assist, the display in the corresponding mirror may flash even if you did not indicate: if you approach a detected boundary line and are on the verge of drifting out of your lane, Audi side assist uses this method to warn you of detected vehicles that are classified as critical. Activated via a button in the mirror quadrant

Audi active lane assist⁶

helps you to keep in lane by means of gentle steering intervention. The lane compliance assistant is triggered when the driver starts to cross detected lane markings without activating an indicator. The system provides assistance from speeds of around 60 km/h. Steering wheel vibration can be adjusted if the driver wishes. In conjunction with MMI navigation plus, the system includes the camera-based recognition of traffic signs. Including high-beam assist; activated via a button on the steering column stalk of the indicator

Camera-based recognition of traffic signs^{6,7}

traffic sign recognition for overtaking bans and speed limits, including temporary speed limit displays (e.g. above motorways); situation-dependent evaluation in wet conditions and in fog, speed limits depending on the time of day and when using a trailer⁸. The traffic sign recognition feature can detect standardised speed limits within the viewing range of the camera within system limits. Supported by Audi connect navigation data, the detected limits are evaluated and automatically shown in the driver information system. Traffic sign recognition output can be configured via the RS multifunction sport leather steering wheel. Up to 3 traffic signs can be exclusively shown in the display of the instrument cluster or the relevant speed limit at the current time as additional display for another system (e.g. digital speed limit display). The system has purely informative character, there is no manipulation and no warning if the displayed speed is exceeded.

^[1] Reception depends on digital network availability.

^[2] Please contact your Audi partner or visit www.audi.com/mp3 for information on compatible media players.

^[3] The Audi connect service traffic information online is available for many countries. For more information, please contact your Audi partner.

^[4] Google and the Google logo are registered trademarks of Google Inc.

^[5] Please contact your Audi partner or visit www.audi.com/bluetooth for information on compatible mobile phones.

^[6] Please note: The systems work only within system limits and support the driver. However, the driver remains responsible for driving the vehicle and is required to be attentive at all times.

^[7] Only available for Western Europe.

^[8] Only applies for factory-fitted trailer towing hitches.

| Driving dynamics/brakes

Audi drive select

sets the vehicle characteristics in the available modes comfort, auto and dynamic by adapting the power steering assistance, engine characteristics and exhaust flap control. The system also influences the optional RS sport suspension plus with damper control.

RS sport suspension

- with dynamically tuned spring/damper combination
- McPherson front axle with lower aluminium wishbones
- 4-link rear axle with separate spring/damper arrangement

RS sport suspension plus with damper control

- adjustable in 3 stages
- McPherson front axle with lower aluminium wishbones
- 4-link rear axle with separate spring/damper arrangement
- damping forces can be selected in 3 stages via Audi drive select: comfort, auto, dynamic.

quattro®

permanent all-wheel drive with wheel-selective torque distribution, electronically controlled multi-plate clutch on the rear axle, as well as Electronic Differential Lock (EDL); distribution of drive forces depending on the driving situation to each individual wheel for precisely controlled, sporty handling; quattro emblem on the passenger side of the dashboard

S tronic®

7-speed dual-clutch transmission with electrohydraulic actuation allows faster gear changing with virtually no perceptive break in propulsive power. Automatic transmission with programmes D (Drive) and S (Sport); manual control via shift paddles on the RS multifunction sport leather steering wheel or by nudging the selector lever. Includes hill hold assist

Electromechanical power steering

combines precision and comfort with exceptional energy-saving technology. The electromechanical steering system with speed-sensitive power steering assistance ensures stability at high speeds whilst also being light and precise when parking and manoeuvring. With active countersteering which gives the driver a steering recommendation for the better stabilisation of the vehicle

RS brake system

18-inch high-performance brake system, diagonally-split, Antilock Brake System (ABS) with Electronic Brake Force Distribution (EBD), Electronic Stabilisation Control (ESC), hydraulic brake assist, adapted brake booster function; wave brake discs at front in composite design, ventilated and perforated, rear brake discs ventilated; brake callipers painted in gloss black, with RS logo at the front

Brake callipers, painted in gloss red

for RS brake system, with RS logo at the front

| Technology/safety

Electronic Stabilisation Control (ESC)

with sport mode, can be deactivated in 2 stages; provides better stability by targeted braking of individual wheels and intervention in the engine management system; networks the ABS, EBD, ASR and EDL with its own sensors and compares driving data with reference data

RS exhaust system

with chrome-plated oval tailpipe trim on the left

Recuperation

economises on fuel through brake energy recovery; kinetic energy is converted into usable electrical energy by increasing the generator voltage when the vehicle is coasting or braking and relieving the generator during subsequent acceleration

Start-stop system

helps to reduce fuel consumption and CO₂ emission by automatically switching off the engine when stationary, e.g. at traffic lights. The start process is initiated as soon as the foot brake is released. May be deactivated using a button at any time

Side airbags, rear

to supplement the side airbags, front and head airbag system

ISOFIX child seat mounting and top tether for the outer rear seats

standard mounting for practical attachment of ISOFIX child-seat mounting, including additional fastening point (top tether).

Recommended child seats can be obtained from your Audi partner.

ISOFIX child seat mounting for the front-passenger seat

with front-passenger airbag deactivation switch, includes separate electric child-proof lock for the rear doors

| Audi Extended Warranty

Audi Extended Warranty

The Audi Extended Warranty provides extended risk cover and cost control beyond the first 2 years of the manufacturer's warranty for a variety of claims. It can be ordered directly and only on purchase of a new car. Choose from 9 combinations of service life and mileage. For more information, please contact your Audi partner.

Model	RS Q3
Engine type	5-cylinder inline petrol engine with direct fuel injection and turbocharging with intercooling
Displacement in cc (valves per cylinder)	2,480 (4)
Max. output ¹ in kW at rpm	250/5,300–6,700
Max. torque in Nm at rpm	450/1,600–5,300
Power transmission	
Drive type	quattro® permanent all-wheel drive
Transmission type	7-speed S tronic
Weights/capacities	
Unladen weight ² in kg	1,730
Gross vehicle weight in kg	2,215
Permissible roof load limit/ nose weight in kg	75/80
Trailer load limit ³ in kg	
unbraked	750
12 % gradient	1,900
8 % gradient	1,900
Fuel tank capacity, approx. in l	64
Performance/consumption⁴	
Top speed in km/h	250 ⁵
Acceleration 0–100 km/h in s	4.8
Fuel grade	Sulphur-free SuperPlus RON 98 ⁶
Fuel consumption ⁷ in l/100 km	
urban	11.8–11.6
extra-urban	6.8–6.6
combined	8.6–8.4
CO ₂ emission ⁷ in g/km	
urban	277–272
extra-urban	161–156
combined	203–198
Emission standard	EU6

Explanatory notes

¹ The figure given was calculated using the specified measuring procedure (current version of UN-R 85).

² Unladen vehicle weight includes driver (75 kg) and fuel tank 90 % full, calculated in accordance with the current version of Reg. (EU) 1230/2012. Optional equipment may increase the car's unladen weight and drag coefficient, whereupon the possible payload limit and the top speed will be reduced accordingly.

³ The engine's power output always decreases with increasing altitude. At 1,000 m above sea level, and for every additional 1,000 m, deduct 10 % from the weight of the outfit (trailer load limit + gross weight of the towing vehicle). Figure for trailer load limit applies to factory-fitted trailer towing hitch. If using the vehicle with a trailer towing hitch for commercial purposes, a digital tachograph may be required under certain conditions.

⁴ Fuel consumption and CO₂ emission figures given in ranges depend on the tyre/wheel sets used.

⁵ Regulated.

⁶ We recommend using sulphur-free SuperPlus unleaded RON 98 fuel complying with DIN EN 228. If this is not available, use sulphur-free super unleaded RON 95 fuel in accordance with DIN EN 228; power output will be slightly reduced. Unleaded RON 95 fuel with a maximum ethanol content of 10 % (E10) can generally be used. Fuel consumption details refer to operation with RON 95 fuel complying with 692/2008/EC.

⁷ The figures given were calculated using the specified measuring procedures. The figures do not refer to one individual vehicle and do not form part of any offer, but rather should be used purely for purposes of comparison between the different vehicle models.

Important note

Special information about the wheels: Wheels with gloss turned finish as well as polished or partly polished aluminium wheels must not be used in wintry road conditions. For manufacturing reasons, the rim surface does not have sufficient corrosion protection for such use and can be damaged permanently by road salt or similar.

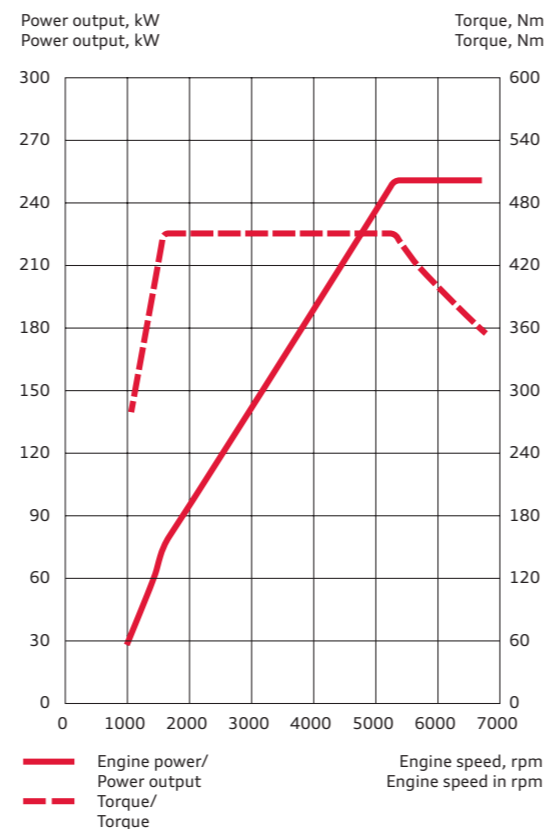
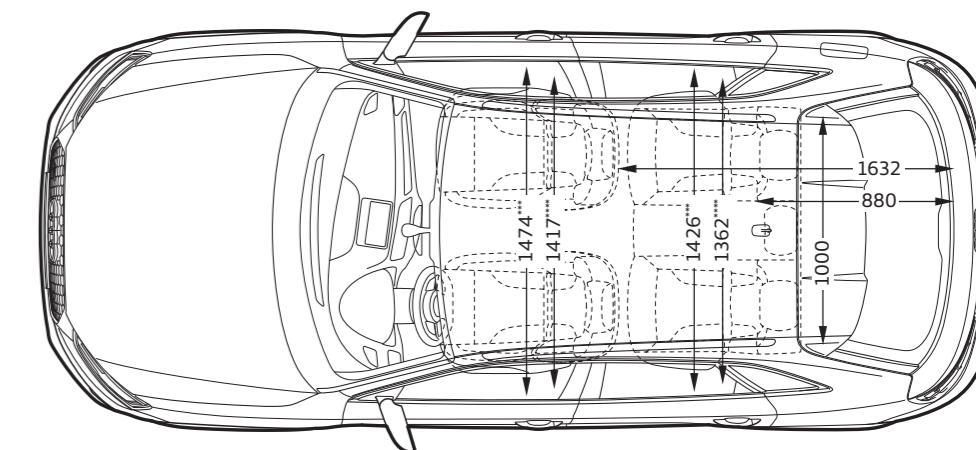
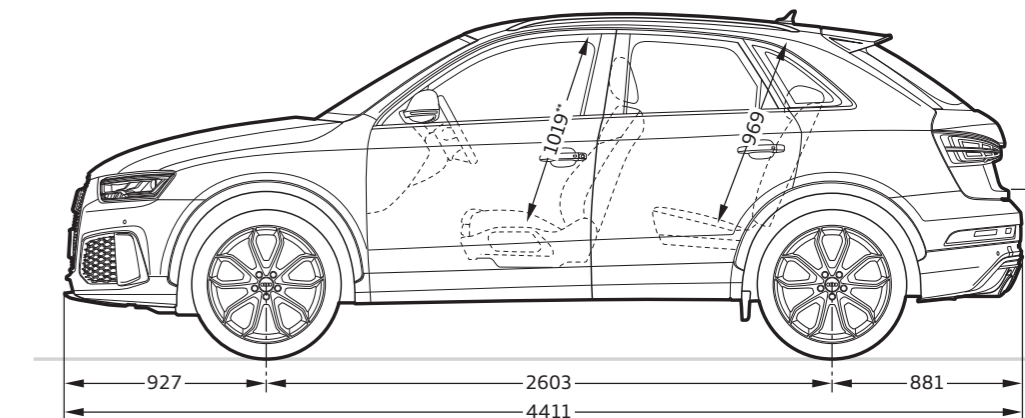
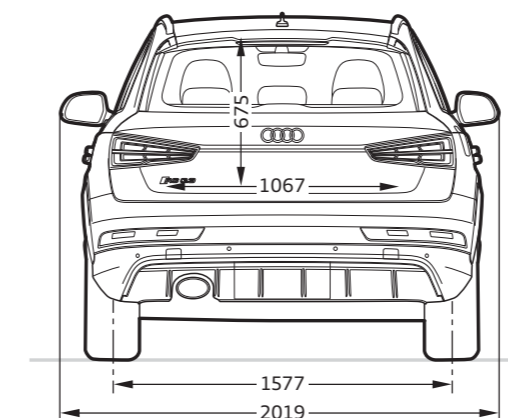
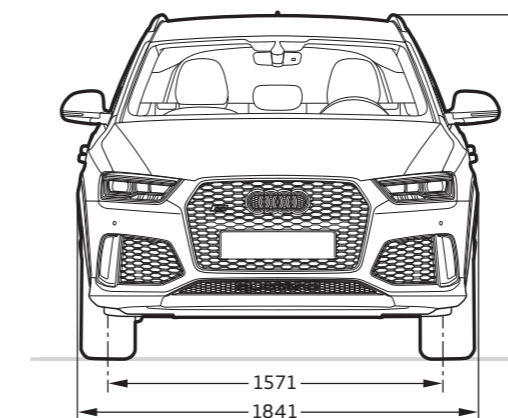









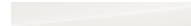

**Audi RS Q3****Dimensions in millimetres.**

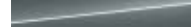







Dimensions were measured with unladen vehicle weight.



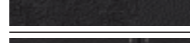
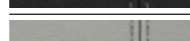

Luggage compartment volume 356/1,261 l (second value with the rear seat backrest folded down and vehicle loaded up to roof height). Turning circle approx. 11.8 m.

*With roof aerial the height of the vehicle is increased by 18 mm. **Maximum headroom.

Elbow room width. *Shoulder room width.

Solid paint finish	38
 Cortina white	<input type="checkbox"/>
Metallic paint finishes	39
 Glacier white, metallic	<input checked="" type="checkbox"/>
 Floret silver, metallic	<input checked="" type="checkbox"/>
 Hainan blue, metallic	<input checked="" type="checkbox"/>
 Mythos black, metallic	<input checked="" type="checkbox"/>
Pearl effect paint finishes	39
 Daytona grey, pearl effect	<input checked="" type="checkbox"/>
 Misano red, pearl effect	<input checked="" type="checkbox"/>
 Sepang blue, pearl effect	<input checked="" type="checkbox"/>
Customised paint finishes	39
 Audi exclusive customised paint finishes	<input checked="" type="checkbox"/>
Wheels/tyres	41
 18" cast aluminium wheels in 5-arm structured design	<input type="checkbox"/>
 19" cast aluminium wheels in 5-segment-spoke design	<input checked="" type="checkbox"/>
 19" cast aluminium wheels in 10-spoke design in matt titanium look, gloss turned finish*	<input checked="" type="checkbox"/>
 20" cast aluminium wheels in 5-arm rotor design in matt titanium look, gloss turned finish*	<input checked="" type="checkbox"/>
 20" cast aluminium wheels in 5-arm rotor design in matt black, gloss turned finish*	<input checked="" type="checkbox"/>

 20" cast aluminium wheels in 5-V-spoke design in matt titanium look, gloss turned finish*	<input checked="" type="checkbox"/>
 20" cast aluminium wheels in 5-twin-spoke V design in matt titanium look, gloss turned finish*	<input checked="" type="checkbox"/>
 18" cast aluminium winter wheels in 5-arm structured design	<input checked="" type="checkbox"/>
 19" cast aluminium winter wheels in 5-segment-spoke design	<input checked="" type="checkbox"/>
Anti-theft wheel bolts	<input checked="" type="checkbox"/>
Tyre repair kit	<input type="checkbox"/>
Tyre pressure loss indicator	<input checked="" type="checkbox"/>
Vehicle tool kit	<input type="checkbox"/>
Vehicle jack	<input checked="" type="checkbox"/>
Seats	42
Sport seats, front	<input type="checkbox"/>
Seat upholstery for sport seats, front	42
 Alcantara/leather, black	<input type="checkbox"/>
 Fine Nappa leather, black with contrasting stitching in rock grey	<input checked="" type="checkbox"/>
 Fine Nappa leather, lunar silver with contrasting stitching in rock grey	<input checked="" type="checkbox"/>
 Fine Nappa leather, black with diamond pattern in rock grey	<input checked="" type="checkbox"/>
 Audi exclusive leather upholstery and trim	<input checked="" type="checkbox"/>
Leather upholstery and trim	43
Alcantara/leather combination	<input type="checkbox"/>
Fine Nappa leather upholstery and trim with contrasting stitching	<input checked="" type="checkbox"/>
Fine Nappa leather upholstery and trim with diamond pattern	<input checked="" type="checkbox"/>
Audi exclusive fine Nappa leather upholstery and trim	<input checked="" type="checkbox"/>
Audi exclusive leather upholstery and trim in fine Nappa leather with diamond pattern	<input checked="" type="checkbox"/>

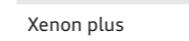
Seat comfort	43
Driver seat, electrically adjustable	<input checked="" type="checkbox"/>
Front seats, electrically adjustable	<input checked="" type="checkbox"/>
4-way lumbar support for the front seats	<input type="checkbox"/>
Seat heating, front	<input checked="" type="checkbox"/>
Centre armrest, front	<input checked="" type="checkbox"/>
Seats in the rear	43
Rear seat backrest, folding	<input type="checkbox"/>
Headlinings	43
Headlining in black cloth	<input type="checkbox"/>
Headlining in lunar silver cloth	<input checked="" type="checkbox"/>
Inlays	44
 Piano finish, black	<input type="checkbox"/>
 Carbon	<input checked="" type="checkbox"/>
 Aluminium Race	<input checked="" type="checkbox"/>
 Audi exclusive wood inlays	<input checked="" type="checkbox"/>
 Inlays painted in Audi exclusive colour	<input checked="" type="checkbox"/>
Headlights/interior lighting	46
Xenon plus	<input type="checkbox"/>
LED headlights	<input checked="" type="checkbox"/>
High-beam assist	<input checked="" type="checkbox"/>
Light/rain sensor	<input checked="" type="checkbox"/>
LED rear lights	<input type="checkbox"/>
LED rear lights with dynamic indicator	<input checked="" type="checkbox"/>
Interior lighting	<input type="checkbox"/>
LED interior lighting package	<input checked="" type="checkbox"/>

Exterior design	46
Model name/logo	<input type="checkbox"/>
Audi Singleframe	<input type="checkbox"/>
RS bumpers	<input type="checkbox"/>
Trim strips	<input type="checkbox"/>
Roof rails in matt aluminium look	<input type="checkbox"/>
Roof rails in black matt	<input checked="" type="checkbox"/>
RS roof edge spoiler	<input type="checkbox"/>
Door trim strips and wheel arch trims	<input type="checkbox"/>
Matt aluminium styling package	<input checked="" type="checkbox"/>
Extended matt aluminium styling package	<input checked="" type="checkbox"/>
Styling package black in gloss look	<input checked="" type="checkbox"/>
Extended gloss black styling package	<input checked="" type="checkbox"/>
Interior design	47
Door sill trims with aluminium inlays	<input type="checkbox"/>
Floor mats, front and rear	<input type="checkbox"/>
Audi exclusive floor mats with RS Q3 logo	<input checked="" type="checkbox"/>
Pedals and footrest in stainless steel	<input type="checkbox"/>
Steering wheels/controls	47
RS multifunction sport leather steering wheel in 3-spoke design, flattened at the bottom	<input type="checkbox"/>
RS selector lever knob in perforated leather	<input type="checkbox"/>
Audi exclusive leather controls	<input checked="" type="checkbox"/>
Audi exclusive controls in black suede	<input checked="" type="checkbox"/>
Mirrors	47
Exterior mirrors with integrated LED indicator	<input type="checkbox"/>
Exterior mirrors, additionally electrically folding	<input checked="" type="checkbox"/>
Exterior mirrors, additionally electrically folding, automatically dimming on the driver side	<input checked="" type="checkbox"/>
Exterior mirror housings in matt aluminium look	<input type="checkbox"/>
Exterior mirror housings painted in body colour	<input checked="" type="checkbox"/>
Exterior mirror housings in gloss black	<input checked="" type="checkbox"/>

Standard equipment Optional equipment

Country-specific variations possible. Please find out from your local Audi partner which equipment is standard and what optional equipment is available in your country.

More detailed descriptions of a selection of items from the equipment range can be found from page 34 onwards.

*Please note the special information relating to wheels on page 54.

Mirrors (continued)	47
Interior mirror, manually dimming	<input type="checkbox"/>
Interior mirror, automatically dimming	<input checked="" type="checkbox"/>
Vanity mirrors	<input type="checkbox"/>
Roof system	48
Panoramic glass sunroof	<input checked="" type="checkbox"/>
Glazing	48
Heat-insulating glass, tinted green	<input type="checkbox"/>
Acoustic windscreen	<input checked="" type="checkbox"/>
Dark-tinted windows (privacy glazing)	<input checked="" type="checkbox"/>
Sun visors, hinged and swivel-mounted	<input type="checkbox"/>
Climate control	48
Manual air conditioning	<input type="checkbox"/>
Deluxe automatic air conditioning	<input checked="" type="checkbox"/>
Closing systems	48
Remote control key with RS emblem	<input type="checkbox"/>
Engine start-stop button with red ring	<input checked="" type="checkbox"/>
Convenience key	<input checked="" type="checkbox"/>
Electronic immobiliser	<input type="checkbox"/>
Luggage compartment lid, electrically opening and closing	<input checked="" type="checkbox"/>
Anti-theft alarm	<input checked="" type="checkbox"/>
Preparation for tracking system	<input checked="" type="checkbox"/>
Storage/transport	49
Storage compartments	<input type="checkbox"/>
Storage package	<input checked="" type="checkbox"/>
Luggage compartment package	<input checked="" type="checkbox"/>
Luggage compartment cover, extendable	<input type="checkbox"/>
Through-loading facility	<input checked="" type="checkbox"/>

Reversible mat	<input checked="" type="checkbox"/>
Reversible luggage compartment floor	<input type="checkbox"/>
Lashing points, set of 4	<input type="checkbox"/>
Loading sill protector in stainless steel	<input type="checkbox"/>
Cigarette lighter and ashtray	<input checked="" type="checkbox"/>
12V socket	<input type="checkbox"/>
Trailer towing hitch	<input checked="" type="checkbox"/>
Provision for trailer towing hitch	<input checked="" type="checkbox"/>
MMI®/navigation	49
RS instrument cluster	<input type="checkbox"/>
Driver information system with colour display	<input type="checkbox"/>
Attention assist	<input type="checkbox"/>
Navigation package	<input checked="" type="checkbox"/>
MMI® navigation plus	<input checked="" type="checkbox"/>
Entertainment	50
MMI® radio	<input type="checkbox"/>
Digital Audio Broadcasting	<input checked="" type="checkbox"/>
Digital TV reception	<input checked="" type="checkbox"/>
Audi music interface	<input checked="" type="checkbox"/>
Audi music interface online	<input checked="" type="checkbox"/>
Audi sound system	<input type="checkbox"/>
Bose Surround Sound	<input checked="" type="checkbox"/>
Communication	50
Audi connect including car phone	<input checked="" type="checkbox"/>
Bluetooth interface	<input checked="" type="checkbox"/>
Audi phone box	<input checked="" type="checkbox"/>
Connectivity package	<input checked="" type="checkbox"/>

Assistance systems	51
Hold assist	<input checked="" type="checkbox"/>
Hill hold assist	<input type="checkbox"/>
Hill descent control	<input checked="" type="checkbox"/>
Parking system plus	<input type="checkbox"/>
Parking system plus with reversing camera	<input checked="" type="checkbox"/>
Cruise control	<input checked="" type="checkbox"/>
Audi side assist	<input checked="" type="checkbox"/>
Audi active lane assist	<input checked="" type="checkbox"/>
Camera-based recognition of traffic signs	<input checked="" type="checkbox"/>
Driving dynamics/brakes	52
Audi drive select	<input type="checkbox"/>
RS sport suspension	<input type="checkbox"/>
RS sport suspension plus with damper control	<input checked="" type="checkbox"/>
quattro®	<input type="checkbox"/>
S tronic®	<input type="checkbox"/>
Electromechanical power steering	<input type="checkbox"/>
RS brake system	<input type="checkbox"/>
Brake callipers, painted in gloss black	<input type="checkbox"/>
Brake callipers, painted in gloss red	<input checked="" type="checkbox"/>
Electromechanical parking brake	<input type="checkbox"/>
Technology/safety	52
Antilock Brake System (ABS)	<input type="checkbox"/>
Anti-Slip Regulation (ASR)	<input type="checkbox"/>
Electronic Differential Lock (EDL)	<input type="checkbox"/>
Electronic Stabilisation Control (ESC)	<input type="checkbox"/>
RS exhaust system	<input type="checkbox"/>
Recuperation	<input type="checkbox"/>
Start-stop system	<input type="checkbox"/>
Airbags	<input type="checkbox"/>

Side airbags, front, and head airbag system	<input type="checkbox"/>
Side airbags, rear	<input checked="" type="checkbox"/>
Side impact protection in the doors	<input type="checkbox"/>
Integrated head restraint system	<input type="checkbox"/>
Seat belts	<input type="checkbox"/>
Seat belt reminder	<input checked="" type="checkbox"/>
Electrical child-proof lock for the rear doors	<input checked="" type="checkbox"/>
ISOFIX child seat mounting and top tether for the outer rear seats	<input type="checkbox"/>
ISOFIX child seat mounting for the front-passenger seat	<input checked="" type="checkbox"/>
First-aid kit	<input checked="" type="checkbox"/>
Warning triangle	<input checked="" type="checkbox"/>
Audi Extended Warranty	53
Audi Extended Warranty	<input checked="" type="checkbox"/>

Equipment for the Audi RS Q3 illustrated (p. 4–21):

Paint finish: Sepang blue, pearl effect







Wheels: cast aluminium wheels in 5-twin-spoke V design in matt titanium look, gloss turned finish*

Seats/seat upholstery: sport seats, front in Alcantara/leather, black

Inlays: carbon

Classifications of tyre parameters

The table shows the range of fuel efficiency, wet grip and exterior noise emission classes for the different tyre sizes of the Audi RS Q3.

	Tyre size	Fuel efficiency class	Wet grip class	Exterior noise emission class
Summer tyres	235/50 R 18	C	B	71 
	255/40 R 19	E–C	B	73–71 
	255/35 R 20	E	B	73–70  – 
Winter tyres	225/50 R 18	E–C	E–B	72–70 
	255/40 R 19	E–C	C–B	73–69  – 

It is not possible to order a specific tyre. Ask your Audi partner about the range of tyres available in your country.

Standard equipment Optional equipment

Country-specific variations possible. Please find out from your local Audi partner which equipment is standard and what optional equipment is available in your country.

More detailed descriptions of a selection of items from the equipment range can be found from page 34 onwards.

*Please note the special information relating to wheels on page 54.



Responsibility

Living up to our responsibilities is a principle that is firmly anchored in Audi strategy. Alongside commercial success and international competitiveness, our responsibility toward company employees and society as a whole is a key consideration, as is protecting the environment and conserving resources. And what is true in the details – our catalogues are printed on FSC-certified paper – also holds in general: Audi develops cars that are not only sporty and emotive but also ever more efficient. In the long run, Audi wants its products to allow CO₂-neutral

mobility. Seeing to it that production in Audi plants gradually becomes CO₂-neutral is another aspect of our comprehensive approach. Audi is also committed to society – particularly in the fields of education, technology and social projects. At Audi, sustainability is closely linked with how we see the future: the Audi Urban Future Initiative sees Audi working with international experts to get to the root of future urban challenges and trends in mobility.

Discover the world of Audi.



The Audi experience

The fascination of Audi can be experienced in many different ways. Audi City Berlin, Audi City London and Audi City Beijing, for example, give you digital access to all models at their actual size and in real time. And of course it is always worth visiting one of the major motor shows. This is where Audi always presents its new models and invites you to take a look at how the future is being shaped with "Vorsprung durch Technik". Anyone interested in seeing how Audi is already putting this into practice will find fascinating insight in the "Vorsprung durch Technik" online special at www.audi.com. But a look back can also be rewarding: at the Audi museum mobile in Ingolstadt, history and high-tech go hand in hand. A total of 130 historic exhibits and state-of-the-art



forms of presentation make for a thrilling symbiosis. Plus, Audi driving experience allows you to live the excitement and countless possibilities of current Audi models. Here, pure driving enjoyment is combined with valuable learning effects. This is ensured by a team of specially trained and highly qualified instructors who provide practical tips to help you optimise your driving skills. All this can now also be enjoyed at the recently opened Audi driving experience center in Neuburg, near Ingolstadt. Facilities here include a circuit of up to 3.4 kilometres that features challenging combinations of bends, a 30,000 m² dynamic driving area and an offroad section where Q models can be put through their paces.

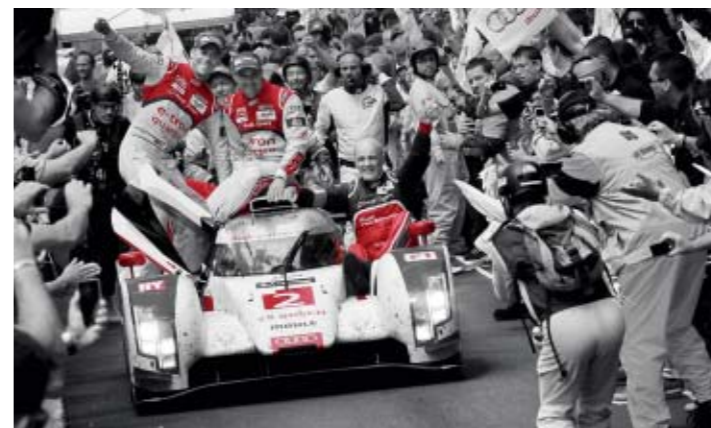

Choosing an Audi means choosing a brand that offers more. More individuality. More exclusivity. More fascination.



Team spirit

Motorsport is a driving force behind the brand. For years Audi has been among the champions in various racing series, for instance the 24 Hours of Le Mans or the DTM German Touring Car Masters. The values that are crucial in many different areas of sport are also central ones for Audi: precision, passion and technology. No coincidence then that Audi has been sponsoring sporting events for

many years. In the world of winter sports, for example, Audi has been the main sponsor of the German Ski Association (DSV) for almost three decades and has also partnered 16 other national alpine teams. In football, we support national and international teams. And Audi is also a partner for the German Olympic Sports Confederation.

www.audi.com

Information on all the topics mentioned above can be found on our website: www.audi.com.



www.audi.com



configurator.audi.com



www.audi.com/vorsprung-durch-technik



www.audi.com/driving



www.audi.com/cr

quattro GmbH
85045 Ingolstadt
www.audi.com
Valid from April 2015

Printed in Germany
558/1173.00.18



The models and equipment versions illustrated and described in this brochure and some of the services listed are not available in all countries. Some of the cars illustrated are equipped with optional features for which an extra charge is made. Details concerning the delivery specifications, appearance, performance, dimensions and weights, fuel consumption and running costs of the vehicle were correct to the best of our knowledge at the time of going to press. Deviations from the colours and shapes shown in the illustrations may occur. No liability is accepted for errors and printing errors. The right to introduce modifications is reserved. Not to be reproduced, including in part, without the written approval of AUDI AG.

This brochure is printed on paper made from pulp bleached without the use of chlorine.