



# RS 7

 Audi RS 7 Sportback

Vorsprung durch Technik 



|             | Page |                         |
|-------------|------|-------------------------|
| Fascination |      |                         |
|             | 4    | Audi RS7 Sportback      |
| Technology  |      |                         |
|             | 22   | Audi ultra              |
|             | 24   | V8 TFSI engine          |
|             | 26   | tiptronic               |
|             | 28   | quattro®                |
| Equipment   |      |                         |
|             | 38   | Style guides            |
|             | 40   | Paint finishes          |
|             | 42   | Wheels/tyres            |
|             | 44   | Seats/seat upholstery   |
|             | 47   | Inlays                  |
|             | 48   | Equipment packages      |
|             | 48   | Lights and mirrors      |
|             | 49   | Exterior equipment      |
|             | 50   | Interior equipment      |
|             | 51   | Infotainment            |
|             | 53   | Assistance systems      |
|             | 54   | Technology              |
|             | 55   | Audi Extended Warranty  |
| Other       |      |                         |
|             | 56   | Technical data          |
|             | 57   | Dimensions              |
|             | 58   | Index                   |
|             | 64   | The fascination of Audi |

The equipment for the vehicle illustrated in the Fascination section can be found on page 62.  
 The fuel consumption and CO<sub>2</sub> emission figures as well as the efficiency class can be found on page 56.

## Unconditional dynamism. With prestige.

■ Puristic elegance. Incredible power. Cutting-edge engineering. They all add up to produce a car that is simply without precedent: the Audi RS 7 Sportback.

The fuel consumption and CO<sub>2</sub> emission figures as well as the efficiency class can be found on page 56.





## Unconditional driving pleasure. With Audi cylinder on demand.

■ The 4.0 litre V8 TFSI engine generates 412 kW and delivers a maximum torque of 700 Nm. Pure power that the quattro permanent all-wheel drive transfers to the road with confidence. The sprint from 0 to 100 km/h is effortless and takes just 3.9 seconds. The RS 7 Sportback also excels when it comes to efficiency, with Audi cylinder on demand shutting down four of the eight cylinders in the partial-load range. The engine continues to run smoothly and powerfully regardless. The only difference is that fuel consumption and emissions are reduced.

The fuel consumption and CO<sub>2</sub> emission figures as well as the efficiency class can be found on page 56.



■ Less weight equals more driving pleasure. The intelligent Audi ultra lightweight technology improves the power-to-weight ratio and sharpens the handling dynamics. You are also assured of superb roadholding thanks to the standard RS adaptive air suspension. There is also the option of the RS sport suspension plus with Dynamic Ride Control (DRC) for a further reduction in the vehicle's pitching and rolling movements.

The fuel consumption and CO<sub>2</sub> emission figures as well as the efficiency class can be found on page 56.



## Unconditional athleticism. With elegance.

■ Elegance at its most powerful: the trademark Audi Singleframe featuring a matt aluminium-look frame and high-gloss black honeycomb grid creates an impression of outstanding strength. RS bumpers with large side air intakes and integrated flaps as well as the optional LED headlights with dark-tinted surrounds help to underline the individual character of the Audi RS 7 Sportback. The tornado line sets the tone for the side view's dynamic appearance, which is further emphasised by the distinctive widened sills. The trim strips and exterior mirror housings in matt aluminium look add some RS-specific touches.

The fuel consumption and CO<sub>2</sub> emission figures as well as the efficiency class can be found on page 56.





Unmistakably RS: the sporting traits of the Audi RS7 Sportback. The optionally available 21-inch cast aluminium wheels in 5-spoke blade design provide a clear view of the optional ceramic brake behind. The RS bumper with high-gloss black diffuser insert and integrated oval tailpipe trims brings the vehicle's dynamically styled rear to an impressive conclusion.

The fuel consumption and CO<sub>2</sub> emission figures as well as the efficiency class can be found on page 56.





▀ Keeping a firm grip on power: the shift paddles of the flat-bottomed RS leather-covered multifunction sport steering wheel enable you to change gear manually without having to let go of its rim's chunky contours. Meanwhile, the MMI® navigation plus with MMI touch gives you perfectly intuitive control over many vehicle functions. Meaning that you can enjoy the extraordinary driving experience even more intensely.

The fuel consumption and CO<sub>2</sub> emission figures as well as the efficiency class can be found on page 56.



▀ The interior exudes sportiness, exclusiveness and quality the moment you open the door. Details such as the illuminated door sill trims, pedals in aluminium look, door openers with a delicate double-bar design and carbon inlays all serve to underline the vehicle's premium character. The RS sport seats with their boldly contoured form offer excellent lateral support even on the most challenging drives. Optional seat upholstery in Valcona leather with honeycomb-patterned stitching in rock grey adds to the sporty, exclusive ambience.

The fuel consumption and CO<sub>2</sub> emission figures as well as the efficiency class can be found on page 56.





Not only does the Audi RS 7 Sportback boast a unique dynamism, the way in which it adapts to the driver is just as individual. Thanks to the 8-speed tiptronic's Dynamic Shift Program (DSP), the transmission can automatically adjust to your driving style. Fast, precise gear changes at exactly the right moment help you to drive just the way you like. What's more, the transmission's wide ratio spread serves to increase efficiency, too.

With Audi drive select you can also modify the vehicle's character at any time at the push of a button. From the engine to the suspension, a range of components and systems can be configured for an even sportier or a more balanced ride.

The fuel consumption and CO<sub>2</sub> emission figures as well as the efficiency class can be found on page 56.

■ Exclusive design. Unconditional dynamism. Experience all the fascination of an exceptional high-performance car – the Audi RS7 Sportback.

The fuel consumption and CO<sub>2</sub> emission figures as well as the efficiency class can be found on page 56.





Audi ultra on the podium: the Audi R18 ultra

# Audi ultra:

## Every gram less extends the lead.

Audi ultra, the pioneering lightweight technology from Audi, is more than just the sum of its individual components. It combines innovative materials, intelligent design principles and production processes that use resources sparingly into an overall concept. Many Audi ultra lightweight measures have already been implemented in the Audi RS 7 Sportback.

That starts with the body itself. The aluminium hybrid body combines low weight with high rigidity. The body is produced in a hybrid steel-aluminium design. This provides a high level of safety with an agile driving sensation – and

The fuel consumption and CO<sub>2</sub> emission figures as well as the efficiency class can be found on page 56.

reduced fuel consumption. The aluminium components on the front and rear axles as well as the lightweight forged aluminium wheels consistently implement this lightweight theme. New innovative wave brake discs with a wave-shaped contour and aluminium brake disc chambers specifically reduce the weight on the wheels. The resulting reduction in unsprung masses leads to improved rolling characteristics.

Technologies such as FSI® direct fuel injection and turbocharging have made Audi engines more and more powerful. The modern 4.0 litre V8 TFSI engine in the RS 7 Sportback produces more

power with less displacement and is therefore significantly lighter than similar engines in previous series.

Each lightweight component has an effect on other components, allowing their dimensions to be reduced as well. The result is a continuous development process towards less and less weight and more and more efficiency. In figures: a vehicle that weighs 100 kg less can save up to 0.3 litres of fuel per 100 km.

### About weight reduction

**The demands placed on modern vehicles are contradictory.** On the one hand, they must offer enhanced performance and comfort, on the other they need to be more economical and efficient. Audi ultra resolves this conflict by examining each and every component. We demand the highest functionality combined with the lowest possible weight. The result is an intelligent mix of materials that even allows a reduction in engine size: lighter vehicles no longer need a large engine to be agile. In 2012, for instance, both the Audi R18 e-tron quattro and the Audi R18 ultra drove to podium finishes at Le Mans with a V6 engine, whereas their victorious predecessor in 2010, the R15 TDI, had featured a V10 engine.

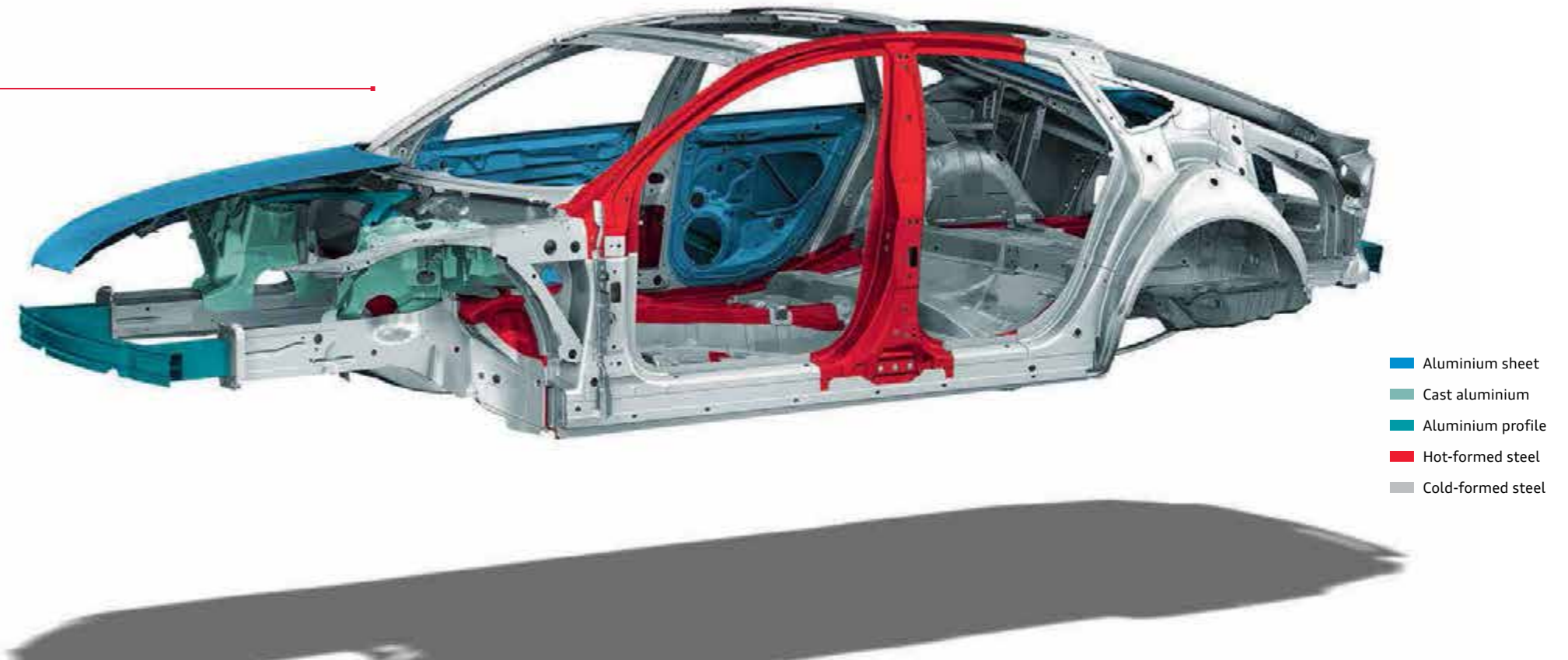

- Aluminium sheet
- Cast aluminium
- Aluminium profile
- Hot-formed steel
- Cold-formed steel



#### V8 engine with 3,993 cc of displacement

- maximum power output 412 kW at 5,700–6,600 rpm
- maximum torque 700 Nm at 1,750–5,500 rpm
- specific power output 103.2 kW/l of displacement
- turbocharging with up to 1.2 bar
- FSI direct fuel injection with up to 140 bar

## Intelligent power.

### Audi cylinder on demand in the TFSI® engine.

The Audi RS 7 Sportback has a V8 4.0 TFSI engine that features the innovative new Audi cylinder on demand. This ensures that during partial load operation, only four of the eight cylinders are used – without you noticing the difference. The engine always runs smoothly and powerfully, but it uses less fuel and emits less CO<sub>2</sub>.

We describe its mode of operation as “intelligent performance”. Audi cylinder on demand selectively closes certain cylinders, two per cylinder bank. As a result the engine runs impressively smoothly even during partial load operation. The deactivation

depends on several factors: the revs are between 960 and 3,500, the engine temperature must be at least 30 °C and you must be in at least third gear. If you then do not need the full power of eight cylinders, the Audi valvelift system closes the intake and outlet valves and switches off the injection and ignition of the corresponding cylinders. This means that neither is air taken in and fuel injected, nor is exhaust gas emitted. In other words: the consumption and emission values are noticeably improved.

In addition, the V8 4.0 TFSI engine features a start-stop system and recuperation, and it goes without saying that it complies with the EU5 emission standard.

Thanks to its very spontaneous responsiveness and exceptional power delivery across the entire engine speed range, the 8-cylinder engine promotes an impressive driving style. Its 412 kW accelerate the RS 7 Sportback at a torque of 700 Nm from 0 to 100 km/h in 3.9 seconds. The engine is electronically regulated at 250 km/h, but by request also at 280 or 305 km/h.

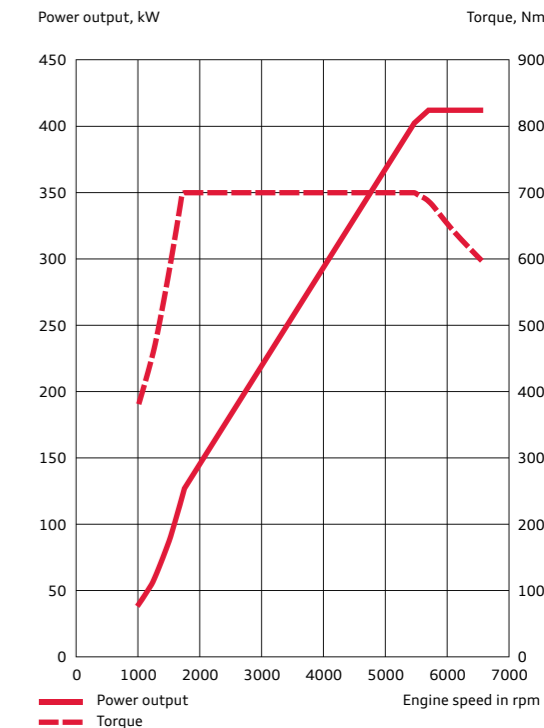

The fuel consumption and CO<sub>2</sub> emission figures as well as the efficiency class can be found on page 56.

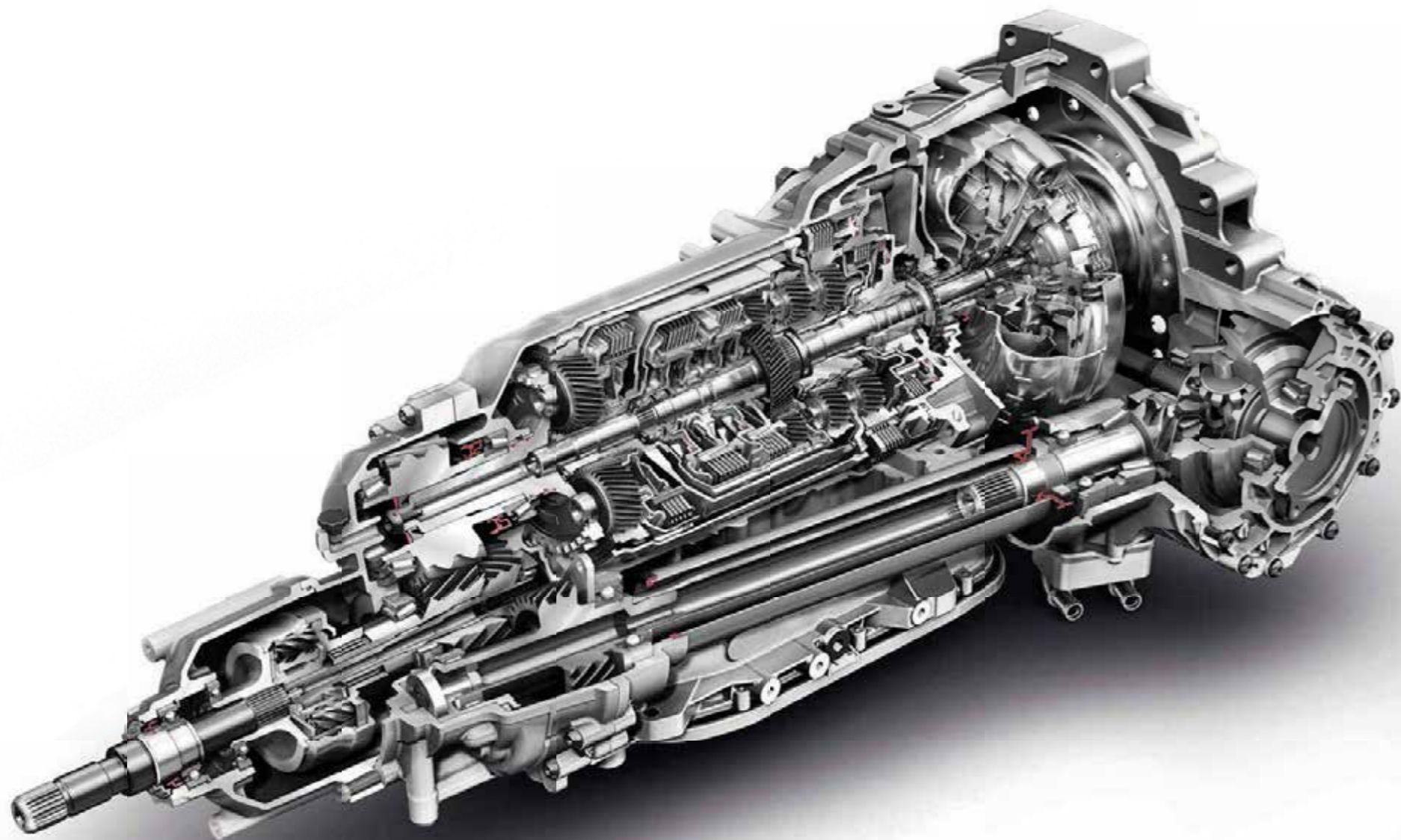

## When does the tiptronic change to the next gear?

At just the right time.

A high-performance vehicle needs an appropriate transmission. Which is why the Audi RS 7 Sportback has an automatic transmission that stands out due to fast gear changes and a high degree of efficiency.

The 8-speed tiptronic transmission enables spontaneous, highly flexible gear changes. Its wheel set concept with four wheel sets requires only five gear change elements, of which two are opened in each gear. Three multi-plate clutches and two brakes work with a high degree of efficiency – or, put another way: with particularly short gear change times.

The gear changes occur within the optimal speed range – this reduces power flow losses and allows you to move with agility. The Dynamic Shift Program (DSP) determines the suitable gear changing point itself, and adapts to your individual driving style. The DSP accesses route data in the standard MMI navigation plus with MMI touch. This way it can include corners in its shifting strategy and avoid unnecessary gear changing. Along with the Drive mode (D), the additional Sport program (S) offers a sportier driving style using gear change points that are set later. You can influence manual gear changes at any time with the shift paddles on the steering wheel or by

briefly touching the gear lever, for example for more dynamic performance or to drop gears for enhanced engine braking on winding, hilly roads.

With its cleverly designed gear changing mechanism and the large transmission-ratio spread, the tiptronic helps to reduce consumption and emission values and combines comfort while changing gear and driving off with impressive driving dynamics.

The fuel consumption and CO<sub>2</sub> emission figures as well as the efficiency class can be found on page 56.

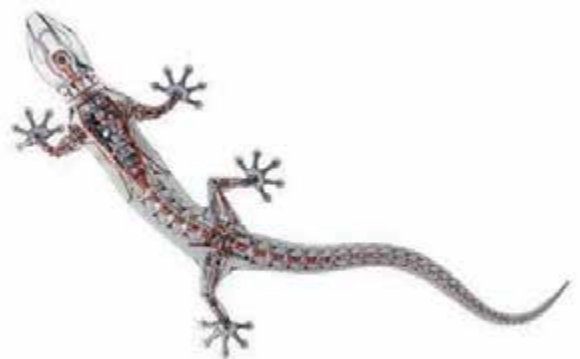

## Why only use two wheels when a car has four?

### The quattro® permanent all-wheel drive.

Those who know Audi know quattro. And once you have driven with the permanent all-wheel drive from Audi, you won't drive with anything else. Why? Because almost no other drive system around transfers engine power to the road so directly.

The central component of the quattro drivetrain on the Audi RS 7 Sportback is the self-locking centre differential. With its consistent light-weight construction, a weight advantage has been achieved over the previous version. The

purely mechanical planetary transmission distributes the drive torques asymmetrically between the front and rear axle in a 40:60 ratio for better driving dynamics in the basic design. But if necessary up to 70% can be distributed to the front or up to 85% to the rear to offset any occurring wheel slip.

In conjunction with the wheel-selective torque control, the drive force is distributed to each individual wheel according to the driving situation. What is special here is the way the effects of the

torque distribution are felt before undesirable wheel slip occurs. This allows a yaw moment to be produced, which supports cornering.

The result is precisely controlled and sporty handling with increased agility and superb traction at the same time.

By request the quattro drivetrain can be fitted with sports differential on the rear axle, in order to further enhance driving dynamics.

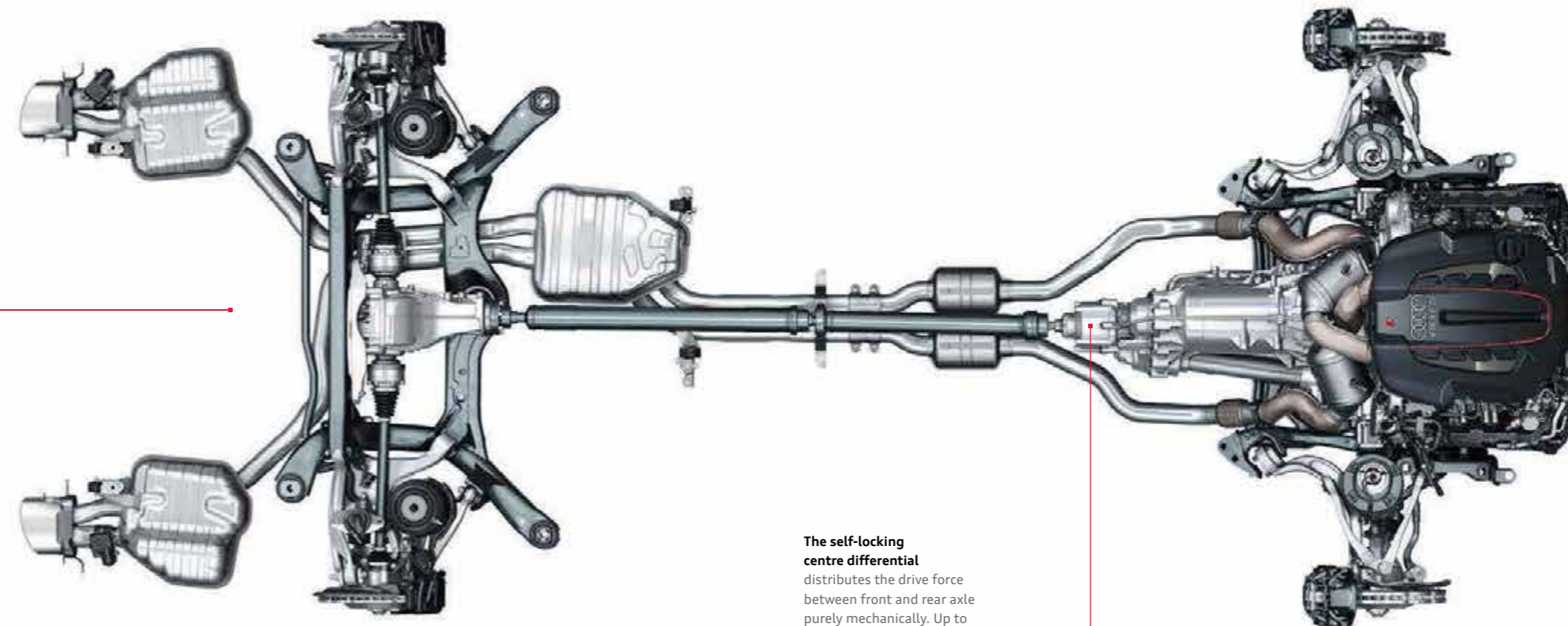

**The self-locking centre differential** distributes the drive force between front and rear axle purely mechanically. Up to 70% to the front axle and up to 85% to the rear axle, as required.

# Dynamic. Sporty. Self-assured.

## Your suspension shows plenty of character.

Whether on long journeys or quick trips, the RS adaptive air suspension gives the Audi RS 7 Sportback excellent road handling while giving you poise. It combines precise steering characteristics, outstanding grip and high agility.

The front axle features a 5-link design, while the rear axle follows the self-tracking trapezoidal link principle. Many vehicle components are made of aluminium to reduce weight and keep the unsprung masses low.

The RS adaptive air suspension combines air suspension with a variably adaptive damper system. Sensors on the body and on the axles monitor the current driving situation and send

information to the system during the journey. This suspension also allows for various trims on the vehicle and simultaneously acts as a level regulator so that driving features are not compromised even with a heavy load.

The RS sport suspension plus with Dynamic Ride Control (DRC) is available as an option. With this suspension variant with steel springs and shock absorbers with variable characteristics, the nodding and pitching movements of the vehicle around the lateral and longitudinal axes are reduced purely by hydraulic means. The diagonal dampers are connected to one another via oil pipes and one central valve each. If the dampers are immersed differently, for example during fast cornering, the valves affect the oil flow on the

cushioned wheel. They increase support there, thus reducing side tilt and enhancing driving dynamics.

With Audi drive select you can select different modes to adjust the damper properties of the suspension and, in the case of RS adaptive air suspension the trim of your vehicle. The damper recognition however can be varied in three stages: comfort, auto and dynamic. Depending on the setting selected, both suspensions offer a wide scope for any route and for your driving style.

In order to do justice to the dynamic demands made of a high-performance vehicle, the characteristic curves of the springs and dampers,

as well as the rigidity of the tubular stabilisers, have been developed and put through their paces in an extensive series of tests, including some conducted on racing tracks.

Equally, the electromechanical power steering was given a specific characteristic curve as part of its adaptation to the Audi RS 7 Sportback. It works with variable steering support, depending on the speed. Thanks to the low-position configuration, the steering forces are conducted just a short distance to the wheels, which provides a spontaneous steering response and gives you precise feedback from the road. Since the steering requires almost no energy when driving in a straight line, it also helps to reduce fuel consumption.

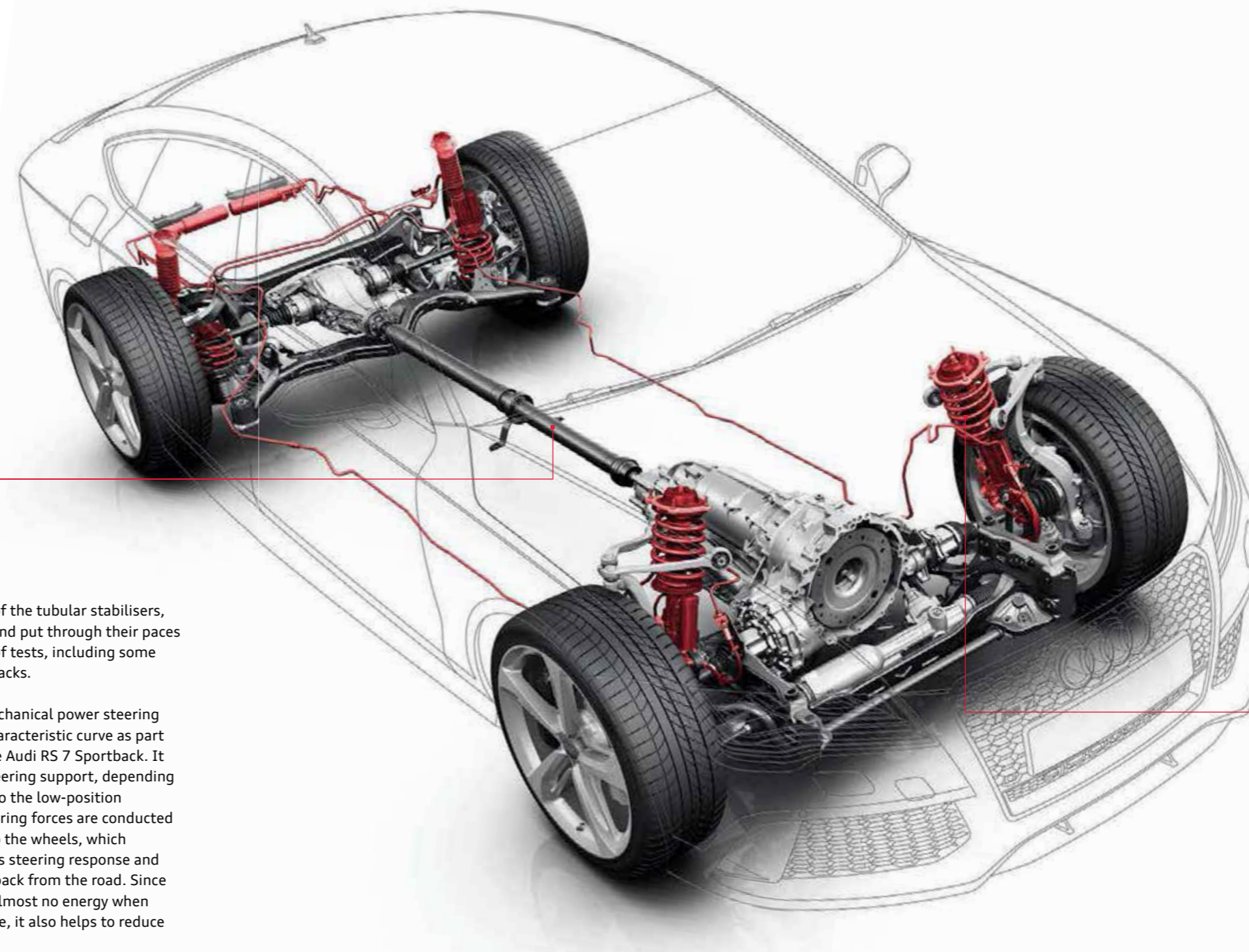

### RS sport suspension plus with Dynamic Ride Control (DRC)

Thanks to the hydraulic links between the diagonal shock absorbers, the nodding and pitching movements of the vehicle are reduced, leading to enhanced drive dynamics. The damper recognition can be varied in 3 stages via Audi drive select: comfort, auto, dynamic.

# Nothing can stop a top athlete.

Except for a top brake system.



The standard 19-inch RS brake system takes a powerful hold with its 6-piston fixed callipers on the front axle. The wave brake discs comprise a cast friction ring with a wave-shaped outer contour, which is connected to the aluminium brake disc chamber by means of steel pins. This so-called floating mounting ensures that the friction ring remains tension-free to a major extent, improving stability under high temperature loads. In addition, the axial perforation and cooling channels for internal ventilation improve the performance of the brake discs. The use of aluminium and the characteristic geometry of the friction rings reduce the weight of the brake discs, thus improving the balance of unsprung masses.

The optional 20-inch ceramic brake\* is available for even more demanding loads. With this brake system, the brake discs are made of a carbon-fibre reinforced ceramic material which is based on hard and abrasion-proof silicon carbide with embedded high-strength carbon fibres. This combination results in an enormous abrasion resistance which allows extremely high mileages to be achieved, while reducing sensitivity to high thermal loads. In addition, the material is lighter than steel discs.

20-inch ceramic brake\*

19-inch RS brake system

The brake discs on the front axle have a diameter of 390 mm and a wave-shaped outer contour. The high-gloss black painted brake callipers bear the RS logo.

The brake discs on the front axle have a diameter of 420 mm. The high-gloss anthracite painted brake callipers bear the "Audi ceramic" logo.

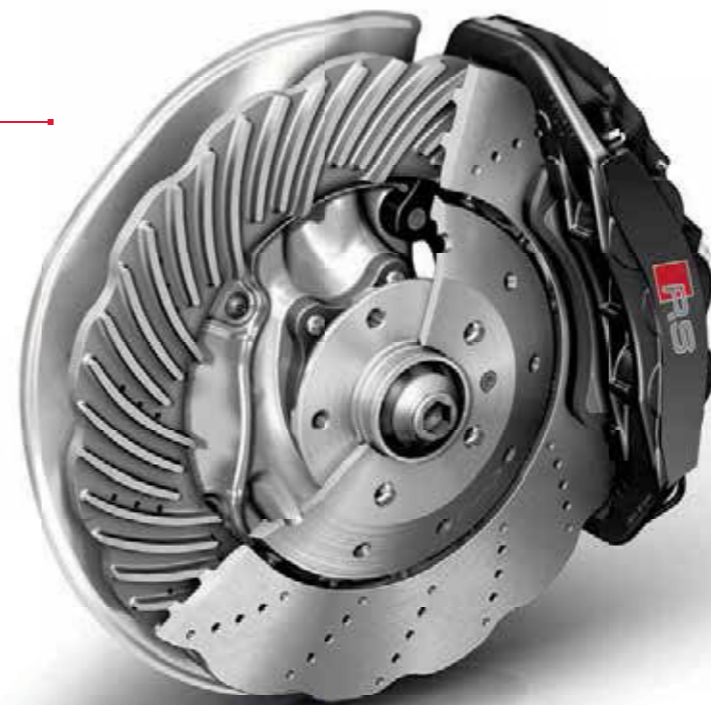

\*Please consult your Audi partner or national Audi website to find out more about the special features of the ceramic brake.

Why does the Audi RS 7 Sportback suit you so well? Because it adapts itself to you so well.

Audi drive select.



comfort



dynamic



auto



individual

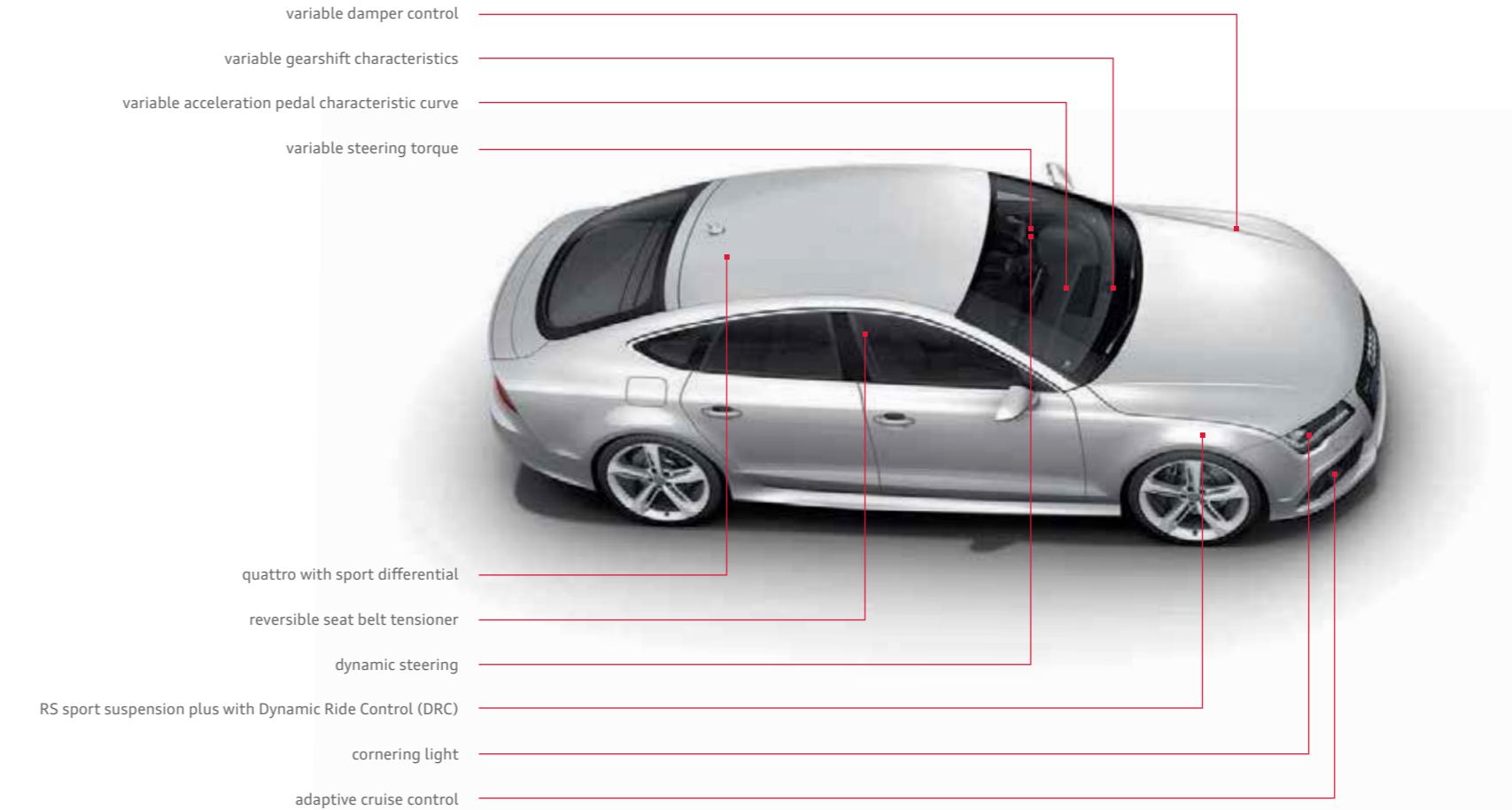

With the standard Audi drive select you can influence individual vehicle components at the push of a button and so change the character of your Audi RS 7 Sportback. Generally speaking, the accelerator pedal characteristic curve, exhaust flap control, gear mode, damper regulation of the RS adaptive air suspension and the steering torque of the electromechanical power steering can be configured.

You have four modes available to adapt these components to the individual driving situation.

The fuel consumption and CO<sub>2</sub> emission figures as well as the efficiency class can be found on page 56.

Auto mode is the setting that defines the superior sporty quality of the Audi RS 7 Sportback. Comfort mode is particularly suitable for longer distances, whereas dynamic mode is designed for more ambitious driving. In individual mode you can configure the individual components yourself.

In addition, various optional systems can be influenced. For example, the characteristic curves of the shock absorbers on the RS sport suspension plus with Dynamic Ride Control (DRC) can be

varied in three levels: from balanced rolling in comfort mode through to sporty, direct responsiveness in the dynamic setting.

The optional dynamic steering allows the steering ratio and support to be changed depending on driving speed and the Audi drive select mode selected.

In conjunction with the equipment version quattro® with sport differential, an additional infinitely variable distribution of the drive forces

between the rear wheels takes place. This torque manipulation specifically influences the vehicle's steering behaviour and increases agility even further, in line with the Audi drive select setting.

The cornering light function of the adaptive light or the reactions of the adaptive cruise control can also be set to be either more gradual or more spontaneous. In dynamic mode the trigger thresholds of the reversible seat belt tensioners (with Audi pre sense basic series onward) can also be adjusted.



It is the equipment that turns an Audi into your Audi.

Style guides: a wide choice of possible combinations. Here are two of them.



**Audi RS 7 Sportback in panther black, crystal effect**

Cast aluminium wheels in 5-spoke blade design in matt titanium look, high-gloss turned finish

Matt aluminium design package including funnel-shaped air intake with quattro logo

Inlays in aluminium/Beaufort, black

RS sport seats, front, in Valcona leather, lunar silver with honeycomb-patterned stitching in rock grey

RS leather-covered multifunction sport steering wheel in 3-spoke design



**Audi RS 7 Sportback in Suzuka grey, metallic**

Cast aluminium wheels in 5-spoke blade design in high-gloss black, high-gloss turned finish

Carbon design package including funnel-shaped air intake with quattro logo

Inlays in carbon

RS sport seats, front, with design package in Valcona leather, black, with honeycomb-patterned stitching in Audi exclusive crimson red

Controls in black perforated leather with stitching in Audi exclusive crimson red (part of the design package)





Daytona grey, pearl effect

Solid/metallic paint finishes



Ibis white



Nardo grey



Suzuka grey, metallic

Pearl effect paint finishes



Daytona grey, pearl effect



Misano red, pearl effect



Phantom black, pearl effect

Crystal effect paint finishes



Prisma silver, crystal effect



Estoril blue, crystal effect



Panther black, crystal effect

Matt effect paint finish

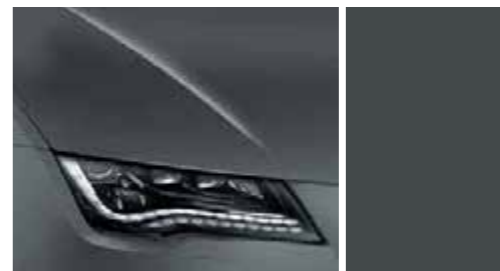

Daytona grey, matt effect

Customised paint finishes



Audi exclusive customised paint finishes



Cast aluminium wheels in 5-spoke blade design

#### Wheels/tyres



**Forged aluminium wheels**  
in 7-twin-spoke design, high-gloss turned finish  
size 9 J x 20 with 275/35 R 20 tyres\*



**Cast aluminium wheels**  
in 5-spoke blade design in matt titanium look,  
high-gloss turned finish  
size 9 J x 21 with 275/30 R 21 tyres\*



**Cast aluminium winter wheels**  
in 7-twin-spoke design  
size 8 J x 20 with 245/40 R 20 winter tyres\*,  
can be fitted with snow chains,  
permissible top speed 240 km/h



**Cast aluminium wheels**  
in 5-spoke blade design  
size 9 J x 21 with 275/30 R 21 tyres\*



**Cast aluminium wheels**  
in 5-spoke blade design in high-gloss black,  
high-gloss turned finish  
size 9 J x 21 with 275/30 R 21 tyres\*



**Cast aluminium winter wheels**  
in 5-spoke blade design  
size 9 J x 21 with 275/30 R 21 tyres\*,  
cannot be fitted with snow chains,  
permissible top speed 270 km/h

#### Anti-theft wheel bolts

can only be loosened using adapter provided

#### Tyre repair kit

with 12V compressor and tyre sealant, located under the loading floor cover in the luggage compartment; permissible top speed 80 km/h

#### Tyre pressure monitoring system

monitors the air pressure set in the tyres and the tyre temperature throughout the journey, also works with winter wheels delivered by Audi; air pressures and temperatures of the individual tyres can be displayed in the MMI system

#### Vehicle tool kit

in the luggage compartment

#### Vehicle jack

in the luggage compartment



**RS sport seats, front**  
with shaped seat side bolsters for better lateral support, integrated head restraints and RS 7 embossing on the front-seat backrests; with manual adjustment of seat height, fore/aft position, seat angle, backrest angle as well as belt height; electric 4-way lumbar support; extendable thigh support  
(The image shows RS sport seat, front, electrically adjustable, in Valcona leather, black with honeycomb-patterned stitching in rock grey.)

Leather upholstery and trim



Alcantara/leather, black  
with diamond-patterned stitching in black

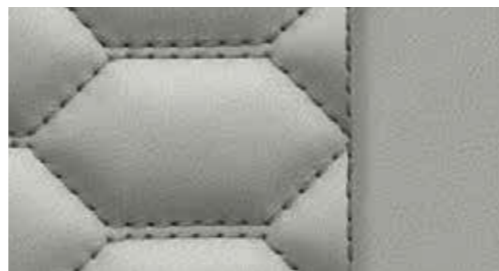

Valcona leather, lunar silver  
with honeycomb-patterned stitching in rock grey

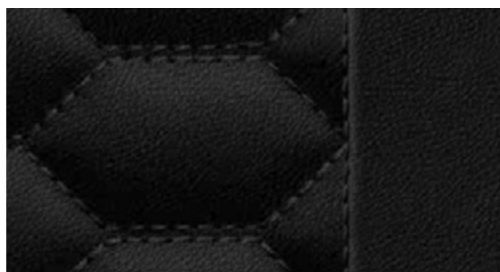

Valcona leather, black  
with honeycomb-patterned stitching in black



Audi exclusive Valcona leather, black  
with honeycomb-patterned stitching in crimson red

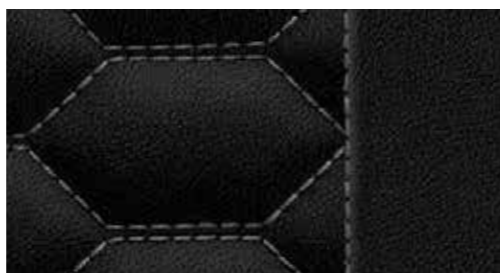

Valcona leather, black  
with honeycomb-patterned stitching in rock grey



Audi exclusive leather upholstery and trim.



**Comfort seats, front, with memory function**  
with electric adjustment of seat height, fore/aft position, backrest angle, seat angle and thigh support; pneumatic adjustment of seat and backrest side bolsters as well as lumbar support; manual adjustment of head restraint height and clearance, as well as seat belt height; including memory function for driver and front-passenger seat, electric steering wheel adjustment and exterior mirrors; optional seat ventilation, front  
(The image shows comfort seat, front, with memory function and seat ventilation, front, in perforated Valcona leather, black.)

Leather upholstery and trim



Milano leather, black



Audi exclusive leather upholstery and trim.

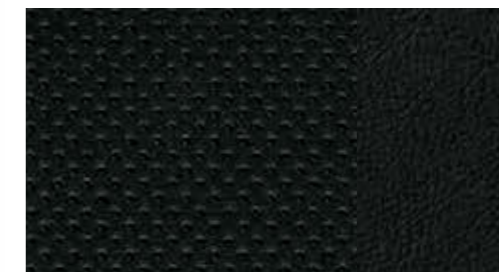

Perforated Valcona leather, black

**Leather upholstery and trim****Alcantara/leather combination**

available for RS sport seats, front: seat centre panels and door trim inserts in Alcantara; seat side bolsters, head restraints, front centre armrest and lower part of centre console in leather; seat centre panels on the front and rear seats with diamond-patterned stitching; RS 7 embossing on the front-seat backrests

**Milano leather**

available for comfort seats, front, with memory function without seat ventilation, front: seat upholstery, head restraints, door trim inserts, front centre armrest and lower part of centre console in leather

**Valcona leather with honeycomb-patterned stitching**

available for RS sport seats, front: seat upholstery, head restraints, door trim inserts, front centre armrest and lower part of centre console in leather; seat centre panels on the front and rear seats with honeycomb-patterned stitching; RS 7 embossing on the front-seat backrests

**Perforated Valcona leather**

available for comfort seats, front, with memory function and seat ventilation, front: seat upholstery, head restraints, door trim inserts, front centre armrest and lower part of centre console in leather; perforated seat centre panels on the front and rear seats

**Leather-covered armrests in the door trims**

with contrasting stitching in rock grey in conjunction with Valcona leather with honeycomb-patterned stitching in rock grey

**Leather-covered steering wheel airbag cover**

available for RS leather-covered multifunction sport steering wheel and leather-covered multifunction sport steering wheel, heated: in leather, black

**Audi exclusive leather package including airbag cover**

armrests in the door trims, lower part of centre console and steering wheel airbag cover leather-covered; individual choice of colours for the leather and the decorative stitching from the Audi exclusive colour range. In conjunction with RS leather-covered multifunction sport steering wheel, flattened at the bottom, without leather-covered airbag cover

**Extended Audi exclusive leather package**

dashboard underside including glove compartment and storage on the driver side, armrests in the door trims, centre console and lower part of centre console in leather. Individual choice of colour for leather and decorative stitching from the Audi exclusive colour range; steering wheel airbag cover in black leather; in conjunction with RS leather-covered multifunction sport steering wheel, flattened at the bottom, without leather-covered airbag cover

**Audi exclusive leather upholstery and trim in Alcantara/Valcona leather (package 1)**

available for RS sport seats, front: seat side bolsters, head restraints, front centre armrest and lower part of centre console in leather; seat centre panels on the front and rear seats with diamond-patterned stitching, as well as door trim inserts in Alcantara; RS 7 embossing on the front-seat backrests. Individual choice of colours for the leather, Alcantara and decorative stitching from the Audi exclusive colour range.

**Audi exclusive leather upholstery and trim in Valcona leather (package 1)**

available for comfort seats, front, with memory function: seat upholstery, head restraints, door trim inserts, centre armrest, front and lower part of centre console in leather. Individual choice of colours for the leather and the decorative stitching from the Audi exclusive colour range.

**Audi exclusive leather upholstery and trim in Valcona leather (package 2)**

available for comfort seats, front, with memory function, in addition to package 1: armrests in the door trims and seat backrest covers leather-covered, seat attachments matched to the leather colour. Individual choice of colours for the leather and the decorative stitching from the Audi exclusive colour range.

**Piping for Audi exclusive comfort seats**

individual choice of colour for piping from the Audi exclusive colour range. (Can only be ordered in conjunction with Audi exclusive Valcona leather upholstery and trim package 1 or package 2.)

**Audi exclusive leather upholstery and trim in Valcona leather with honeycomb-patterned stitching (package 1)**

available for RS sport seats, front: seat upholstery, head restraints, door trim inserts, front centre armrest and lower part of centre console in leather; seat centre panels on the front and rear seats with honeycomb-patterned stitching; RS 7 embossing on the front-seat backrests. Individual choice of colours for the leather and the decorative stitching from the Audi exclusive colour range.

**Audi exclusive leather upholstery and trim in Valcona leather with honeycomb-patterned stitching (package 2)**

available for RS sport seats, front, in addition to package 1: armrests in the door trims and seat backrest covers leather-covered, seat attachments matched to the leather colour. Individual choice of colours for the leather and the decorative stitching from the Audi exclusive colour range.

**Audi exclusive design package in Valcona leather with honeycomb-patterned stitching**

available for RS sport seats, front: seat upholstery, head restraints, door trim inserts, front centre armrest, armrests in the door trims and lower part of centre console in black leather with crimson red stitching; seat centre panels on the front and rear seats with honeycomb-patterned stitching in crimson red; RS 7 embossing on the front-seat backrests; including floor mats in black with leather piping in crimson red, controls with crimson red stitching and seat belts in crimson red



Carbon

**Inlays**

full-surface for the dashboard, centre console, door trims and all-round inlay; surrounds for the all-round inlay, door trims and centre console in aluminium look; without surrounds in aluminium look for inlays in aluminium Race and matt brushed aluminium

**Audi exclusive inlays**

available in fine grain ash, nougat, oak sepia, fine grain myrtle, nutmeg, vavona, bronze, Modrone, gold, tamo ash, natural dark brown

**Inlays**

Carbon

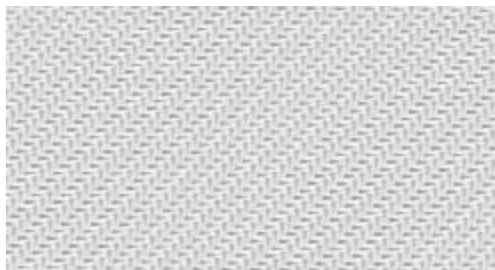

Aluminium Race

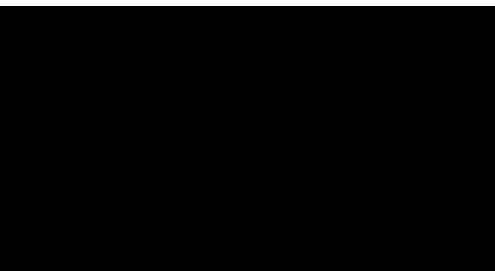

Piano finish, black

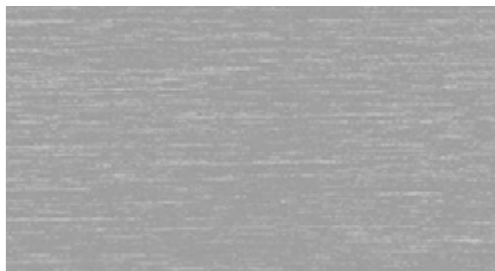

Matt brushed aluminium



Aluminium/Beaufort, black

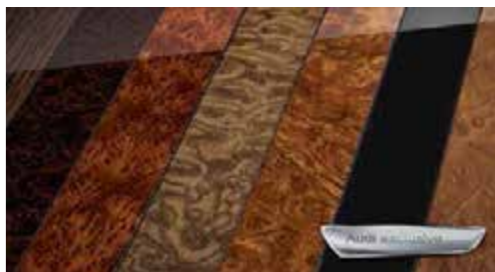

Audi exclusive inlays

| Equipment packages                                                                                                                                                                                                                                                                                                                                                                                                                                               |
|------------------------------------------------------------------------------------------------------------------------------------------------------------------------------------------------------------------------------------------------------------------------------------------------------------------------------------------------------------------------------------------------------------------------------------------------------------------|
| <b>Convenience package</b> including: <ul style="list-style-type: none"><li>Front seats, electrically adjustable with memory function for the driver seat</li> <li>Seat heating, front and rear</li> <li>Exterior mirrors, electrically adjustable, heated and folding, automatically dimming, with memory function</li> <li>Interior mirror, automatically dimming</li> <li>75 l fuel tank</li> <li>Audi music interface</li> <li>BOSE surround sound</li></ul> |

| Dynamic package                                                                                                                                                                                                                                                                                                            |
|----------------------------------------------------------------------------------------------------------------------------------------------------------------------------------------------------------------------------------------------------------------------------------------------------------------------------|
| including: <ul style="list-style-type: none"><li>Dynamic steering</li> <li>quattro with sport differential</li> <li>RS sport suspension plus with Dynamic Ride Control (DRC)</li> <li>Electronic regulation of the top speed at 280 km/h</li> <li>LED headlights</li> <li>Interior mirror, automatically dimming</li></ul> |

| Dynamic package plus                                                                                                                                                                                                                                                                                                                              |
|---------------------------------------------------------------------------------------------------------------------------------------------------------------------------------------------------------------------------------------------------------------------------------------------------------------------------------------------------|
| including: <ul style="list-style-type: none"><li>Ceramic brake</li> <li>Dynamic steering</li> <li>quattro with sport differential</li> <li>RS sport suspension plus with Dynamic Ride Control (DRC)</li> <li>Electronic regulation of the top speed at 305 km/h</li> <li>LED headlights</li> <li>Interior mirror, automatically dimming</li></ul> |

| Light                                                                                                                                                                                                                                                                                                                                                                                                                                                                                                                                               |
|-----------------------------------------------------------------------------------------------------------------------------------------------------------------------------------------------------------------------------------------------------------------------------------------------------------------------------------------------------------------------------------------------------------------------------------------------------------------------------------------------------------------------------------------------------|
| <b>xenon plus</b> <p>The headlights utilising durable gas discharge technology for dipped and high beam ensure intensive illumination of the road and provide good uniformity and range, both close up and in the distance; including all-weather light. The automatic dynamic headlight beam control reduces dazzle for oncoming traffic; including homogeneous rear light and daytime running light strip, indicators and brake lights as light strip, all in LED technology with low power consumption; including headlight cleaning system.</p> |

**adaptive light including variable headlight range control**

consisting of dynamic cornering light, static turning light and variable headlight range control; the dynamic cornering light infers the course of the road from the movement of the steering wheel and variably illuminates the bend by pivoting the xenon headlights; operational between speeds of approximately 10 km/h and 110 km/h. The static turning light automatically switches on if the indicators have been engaged for a while at a low vehicle speed and illuminates the new direction in which the vehicle is travelling. The variable headlight range control features a camera on the interior mirror which registers sources of light from other road users. The range and width of the headlight beam are continuously varied between dipped and high beam to suit ambient conditions, ensuring that the headlights provide good visibility without dazzling other road users. The headlights also have 3 different light distribution modes which are activated according to the vehicle speed: town light, motorway light and country light. In addition, Audi connect enables controlling of these 3 light distribution modes and the intersection light by the vehicle support system based on navigation data, and with the aid of stored route data from the MMI navigation plus with MMI touch. The convenient functions of the lighting assistant are supplemented by the travel mode, with GPS-assisted switching between right and left-hand drive modes. Including headlight cleaning system

**LED headlights** featuring dipped beam, high beam, daytime running lights, indicators, static turning light, all-weather light and motorway light function in LED technology; dark-tinted headlight surrounds; includes high-beam assist for automatic switching between high and dipped beams, an all-weather light function to reduce the risk of the driver being dazzled when visibility is poor (in fog, rain or snow) and an additional motorway light which automatically increases headlight range from a speed of approximately 110 km/h. The LED technology allows near daylight illumination of the road for increased safety and comfort. Minimal energy requirements, long service life, and excellent recognition by other road users; including headlight cleaning system

**High-beam assist** Working within system limits, it automatically detects the headlights of oncoming traffic, the rear lights of other road users and built-up areas. Depending on the traffic situation, the high beam automatically adjusts to dipped beam and vice versa.

**LED rear lights** with dark-tinted surrounds; brake lights, tail lights, rear fog lights and indicators, as well as rear number plate lights in LED technology; faster activation means earlier recognition by the driver behind; reversing lights in white, third high-mounted brake light in the rear window

**Adaptive brake light** brake light flashes during emergency braking to warn following traffic; hazard warning lights are activated automatically when the vehicle comes to a stop

**Light/rain sensor** to control the automatic headlights, the windscreen wipers and the coming home/leaving home function: delayed switching-off/automatic switching-on of the main headlights, rear and number plate lights, as well as the LED daytime running lights when parking/ opening the vehicle

**Ambient lighting** with delayed switch-off and contact switches on all doors, glove compartment and luggage compartment lighting, plus courtesy lighting in the tailgate, active door reflectors; LED technology for courtesy lighting on the underside of the door handles and door handle lighting to facilitate entry and exit in the dark as well as entrance lighting at the front and rear; anti-glare illumination for the passenger compartment in LED technology:

- 2 reading lights each at front and rear
- Lighting for door pockets, inside door handles, vanity mirrors and footwells
- Ambient reflected lighting for centre console and rear inner panels to help occupants better orient themselves
- Surround lighting for centre console
- Including integrated eyewear compartment in roof module; ambient lighting can be configured via MMI

| Mirrors                                                                                                                           |
|-----------------------------------------------------------------------------------------------------------------------------------|
| <b>Exterior mirrors with integrated LED indicator</b> electrically adjustable and heated, convex, flat or aspherical mirror glass |

also optionally:

**electrically adjustable and heated, with memory function** including automatic kerb-side function for the exterior mirror on the passenger side

**electrically adjustable, heated and folding, with memory function** including automatic kerb-side function for the exterior mirror on the passenger side

**electrically adjustable, heated and folding, automatically dimming, with memory function** including automatic kerb-side function for the exterior mirror on the passenger side

The automatic kerb-side function tilts the exterior passenger mirror downwards when reverse gear is engaged, giving the driver a better view of the kerb.

| Exterior mirror housings      |
|-------------------------------|
| choice of:                    |
| <b>in matt aluminium look</b> |
| <b>painted in body colour</b> |
| <b>in carbon</b>              |
| <b>Interior mirror</b>        |
| optionally:                   |
| <b>dimming</b>                |

**automatically dimming** recognises with the aid of a photocell when the head-lights behind are too bright and dims automatically

| Roof system                                                                                                                                                                                                               |
|---------------------------------------------------------------------------------------------------------------------------------------------------------------------------------------------------------------------------|
| <b>Slide-and-tilt glass sunroof</b> electric, with tinted single-glazed safety glass and infinitely adjustable sun shield, integrated wind deflector, convenience closing/opening from outside via the remote control key |

| Closing systems                                                                                                                                               |
|---------------------------------------------------------------------------------------------------------------------------------------------------------------|
| <b>Remote control key</b> unlocks and locks doors, luggage compartment lid and tank flap; includes convenience closing/opening of the windows; with RS emblem |

**Engine start-stop button** The engine is started and switched off via the engine start-stop button in the centre console; the key only needs to be carried with you.

**Convenience key** Access and drive authorisation system, the key only needs to be carried with you; the vehicle is locked and unlocked from outside via sensors on all door handles. When the vehicle is locked, the luggage compartment lid can still be openend separately.

**Luggage compartment lid, electrically opening and closing** opening via the button on the remote control key, button on the driver’s door panel, soft touch button in the luggage compartment lid handle recess, or by a kicking motion with the foot in conjunction with the optional convenience key including sensor-controlled luggage compartment release; closing via button on inside of luggage compartment lid, the button in the driver’s door or via the optional convenience key (long press); including power-assisted closing and programmable luggage compartment lid opening angle

**Convenience key including sensor-controlled luggage compartment release** Access authorisation system: the key only needs to be carried with you; the vehicle is locked and unlocked from outside via sensors on all 4 door handles. On detection of a specific foot gesture (kicking motion), a sensor in the rear bumper initiates a convenience key search in the rear area of the vehicle. When the key is detected, this opens the luggage compartment lid. For extra comfortable loading of the luggage compartment.

**Power-assisted door closing** automatically pulls doors that are not completely engaged into the locks

**Garage door opener (HomeLink)** programmable radio-operated remote control, operating buttons incorporated into the front roof module; can be used to open many garage doors and exterior gates; allows control of security and lighting systems; step-by step programming assistance provided by the MMI, code identification guidance and set-up assistance from appropriate logbook information on the screen, well integrated with the MMI to make it user friendly. For information on compatible hand-held transmitters, please contact your Audi partner or visit www.eurohomelink.com.

**Anti-theft alarm** with tow-away protection via angle of inclination sensors (can be switched off); including interior monitoring system which can be switched off; signal horn independent of vehicle electrical system; for monitoring doors, bonnet and tailgate

**Preparation for tracking system** preparation for connecting a tracking system (available from Audi Genuine Accessories) that enables a stolen vehicle to be located

| Glazing                                                                                                              |
|----------------------------------------------------------------------------------------------------------------------|
| <b>Heat-insulating glass</b> green tinted; windscreen made of laminated glass; rear window heated, with timer switch |

**Insulating/acoustic glass** 2 panes of glass bonded together by a plastic film; improves exterior noise insulation and theft protection; with additional reflective coating to reduce the build-up of heat in the interior; windscreen with viewing window for toll collection devices

**Dark-tinted windows (privacy glazing)** dark-tinted rear window, rear door windows and rear side windows

**Insulating/acoustic glass and dark-tinted windows (privacy glazing)** windscreen and front door windows in insulating/acoustic glass; dark-tinted rear window, rear door windows and rear side windows; windscreen with viewing window for toll collection devices

**Sun visors** for driver and front passenger; can be folded and swivelled; with illuminated vanity mirror that can be covered

**Sun screen** in the luggage compartment cover, can be erected, in black cloth

| Further exterior equipment                                                                                                      |
|---------------------------------------------------------------------------------------------------------------------------------|
| <b>Trim strips</b> window capping and roof frame trim strips in matt aluminium look, exterior B-pillar trim in high-gloss black |

**Audi Singleframe** radiator grille with honeycomb-design grid in high-gloss black and one-piece trim frame in matt aluminium look

**RS bumpers** in a sporty dynamic design; at the front with large air inlets and side flaps in high-gloss black as well as front spoiler in matt aluminium look, at the rear with diffuser insert in high-gloss black

**Matt aluminium design package including funnel-shaped air intake with quattro® logo** side flaps and top edge of the rear diffuser insert in matt aluminium look; including funnel-shaped air intake in the Audi Singleframe in matt aluminium look with quattro logo in titanium grey

**Carbon design package including funnel-shaped air intake with quattro® logo** front spoiler, side flaps and rear diffuser insert in carbon; including funnel-shaped air intake in the Audi Singleframe in carbon with quattro logo in titanium grey; frame of the radiator grille, radiator grille, as well as window slot and roof frame trim strips in high-gloss black

|                                                           |
|-----------------------------------------------------------|
| <b>RS exhaust system</b>                                  |
| dual-branch design with chrome-plated oval tailpipe trims |

|                                                                                                   |
|---------------------------------------------------------------------------------------------------|
| <b>RS sport exhaust system</b>                                                                    |
| dual-branch design with high-gloss black oval tailpipe trims; for an enhanced acoustic experience |

|                                                                                                                                                                                                                                                        |
|--------------------------------------------------------------------------------------------------------------------------------------------------------------------------------------------------------------------------------------------------------|
| <b>Rear spoiler</b>                                                                                                                                                                                                                                    |
| integrated in the luggage compartment lid; extends electrically depending on vehicle speed; automatically extends at 130 <span> </span> km/h, retracts at 80 <span> </span> km/h; can also be controlled manually using a button in the centre console |

|                                                                           |
|---------------------------------------------------------------------------|
| <b>Model name/logo</b>                                                    |
| RS 7 model name on the radiator grille and on the luggage compartment lid |

|                        |
|------------------------|
| <b>Sill extensions</b> |
| painted in body colour |

|                       |
|-----------------------|
| <b>Engine cover</b>   |
| with carbon detailing |

| <b>Seats/seating comfort</b>                      |
|---------------------------------------------------|
| <b>4-way lumbar support for the front seats</b>   |
| electric, with horizontal and vertical adjustment |

|                                                                                                                                                                                                                                              |
|----------------------------------------------------------------------------------------------------------------------------------------------------------------------------------------------------------------------------------------------|
| <b>Front seats, electrically adjustable with memory function for the driver seat</b>                                                                                                                                                         |
| with electric adjustment of seat height, fore/aft position, seat and backrest angle; including electric 4-way lumbar support; 2 presets for the electrically adjustable driver seat, electric steering wheel adjustment and exterior mirrors |

|                                                                                                                                                                                                                                                                                                                             |
|-----------------------------------------------------------------------------------------------------------------------------------------------------------------------------------------------------------------------------------------------------------------------------------------------------------------------------|
| <b>RS sport seats in the rear</b>                                                                                                                                                                                                                                                                                           |
| 2 single seats in the rear with shaped side bolsters and integrated head restraints, visually matched to the front seats; rear seat backrest can be split-folded 40 <span> </span> : 60 or fully with remote backrest release in the luggage compartment; rear seat bench with integrated storage compartment in the centre |

|                                                                                                                                   |
|-----------------------------------------------------------------------------------------------------------------------------------|
| <b>RS sport seats in the rear including fold-out centre armrest</b>                                                               |
| equipment as for RS sport seats in the rear, additionally with fold-out centre armrest with storage compartment and 2 cup holders |

|                                                                                                                                                                                                                                                       |
|-------------------------------------------------------------------------------------------------------------------------------------------------------------------------------------------------------------------------------------------------------|
| <b>Rear seat system with 2 seats</b>                                                                                                                                                                                                                  |
| visually matched to the front seats; 2 L-shaped rear head restraints, height manually adjustable, rear seat backrest can be split-folded 40 <span> </span> : 60 or fully including fold-out centre armrest with storage compartment and 2 cup holders |

|                                                                                                                                                                                                                            |
|----------------------------------------------------------------------------------------------------------------------------------------------------------------------------------------------------------------------------|
| <b>Massage function, front</b>                                                                                                                                                                                             |
| massages the muscles using 10 pneumatic cushions; 5 different programs (Wave, Tapping, Stretch, Lumbar, Shoulder), each offering 5 levels of intensity; can be selected via multifunction switches on the seat and via MMI |

|                                                                                                                                                                                                                                                                                                                                                                                            |
|--------------------------------------------------------------------------------------------------------------------------------------------------------------------------------------------------------------------------------------------------------------------------------------------------------------------------------------------------------------------------------------------|
| <b>Seat ventilation, front</b>                                                                                                                                                                                                                                                                                                                                                             |
| active seat ventilation of the seat and backrest centre panels as well as the thigh support for the driver and front-passenger seats; the system ensures a pleasant seating climate even at high ambient temperatures; adjustable in 3 stages directly on the air conditioning control panel; if seat ventilation, front, is fitted, the leather on the front and rear seats is perforated |

|                                                                                                                                                                                                                       |
|-----------------------------------------------------------------------------------------------------------------------------------------------------------------------------------------------------------------------|
| <b>Seat heating, front</b>                                                                                                                                                                                            |
| heats seat and backrest centre panels as well as seat side bolsters; can be individually adjusted in 3 stages for driver and front-passenger side via a direct selection button on the air conditioning control panel |

|                                                                                             |
|---------------------------------------------------------------------------------------------|
| <b>Seat heating, front and rear</b>                                                         |
| functions as for seat heating, front, also for the rear seats, can be controlled separately |

|                                                                         |
|-------------------------------------------------------------------------|
| <b>Centre armrest, front</b>                                            |
| for driver and front passenger, with adjustable angle, fold-open design |

|                                                                                                                                                             |
|-------------------------------------------------------------------------------------------------------------------------------------------------------------|
| <b>ISOFIX child seat mounting for the rear seats</b>                                                                                                        |
| standard bracket for the practical fastening of child seats in accordance with ISO standards; compatible child seats can be obtained from your Audi partner |

|                                                                                                      |
|------------------------------------------------------------------------------------------------------|
| <b>ISOFIX child seat mounting for the front-passenger seat</b>                                       |
| with passenger airbag deactivation switch, includes separate electric child-proof lock on rear doors |

| <b>Steering wheels/selector levers/controls</b>                                                                                                                                                                                              |
|----------------------------------------------------------------------------------------------------------------------------------------------------------------------------------------------------------------------------------------------|
| <b>RS leather-covered multifunction sport steering wheel in 3-spoke design, flattened at the bottom</b>                                                                                                                                      |
| with shift paddles in aluminium look and RS 7 emblem, full-size airbag, covered in perforated leather with decorative stitching in rock grey; adjustable for height and reach; for operating the infotainment features fitted in the vehicle |

|                                                                                                                                                                                                                                              |
|----------------------------------------------------------------------------------------------------------------------------------------------------------------------------------------------------------------------------------------------|
| <b>RS leather-covered multifunction sport steering wheel in 3-spoke design</b>                                                                                                                                                               |
| with shift paddles in aluminium look and RS 7 emblem, full-size airbag, covered in perforated leather with decorative stitching in rock grey; adjustable for height and reach; for operating the infotainment features fitted in the vehicle |

|                                                                                                                                                                                               |
|-----------------------------------------------------------------------------------------------------------------------------------------------------------------------------------------------|
| <b>RS leather-covered multifunction sport steering wheel in 3-spoke design, heated</b>                                                                                                        |
| with shift paddles, full-size airbag, leather-covered; adjustable for height and reach; for operating the infotainment features fitted in the vehicle, steering-wheel rim additionally heated |

|                                                                                                                                                                                               |
|-----------------------------------------------------------------------------------------------------------------------------------------------------------------------------------------------|
| <b>Leather-covered multifunction sport steering wheel in 3-spoke design, heated</b>                                                                                                           |
| with shift paddles, full-size airbag, leather-covered; adjustable for height and reach; for operating the infotainment features fitted in the vehicle, steering-wheel rim additionally heated |

|                                                                        |
|------------------------------------------------------------------------|
| <b>Steering wheel adjustment, electric</b>                             |
| adjustable in height and reach, with automatic entry and exit function |

|                                                                                                                                                                                                                                                                 |
|-----------------------------------------------------------------------------------------------------------------------------------------------------------------------------------------------------------------------------------------------------------------|
| <b>RS selector lever knob in perforated leather</b>                                                                                                                                                                                                             |
| with RS emblem and decorative ring in aluminium look; selector lever gaiter in leather with decorative stitching in rock grey; in conjunction with leather-covered multifunction sport steering wheel in 3-spoke design, heated, selector lever knob in leather |

|                                                                                                                                                                                                             |
|-------------------------------------------------------------------------------------------------------------------------------------------------------------------------------------------------------------|
| <b>Audi exclusive leather steering-wheel rim</b>                                                                                                                                                            |
| leather for the steering-wheel rim available in all Audi exclusive colours; individual choice of colour for decorative stitching in various Audi exclusive colours with specific Audi exclusive seam detail |

|                                                                                                                                                                                                                                                                                             |
|---------------------------------------------------------------------------------------------------------------------------------------------------------------------------------------------------------------------------------------------------------------------------------------------|
| <b>Audi exclusive leather controls</b>                                                                                                                                                                                                                                                      |
| leather for the steering wheel rim, selector lever knob and gaiter available in all Audi exclusive colours; individual choice of colour for decorative stitching in various Audi exclusive colours; decorative stitching on the steering wheel rim with specific Audi exclusive seam detail |

|                                                                                                                                                                                                                                                            |
|------------------------------------------------------------------------------------------------------------------------------------------------------------------------------------------------------------------------------------------------------------|
| <b>Audi exclusive controls in black suede</b>                                                                                                                                                                                                              |
| leather for the steering wheel rim and selector lever knob in black suede; individual choice of colour for decorative stitching in various Audi exclusive colours; decorative stitching on the steering wheel rim with specific Audi exclusive seam detail |

| <b>Climate control</b> |
|------------------------|
|------------------------|

|                                                                                                                                                                                                                                                                                                                                                                                                                                                                                                                                                                                                                                                                                                                                                                                                                                                                                                                                                                                                                                                                                                             |
|-------------------------------------------------------------------------------------------------------------------------------------------------------------------------------------------------------------------------------------------------------------------------------------------------------------------------------------------------------------------------------------------------------------------------------------------------------------------------------------------------------------------------------------------------------------------------------------------------------------------------------------------------------------------------------------------------------------------------------------------------------------------------------------------------------------------------------------------------------------------------------------------------------------------------------------------------------------------------------------------------------------------------------------------------------------------------------------------------------------|
| <b>4-zone deluxe automatic air conditioning</b>                                                                                                                                                                                                                                                                                                                                                                                                                                                                                                                                                                                                                                                                                                                                                                                                                                                                                                                                                                                                                                                             |
| <ul style="list-style-type: none"><li>With indirect ventilation and sunlight-dependent control</li> <li>Electronically regulates the air temperature, flow rate and distribution</li> <li>Humidity sensor</li> <li>Combined/fine particulate filter</li> <li>Automatic recirculation mode by means of air quality sensor</li> <li>Use of residual heat</li> <li>Separate regulation of footwell temperature</li> <li>Ventilated glove compartment</li> <li>Front air conditioning control panel featuring digital display</li> <li>Separate temperature control for driver and front-passenger sides</li> <li>Ventilation in the rear via the centre console</li> <li>Air vents in the B pillars</li> <li>Additional air conditioning control panel with digital display for climate control in the rear with separately adjustable temperature and blower settings and air distribution for the right and left-hand sides (rear functions can also be set from the front air conditioning control panel)</li> <li>Choice of 3 climates: gentle, medium and intensive</li> <li>Key-coded settings</li></ul> |

| <b>Luggage securing and storage systems</b> |
|---------------------------------------------|
|---------------------------------------------|

|                                                                                                                                                                                                                                                                                      |
|--------------------------------------------------------------------------------------------------------------------------------------------------------------------------------------------------------------------------------------------------------------------------------------|
| <b>Storage compartments</b>                                                                                                                                                                                                                                                          |
| storage compartment in the front and rear door trims including bottle holder, storage net on the backs of the front-seat backrests, storage compartments under the front seats (not in conjunction with comfort seats, front, with memory function) as well as in the centre console |

|                                                                                   |
|-----------------------------------------------------------------------------------|
| <b>Glove compartment</b>                                                          |
| on the front-passenger side, lockable, with light and holder for writing utensils |

|                                                                                                                                |
|--------------------------------------------------------------------------------------------------------------------------------|
| <b>Storage package</b>                                                                                                         |
| luggage compartment net for securing to the lashing points on the luggage compartment floor, additional 12V socket in the rear |

|                                       |
|---------------------------------------|
| <b>Cup holders</b>                    |
| 2, integrated into the centre console |

|                                                                                                                                                                                        |
|----------------------------------------------------------------------------------------------------------------------------------------------------------------------------------------|
| <b>Luggage compartment</b>                                                                                                                                                             |
| large-volume with large through-loading width; includes side net on the right-hand side; 4 lashing points on the luggage compartment floor; with 12V socket; luggage compartment cover |

|                                                             |
|-------------------------------------------------------------|
| <b>Bag hooks</b>                                            |
| on the left and right-hand sides of the luggage compartment |

|                                                                                                                                                    |
|----------------------------------------------------------------------------------------------------------------------------------------------------|
| <b>Reversible mat</b>                                                                                                                              |
| for luggage compartment, velour on one side, rubber on the other, folds out to cover the luggage compartment, even with the rear seats folded down |

|                                                  |
|--------------------------------------------------|
| <b>Through-loading facility</b>                  |
| for the practical transportation of long objects |

|                                                                                                               |
|---------------------------------------------------------------------------------------------------------------|
| <b>Through-loading facility with removable ski/snowboard bag</b>                                              |
| secured by a strap, for practical transportation of long objects, e. g. up to 4 pairs of skis or 2 snowboards |

| <b>Further interior equipment</b>            |
|----------------------------------------------|
| <b>Pedals and footrest in aluminium look</b> |

|                                   |
|-----------------------------------|
| <b>Floor mats, front and rear</b> |
| in velour, black                  |

|                                                                                             |
|---------------------------------------------------------------------------------------------|
| <b>Audi exclusive floor mats with RS 7 logo</b>                                             |
| in black, with embroidery of the front floor mats; piping and decorative stitching in black |

|                                                                                                                                                           |
|-----------------------------------------------------------------------------------------------------------------------------------------------------------|
| <b>Audi exclusive floor mats with RS 7 logo and coloured leather piping</b>                                                                               |
| in black, with embroidery of the front floor mats. Individual choice of colours for piping and decorative stitching from the Audi exclusive colour range. |

|                                                                                             |
|---------------------------------------------------------------------------------------------|
| <b>Audi exclusive floor mats</b>                                                            |
| individual choice of colours for floor mats and piping from the Audi exclusive colour range |

|                                                                                                     |
|-----------------------------------------------------------------------------------------------------|
| <b>Audi exclusive carpet and floor mats</b>                                                         |
| individual choice of colours for carpet, floor mats and piping from the Audi exclusive colour range |

|                                                 |
|-------------------------------------------------|
| <b>Door sill trims</b>                          |
| with aluminium insert and illuminated RS 7 logo |

|                                                                                                                                                                                                                                    |
|------------------------------------------------------------------------------------------------------------------------------------------------------------------------------------------------------------------------------------|
| <b>Aluminium look in the interior</b>                                                                                                                                                                                              |
| on the light switch, window controls switch and mirror adjustment switch, 4-zone deluxe automatic air conditioning, MMI rotary/push-button control including quattro-logic buttons, air vents and around the selector lever gaiter |

|                                        |
|----------------------------------------|
| <b>Surround for instrument cluster</b> |
| in piano finish look, black            |

|                                                                     |
|---------------------------------------------------------------------|
| <b>Headlining in cloth</b>                                          |
| in black or lunar silver, depending on the interior colour selected |

|                                                                                                               |
|---------------------------------------------------------------------------------------------------------------|
| <b>Headlining in Alcantara, black</b>                                                                         |
| headlining, upper pillar trim, parcel shelf and sun visors in Alcantara, black, decorative stitching in black |

|                                                                                                                                                                            |
|----------------------------------------------------------------------------------------------------------------------------------------------------------------------------|
| <b>Headlining in Alcantara, black with Audi exclusive coloured decorative stitching</b>                                                                                    |
| headlining, upper pillar trim, parcel shelf and sun visors in Alcantara, black. Individual choice of colour for decorative stitching from the Audi exclusive colour range. |

|                                      |
|--------------------------------------|
| <b>Cigarette lighter and ashtray</b> |
| illuminated, front and rear          |

|                                                                                                  |
|--------------------------------------------------------------------------------------------------|
| <b>Non-smoker version</b>                                                                        |
| a storage compartment at the front and a 12V socket at the rear instead of the cigarette lighter |

| <b>MMI® and navigation systems</b> |
|------------------------------------|
|------------------------------------|

|                                                                                                                                                                                                                                                                                                                                                                                                                                                                                                                                                                                                                                                                                                                                                                                                                                                                                                                                                                                                                                                                                                                                                                       |
|-----------------------------------------------------------------------------------------------------------------------------------------------------------------------------------------------------------------------------------------------------------------------------------------------------------------------------------------------------------------------------------------------------------------------------------------------------------------------------------------------------------------------------------------------------------------------------------------------------------------------------------------------------------------------------------------------------------------------------------------------------------------------------------------------------------------------------------------------------------------------------------------------------------------------------------------------------------------------------------------------------------------------------------------------------------------------------------------------------------------------------------------------------------------------|
| <b>MMI® navigation plus with MMI touch</b>                                                                                                                                                                                                                                                                                                                                                                                                                                                                                                                                                                                                                                                                                                                                                                                                                                                                                                                                                                                                                                                                                                                            |
| <ul style="list-style-type: none"><li>With navigation data (hard drive)<sup>1</sup></li> <li>High-resolution 8-inch colour display with high-quality map display and topographical map colouring, display of lots of sightseeing information and city models in 3D; choice of 3 alternative routes, scrolling along the route and manoeuvring within the map</li> <li>Split-screen route information (manoeuvring points, points of interest on motorways, TMCpro on route), detailed junction map, motorway exits and lane recommendations also in driver information system, dynamic route guidance with TMCpro (where available)</li> <li>Vehicle support based on navigation data and speed limit display</li> <li>Voice control system (whole-word entry of address in one sentence)</li> <li>Spoken TMCpro reports</li> <li>Driver information system with 7-inch colour display</li> <li>MMI radio plus</li> <li>Hard drive for storing music (20 GB)</li> <li>DVD drive (MP3, WMA, AAC and MPEG-4 compatible)</li> <li>2 SDHC card readers (for up to 32 GB)</li> <li>Bluetooth interface with Bluetooth audio streaming</li> <li>Audi sound system</li></ul> |

|                                                                                                                                                                                                                                                                     |
|---------------------------------------------------------------------------------------------------------------------------------------------------------------------------------------------------------------------------------------------------------------------|
| The use of services supported by Audi connect, such as navigation with Google Earth™ map service <sup>2</sup> and Google Street View™ <sup>2</sup> , weather, news and traffic information is possible in combination with Audi connect including car phone online. |
|---------------------------------------------------------------------------------------------------------------------------------------------------------------------------------------------------------------------------------------------------------------------|

|                                                                                                                                                                                                                                                                                                                                                                                                                                                                                                               |
|---------------------------------------------------------------------------------------------------------------------------------------------------------------------------------------------------------------------------------------------------------------------------------------------------------------------------------------------------------------------------------------------------------------------------------------------------------------------------------------------------------------|
| <b>MMI® touch</b>                                                                                                                                                                                                                                                                                                                                                                                                                                                                                             |
| part of the MMI navigation plus; touch-sensitive control panel for intuitive operation of the MMI; letters and numbers can be entered without drivers taking their eyes off the road; contextual entry of letters and numbers via handwriting recognition for navigation destinations, selection from address book or entry of telephone numbers with acoustic acknowledgement, simple movement of navigation map and selection of points of interest, retrieval of 6 freely assignable radio station presets |

<sup>[1]</sup> The model-specific standard and optional equipment can be found in the index from page 58 onwards

<sup>[2]</sup> Navigation data is not available for all countries and regions. For more information, please contact your local Audi partner.  ^2 Google and the Google logo are registered trademarks of Google Inc

**Driver information system with 7-inch colour display** high-resolution TFT colour display directly in the driver's field of view; displays information from the MMI system, the infotainment systems and the driver assistance systems; display for the trip computer with short and long-term memory, digital speedometer, gear display, outside temperature, plus door and luggage compartment lid check; RS menu with shift light, charge pressure and oil temperature display as well as lap timer; can be operated via a leather-covered multifunction sport steering wheel; including attention assist

#### Attention assist

part of the driver information system; the attention assist analyses driving behaviour using a range of sensors. Steering movements and pedal actuation, for example, are recorded and compared with the individual driving patterns of the respective driver. If the evaluation indicates that the driver's attention seems to be lapsing, the system recommends a break by means of a display in the driver information system and an acoustic signal. The system is active between 65 km/h and 200 km/h and can be deactivated.

| Radio and TV systems |
|----------------------|
|----------------------|

#### Digital Audio Broadcasting

receives programmes from digitally broadcast radio stations in addition to the range of analogue stations, with better sound quality according to DAB standard, including DAB+ and DMB audio. Display of additional information accompanying the programme (e.g. artist, title, cover) in the form of a slide show and other programme-independent data services (e.g. weather, traffic, news). A second DAB tuner permanently searches for alternative reception frequencies of the set station, and the station list is updated at the same time. Please note: reception depends on local digital network availability; contents and scope of the additional information depend on provision by the respective radio station.

#### Digital TV reception

reception of digitally broadcast (DVB-T), uncoded television stations (MPEG-2 or MPEG-4 standard), supports DVB-T audio stations, teletext and Electronic Programme Guide (EPG). External AV-IN connection via adapter cable (available through Audi Genuine Accessories). Please note: TV reception depends on digital network availability; no picture possible when the vehicle is moving

| Audi sound system |
|-------------------|
|-------------------|

10 speakers including centre speaker in the dashboard and subwoofer in the spare wheel well, 6-channel amplifier with a total output of 180 watts

| BOSE surround sound |
|---------------------|
|---------------------|

surround sound reproduction with 14 loudspeakers including a centre speaker in the dashboard and subwoofer in the spare wheel well, 12-channel amplifier with total output of over 600 watts; powerful and accurate bass reproduction, lifelike sound with natural tone and a feeling of space for an outstanding sound experience; sound system matched to the interior acoustics of the vehicle extremely well; AudioPilot® for noise-dependent volume adjustment; 5.1 surround sound reproduction possible.

| Bang & Olufsen Advanced Sound System |
|--------------------------------------|
|--------------------------------------|

surround sound reproduction with 15 loudspeakers including subwoofer and centre speaker, each with its own amplifier channel; polished loudspeaker covers in aluminium; automatically extending acoustic lenses for excellent sound performance and perspective from every seat; 10-channel DSP all-digital amplifier; all-digital highly efficient 5-channel ICE Power amplifier for woofers and subwoofer; with total output of over 1,200 watts; 5.1 surround sound reproduction possible; privacy function: encapsulated loudspeaker casings minimise escape of sound to the outside of the vehicle and provide privacy, for example when making telephone calls in hands-free mode; a precisely defined loudspeaker effect has also been achieved; noise-dependent volume adjustment

#### CD changer

in the glove compartment, for 6 CDs (MP3 and WMA capable), shock-resistant, each CD can be loaded and changed individually. Music files with digital rights management (DRM) cannot be played.

| DVD/CD changer |
|----------------|
|----------------|

in glove compartment, for 6 DVDs or CDs, supports e.g. audio CDs, video DVDs and MP3, WMA, AAC, MPEG-4 and playlists; shock-resistant; DVDs and CDs can be changed individually; supports up to 4,000 tracks per medium. Music files with digital rights management (DRM) cannot be played.

| Audi music interface |
|----------------------|
|----------------------|

for connecting portable media players, such as Apple iPod generation 4 and higher, Apple iPhone (music functionality), USB storage media and MP3 players. The Audi music interface is housed in the centre console; it is operated via the MMI or a leather-covered multifunction sport steering wheel.

Note: can only be used in conjunction with a special adapter cable (available from Audi Genuine Accessories). Please contact your Audi partner or visit www.audi.com/mp3 for information on compatibility. If the Audi music interface is ordered the separate AUX-IN connection is omitted.

| Adapter cable set for Audi music interface |
|--------------------------------------------|
|--------------------------------------------|

consisting of 2 connection cables to connect iPod/iPhone or data storage devices/media players with USB port (type A); other adapter cables available from Audi Genuine Accessories; please contact your Audi partner or visit www.audi.com/mp3 for information on compatibility.

| Adapter cable set plus for Audi music interface |
|-------------------------------------------------|
|-------------------------------------------------|

in addition to the adapter cable set for Audi music interface: support for the representation of cover arts, video functions, etc., depending on the device used; please contact your Audi partner or visit www.audi.com/mp3 for information on compatibility.

#### Preparation for Rear Seat Entertainment

includes pre-installed wiring and mounts for the holders in the driver and front-passenger seat backrests. The appropriate Audi Entertainment mobile (9-inch screen with integrated DVD player) and the holder are available as a plug-and-play unit from Audi Genuine Accessories.

| Telephone and communication |
|-----------------------------|
|-----------------------------|

| Bluetooth interface |
|---------------------|
|---------------------|

Bluetooth-capable mobile phones can be connected to the vehicle via the interface; hands-free calls are possible in the vehicle via the microphone; including Bluetooth audio streaming (depending on mobile phone compatibility). Please contact your Audi partner or visit www.audi.com/bluetooth for information on compatible mobile phones.

| Preparation for mobile phone (Bluetooth) |
|------------------------------------------|
|------------------------------------------|

comprises a hands-free facility and voice control for telephone functions as well as a preparation for optional mobile-specific charger in the front centre console; includes connection to the vehicle aerial, reducing SAR radiation inside the vehicle and improving reception quality; operated using the MMI navigation plus with MMI touch or a leather-covered multifunction sport steering wheel. Please contact your Audi partner or visit www.audi.com/bluetooth for adapters and information on compatible mobile phones.

| Bluetooth car phone |
|---------------------|
|---------------------|

Your Bluetooth-capable mobile phone can be conveniently connected to the vehicle's internal UMTS module (provided that your mobile supports SIM Access Profile); additional SIM card reader located in the surround of the MMI navigation plus with MMI touch; transfer of phone book entries to the vehicle and management of call lists; operated using the MMI navigation system or a leather-covered multifunction sport steering wheel; please contact your Audi partner or visit www.audi.com/bluetooth for information on compatible mobile phones.

#### Audi connect<sup>1</sup> including car phone

convenient connection of your vehicle to the internet. Use of the services supported by Audi connect is possible only with the **MMI navigation plus with MMI touch** and with the data module integrated in Audi connect including car phone. You also require a SIM card with data option – with car phone a SIM card with phone and data option or a Bluetooth-capable smartphone with remote SIM Access Profile (rSAP). There is a reader for your SIM card in the surround of the MMI navigation plus with MMI touch.

The following **services** supported by **Audi connect** are available in your model:

| Mobility & navigation |
|-----------------------|
|-----------------------|

- Point-of-interest (POI) search with voice control
- Traffic information online
- Navigation with Google Earth™ map service<sup>2</sup> and Google Street View™ <sup>2</sup>
- Destination entry via myAudi or Google Maps™ <sup>2</sup>
- Fuel prices
- Parking information
- Country information

| Communication |
|---------------|
|---------------|

- Wi-Fi hotspot

| Infotainment |
|--------------|
|--------------|

- Weather
- Audi music stream
- News online
- City events
- Travel information

The services are available only with an existing or separate mobile phone contract and only within the range of the respective mobile phone network. Additional costs may be incurred when receiving data packets from the internet, depending on the terms of your mobile phone contract, particularly when used abroad. Because of the high data volumes involved, a data flat rate is strongly recommended

The availability of the services supported by Audi connect varies from country to country. The services are provided for at least one year from vehicle delivery. The traffic information online service requires initial activation in the vehicle. From that point onwards, this service is subject to a 36-month usage limit (in as far as activation takes place within 6 months of vehicle delivery; otherwise corresponding shortening of the usage rights). Your Audi partner will be happy to inform you about how to extend the service and the costs this incurs.

Please visit www.audi.com/connect or contact your Audi partner for more detailed information about Audi connect; contact your mobile services provider for information about contract conditions.

| Handset, front, for the car phone |
|-----------------------------------|
|-----------------------------------|

wireless handset with colour display and integrated SIM card reader, for making private phone calls; easy writing of text messages thanks to automatic word recognition; handset is stored in the front centre armrest

| Assistance systems |
|--------------------|
|--------------------|

| Audi pre sense basic |
|----------------------|
|----------------------|

Networking the different vehicle systems enables driving situations to be categorised and, where necessary, actions to be implemented for preventive occupant protection. These include: belt tightening, activating the hazard warning system and closing the windows as well as the slide-and-tilt glass sunroof (can be ordered as an option).

| adaptive cruise control with Stop&Go function incl. Audi pre sense front |
|--------------------------------------------------------------------------|
|--------------------------------------------------------------------------|

automatic distance control (control range 0–250 km/h); working within system limits, it uses 2 radar sensors and a camera to detect vehicles ahead and maintains the distance by automatic braking and accelerating; independent braking to a stop, automated restart at driver's request; 4 distance levels and 3 driving modes (comfort, auto and dynamic) can be selected individually. The use of Audi connect services is possible: the navigation system stores route data such as the sweep of bends and corners or road classifications allowing comfortable distance control, for instance when following traffic on winding roads. In addition to the functions of Audi pre sense basic, Audi pre sense front implements preventive occupant protection measures when threatened with an imminent frontal collision; includes Audi braking guard with driver warning through an extended brake assist feature and with preventive occupant protection. Working within system limits, Audi pre sense front utilises the front sensors of adaptive cruise control with Stop&Go function to carry out its detection tasks; extended by the function of maximum deceleration: this is initiated at speeds below 30 km/h if there is a danger of collision with a stationary or moving vehicle in order to reduce the severity of the collision or to avoid this collision if possible.

#### Audi active lane assist

lane compliance assistant; within system limits comfortably assists the driver with keeping in lane (operating range 60–250 km/h); if the system is activated and ready and the driver did not indicate, the Audi active lane assist will guide the vehicle within recognised lane boundary lines by means of gentle, corrective steering intervention; the driver can choose whether he would like to be supported continuously or just shortly before crossing the road marking (choice of earlier or later steering time); additional steering wheel vibration can be set if the driver wishes; additional display in the head-up display (can be ordered as an option)

| Audi side assist including Audi pre sense rear |
|------------------------------------------------|
|------------------------------------------------|

lane change assistant, within system limits assists the driver when changing lanes (operating range 30–250 km/h). Displays are incorporated into both exterior mirrors. Audi side assist uses 2 radar sensors to measure the vehicle's distance from other vehicles it has detected as well as the speed difference between them. If Audi side assist classifies the speed difference and distance as being critical in the event of a lane change, a display will appear in the respective exterior mirror. In addition to the functions of Audi pre sense basic, Audi pre sense rear uses the rear sensors of Audi side assist, while working within the system limits, to detect a possible rear-end collision.

| Assistance package including Audi pre sense plus |
|--------------------------------------------------|
|--------------------------------------------------|

The assistance package contains the functions of the following assistance systems:

- adaptive cruise control with Stop&Go function
- Audi active lane assist
- Audi side assist
- Audi pre sense front
- Audi pre sense rear

A maximum deceleration function is added to the features of Audi pre sense basic, Audi pre sense front and Audi pre sense rear to form Audi pre sense plus. In addition to the functions of Audi pre sense front, Audi pre sense plus activates the Audi braking guard in certain situations in which a collision is unavoidable and initiates maximum deceleration to reduce the impact speed by up to 40 km/h.

<sup>[1]</sup> The model-specific standard and optional equipment can be found in the index from page 58 onwards

<sup>[2]</sup> For information on when the Audi connect services will be available, please contact your Audi partner ^2Google and the Google logo are registered trademarks of Google Inc

**Night vision assistant with highlighting of detected pedestrians** with integrated thermal imaging camera; when driving at night, this system extends the driver’s range of visibility beyond the light provided by the dipped beam; records thermal images; an image processing algorithm then evaluates the camera’s data and highlights any persons it has detected in yellow in the driver information system’s colour display; the highlighting changes to red and a warning tone is emitted if the system, by analysing the movement and position of the person it has detected, considers that there is a possible risk. In combination with one of the following light systems, the person will additionally be illuminated by a headlight 3 times in quick succession (marking light): xenon plus in conjunction with high-beam assist, adaptive light including variable headlight range control or LED headlights. Additional warning symbol in the head-up display (optionally available); image quality is affected in poor ambient conditions.

| <p><b>Head-up display</b> projects as required information relevant to the driver from the assistance systems, the navigation or the RS menu in the driver information system as well as warning symbols onto the windscreen in the driver’s direct field of vision; height adjustable; provides a multicoloured display with good contrast and minimal distraction from the road</p> |
|---------------------------------------------------------------------------------------------------------------------------------------------------------------------------------------------------------------------------------------------------------------------------------------------------------------------------------------------------------------------------------------|

**Cruise control** at speeds from around 30 km/h up to 250 km/h, the system keeps the set speed constant, provided that engine power and engine braking effect permit it; operated via separate steering column stalk, set speed displayed in driver information system

| <p><b>Camera-based speed limit display</b> camera-based recognition and display of speed limits, including temporary speed limit displays (e.g. above motorways). Additionally, working within system limits, there is an evaluation of the particular situation in wet conditions, with speed limits displayed depending on the time of day, in roadworks and when using a trailer. If a sign has not been recognised by the camera, thanks to Audi connect the speed limit taken from the navigation data (where available) can be displayed. Additional display in the head-up display (can be ordered as an option)</p> |
|-----------------------------------------------------------------------------------------------------------------------------------------------------------------------------------------------------------------------------------------------------------------------------------------------------------------------------------------------------------------------------------------------------------------------------------------------------------------------------------------------------------------------------------------------------------------------------------------------------------------------------|

**Camera-based speed limit display** camera-based recognition and display of speed limits, including temporary speed limit displays (e.g. above motorways). Additionally, working within system limits, there is an evaluation of the particular situation in wet conditions, with speed limits displayed depending on the time of day, in roadworks and when using a trailer. If a sign has not been recognised by the camera, thanks to Audi connect the speed limit taken from the navigation data (where available) can be displayed. Additional display in the head-up display (can be ordered as an option)

The model-specific standard and optional equipment can be found in the index from page 58 onwards.

**Hold assist** holds the vehicle stationary for unlimited periods after stopping on normal uphill and downhill gradients. The system is activated by push-button and allows the driver to pull away smoothly.

| <p><b>Parking system plus</b> acoustic and visual parking system for the front and rear shown on the MMI display; measurement is by ultrasonic sensors concealed in the bumpers</p> |
|-------------------------------------------------------------------------------------------------------------------------------------------------------------------------------------|

**Park assist with display of surroundings** searches for suitable parking spaces along the road by means of ultrasonic sensors, calculates the ideal parking path for perpendicular parking spaces, and for parallel parking spaces the ideal path for parking and leaving; completes the steering manoeuvre almost automatically. Parking is now even possible in smaller parking spaces and curve areas; parking in several moves is supported. Steering is done by the vehicle, while the driver only needs to accelerate and apply the brakes. The display of surroundings tracks obstacles at the side of the vehicle and alerts the driver to them, depending on the steering angle, thereby helping to manoeuvre into and out of parking spaces with ease.

| <p><b>Rearview camera</b> image of area behind the vehicle shown on the MMI display, with dynamic display elements showing the calculated path (depending on steering angle) including auxiliary lines and guidelines and identification of the point at which to apply opposite lock when parallel parking, rearview camera integrated discreetly in the handle strip of the luggage compartment lid</p> |
|-----------------------------------------------------------------------------------------------------------------------------------------------------------------------------------------------------------------------------------------------------------------------------------------------------------------------------------------------------------------------------------------------------------|

**Front and rearview cameras** image of area in front of and behind the vehicle shown on the MMI display, with dynamic display elements showing the calculated path (depending on steering angle) including auxiliary lines and guidelines and identification of the point at which to apply opposite lock when parallel parking; reversing camera integrated discreetly in the handle strip of the luggage compartment lid; additional display modes for front to the left/right side and rear to the left/right side for safe driving out of tight parking slots, yard entrances or in multi-storey car parks

| <p><b>Suspensions/brakes</b></p> <p><b>Audi drive select</b> changes vehicle characteristics by adapting power steering assistance, accelerator and gearshift characteristics, the RS adaptive air suspension, as well as exhaust flap control; modes available: comfort, auto, dynamic and individual. The system also influences other optional equipment.</p> |
|------------------------------------------------------------------------------------------------------------------------------------------------------------------------------------------------------------------------------------------------------------------------------------------------------------------------------------------------------------------|

**Electromechanical power steering** maintenance-free rack & pinion steering with speed-dependent power assistance; precise steering feel at high speeds, excellent assistance when parking; active countersteering provides steering assistance to the driver for enhanced vehicle stability

| <p><b>Dynamic steering</b> When changing lanes, parking and cornering, this system improves comfort and handling by dynamically regulating steering according to the driving situation. In addition to adaptation of the steering effort (as with the electromechanical power steering), the steering angle is also adapted (steering ratio). The system is also supported further by vehicle stabilisation through ESC.</p> |
|------------------------------------------------------------------------------------------------------------------------------------------------------------------------------------------------------------------------------------------------------------------------------------------------------------------------------------------------------------------------------------------------------------------------------|

**RS adaptive air suspension** electronically controlled air suspension with infinitely variable adaptive damping system on all 4 wheels, with RS 7-specific tuning, automatically controls vehicle level and damping; 4 modes (auto, comfort, dynamic, lift) can be selected via MMI; including ride height control

**RS sport suspension plus with Dynamic Ride Control (DRC)** adjustable in 3 stages; single-tube gas-filled shock absorbers with variable damping characteristics and coil springs; control range of Dynamic Ride Control (DRC) can be selected in 3 stages via Audi drive select: comfort, auto, dynamic

| <p><b>RS brake system</b> 19-inch diagonally-split high-performance brake system, Antilock Brake System (ABS) and Electronic Brake Force Distribution (EBD), Electronic Stabilisation Control (ESC) with brake assist; aluminium tandem brake booster, wave brake discs ventilated at front and rear, perforated and with floating mounting</p> |
|-------------------------------------------------------------------------------------------------------------------------------------------------------------------------------------------------------------------------------------------------------------------------------------------------------------------------------------------------|

**Brake callipers** painted high-gloss black, front callipers feature RS emblem; optionally painted high-gloss red\*

| <p><b>Ceramic brake</b> 20-inch high-performance brake system with carbon-fibre reinforced ceramic brake discs front and rear, specially developed cooling channels for the ventilated and perforated brake discs; brake callipers painted in high-gloss anthracite, with “Audi ceramic logo” at the front. Please consult your Audi partner or national Audi website to find out more about the special features of the ceramic brake.</p> |
|---------------------------------------------------------------------------------------------------------------------------------------------------------------------------------------------------------------------------------------------------------------------------------------------------------------------------------------------------------------------------------------------------------------------------------------------|

**Electromechanical parking brake** includes parking brake function when stationary, drive-off assistance function through automatic release when driving away and emergency braking function whilst driving by means of action on all 4 wheels

| <p><b>Technology/safety</b></p> <p><b>Body, galvanised</b> lightweight aluminium hybrid construction; fully-galvanised in areas at risk from corrosion, unitary construction, welded to the floor pan, front and rear areas feature defined crumple zones. (12 year guarantee against rust perforation)</p> |
|-------------------------------------------------------------------------------------------------------------------------------------------------------------------------------------------------------------------------------------------------------------------------------------------------------------|

| <p><b>Side impact protection</b> front and rear aluminium impact protection bars integrated into the doors</p> |
|----------------------------------------------------------------------------------------------------------------|

| <p><b>Airbags</b> full-size airbags for driver and front passenger; in conjunction with ISOFIX child seat mounting for the front-passenger seat including deactivation switch for front-passenger airbag</p> |
|--------------------------------------------------------------------------------------------------------------------------------------------------------------------------------------------------------------|

| <p><b>Side airbags, front and head airbag system</b> front side airbags integrated into the seat backrests; with additional head airbag system: unfolds over the entire length of the side windows to protect front and rear passengers in the event of a side impact</p> |
|---------------------------------------------------------------------------------------------------------------------------------------------------------------------------------------------------------------------------------------------------------------------------|

**Side airbags, rear** to supplement the side airbags, front and head airbag system

| <p><b>Child-proof lock</b> electric child-proof lock on the rear doors, operated via the child-proof lock buttons in the driver’s door armrest; additional electric child-proof lock for the rear windows</p> |
|---------------------------------------------------------------------------------------------------------------------------------------------------------------------------------------------------------------|

**Integrated head restraint system** In the case of a rear-end collision, the shape of the front seat better restrains the upper body and provides more support for the head than conventional systems. This increases the level of protection and reduces the risk of a whiplash injury.

**Instrument cluster** with black dials, red needles and white scales, RS 7 logo in the rev counter; automatic ready-check; with adjustable lighting, electronic speedometer with odometer and trip odometer, rev counter, clock, coolant temperature display and fuel gauge

**Safety steering column** supplements the protection offered by the seat belts and airbags

**Battery energy management** controls the supply of electric power to the vehicle whilst driving and when parked

| <p><b>Seat belts</b> 3-point inertia reel seat belts; reversible seat belt tensioners, adaptive belt force limiters and belt height adjustment/belt buckle status query at front; seat belt reminder for driver and front-passenger seats with acoustic and visual warning signal</p> |
|---------------------------------------------------------------------------------------------------------------------------------------------------------------------------------------------------------------------------------------------------------------------------------------|

**Audi exclusive seat belts** individual choice of colour for seat belt from the Audi exclusive colour range

**Warning triangle** with bracket on the inside of the luggage compartment lid

**First-aid kit** in the right-hand side trim of the luggage compartment; for RS sport seats including fold-out centre armrest and for rear seat system with 2 seats, in storage compartment in rear centre armrest

**Fuel tank** with an increased tank volume of 75 l

**Antilock Brake System (ABS)** with Electronic Brake Force Distribution (EBD) and hydraulic brake assist

**Anti-Slip Regulation (ASR)** for good traction and lateral stability, reduces spinning of the drive wheels

**Electronic Differential Lock (EDL)** On surfaces with varying levels of grip, this start-off assistant automatically brakes the drive wheels on surfaces that are too slippery, thereby ensuring smooth, powerful progress.

**Electronic Stabilisation Control (ESC)** with sport mode, can be deactivated in 2 stages; networks the ABS, EBD, ASR and EDL with its own sensors and compares the driving data with reference data; provides better stability through targeted braking of individual wheels and intervention in the engine management system

**tiptronic** 8-speed automatic transmission with Dynamic Shift Program (DSP) and sport program; option of manual control via shift paddles on the leather-covered multifunction sport steering wheel or by nudging the selector lever

**quattro®** permanent all-wheel drive with asymmetric/dynamic torque distribution, self-locking centre differential and wheel-selective torque distribution; distributes the drive forces depending on the driving situation to each individual wheel for precisely controlled handling

**quattro® with sport differential** The electronically controlled sport differential distributes variable amounts of drive force to each rear wheel and ensures outstanding acceleration performance in corners and stabilises the vehicle’s response to load change. It also improves direct steering characteristics and provides more agile handling due to the lower steering effort required.

**Electronic regulation of the top speed at 280 km/h**

**Recuperation** Increasing the generator voltage converts kinetic energy into usable electric power when the vehicle is coasting or braking. This recuperated (brake) energy is then used to assist the generator during subsequent acceleration, saving up to 3% fuel.

**Start-stop system** helps to reduce fuel consumption and CO<sub>2</sub> emissions by switching off the engine in stationary phases, e.g. at traffic lights. The start process is initiated as soon as the foot brake is released when moving off again. Can be deactivated via a button at any time.

| <p><b>Audi Extended Warranty</b></p> <p><b>Audi Extended Warranty</b> can only be ordered directly and on purchase of a new car; is a consistent continuation of the manufacturer’s guarantee so that you are protected against risk and can control servicing costs beyond the first 2 years. There is a total of 9 lifetime/total mileage combinations to choose from:</p> |
|------------------------------------------------------------------------------------------------------------------------------------------------------------------------------------------------------------------------------------------------------------------------------------------------------------------------------------------------------------------------------|

Additional 1 year Audi Extended Warranty, maximum total mileage 30,000 km

Additional 1 year Audi Extended Warranty, maximum total mileage 60,000 km

Additional 1 year Audi Extended Warranty, maximum total mileage 90,000 km

Additional 2 years Audi Extended Warranty, maximum total mileage 40,000 km

Additional 2 years Audi Extended Warranty, maximum total mileage 80,000 km

Additional 2 years Audi Extended Warranty, maximum total mileage 120,000 km

Additional 3 years Audi Extended Warranty, maximum total mileage 50,000 km

Additional 3 years Audi Extended Warranty, maximum total mileage 100,000 km

Additional 3 years Audi Extended Warranty, maximum total mileage 150,000 km

<sup>[1]</sup> \*For information on when this feature will be available, please contact your Audi partner

| Model                                          | RS 7 Sportback                                                |      |
|------------------------------------------------|---------------------------------------------------------------|------|
| Engine type                                    | V8 petrol engine with direct fuel injection and turbocharging |      |
| Displacement in cc (valves per cylinder)       | 3993 (4)                                                      |      |
| Max. output <sup>1</sup> in kW at rpm          | 412/5700-6600                                                 |      |
| Max. torque in Nm at rpm                       | 700/1750-5500                                                 |      |
| <b>Power transmission/wheels</b>               |                                                               |      |
| Drive type                                     | quattro® permanent all-wheel drive                            |      |
| Transmission type                              | 8-speed tiptronic                                             |      |
| Wheels                                         | Forged aluminium wheels, 9 J x 20                             |      |
| Tyres                                          | 275/35 R 20 <sup>2</sup>                                      |      |
| <b>Weights/capacities</b>                      |                                                               |      |
| Unladen weight <sup>3</sup> in kg              | 1995                                                          |      |
| Gross vehicle weight in kg                     | 2505                                                          |      |
| Permissible roof load limit in kg              | 100                                                           |      |
| Fuel tank capacity, approx. in l               | 65                                                            |      |
| <b>Performance/consumption<sup>4</sup></b>     |                                                               |      |
| Top speed in km/h                              | 250 <sup>5</sup>                                              |      |
| Acceleration 0-100 km/h in s                   | 3.9                                                           |      |
| Fuel grade                                     | Sulphur-free super plus RON 98 <sup>6</sup>                   |      |
| Fuel consumption <sup>7</sup> in l/100 km      | urban                                                         | 13.9 |
|                                                | extra-urban                                                   | 7.5  |
|                                                | combined                                                      | 9.8  |
| CO <sub>2</sub> emissions <sup>7</sup> in g/km | urban                                                         | 324  |
|                                                | extra-urban                                                   | 174  |
|                                                | combined                                                      | 229  |
| Efficiency class                               | E                                                             |      |
| Emission standard                              | EU5                                                           |      |

**Explanatory notes**

<sup>1</sup> The figure given was calculated using the specified measuring procedure (current version of Directive 80/1269/EEC).

<sup>2</sup> You will find specifications on the technical characteristics of tyres on page 63.

<sup>3</sup> Unladen vehicle weight includes driver (68 kg), luggage (7 kg) and fuel tank 90% full, calculated in accordance with the current version of Directive 92/21/EEC. Optional equipment may increase the car's unladen weight and drag coefficient, whereupon the possible payload limit and the top speed will be reduced accordingly.

<sup>4</sup> A vehicle's fuel consumption and CO<sub>2</sub> emissions do not just depend on how efficiently the vehicle uses the fuel, but are also influenced by driving behaviour and other non-technical factors. CO<sub>2</sub> is the greenhouse gas primarily responsible for global warming.

<sup>5</sup> Regulated.

<sup>6</sup> We recommend using sulphur-free SuperPlus unleaded RON 98 in accordance with DIN EN 228. If this is not available, use sulphur-free super unleaded RON 95 in accordance with DIN EN 228; power output will be slightly reduced. Unleaded RON 95 fuel with a maximum ethanol content of 10% (E10) can generally be used. Fuel consumption details refer to operation with RON 95 fuel in accordance with 692/2008/EC.

<sup>7</sup> The figures given were calculated using the specified measuring procedures. The figures do not refer to one individual vehicle and do not form part of any offer, but rather should be used purely for purposes of comparison between the different vehicle models.

**Important note**



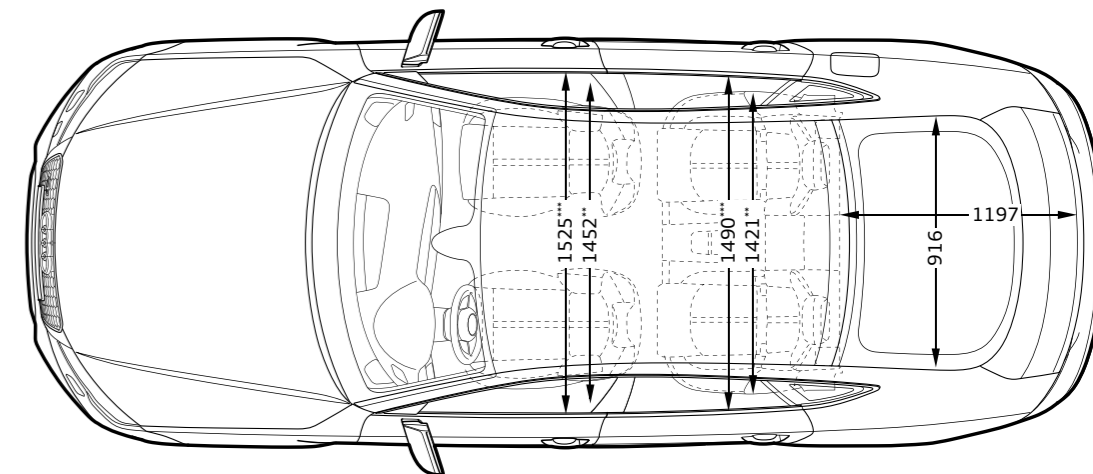
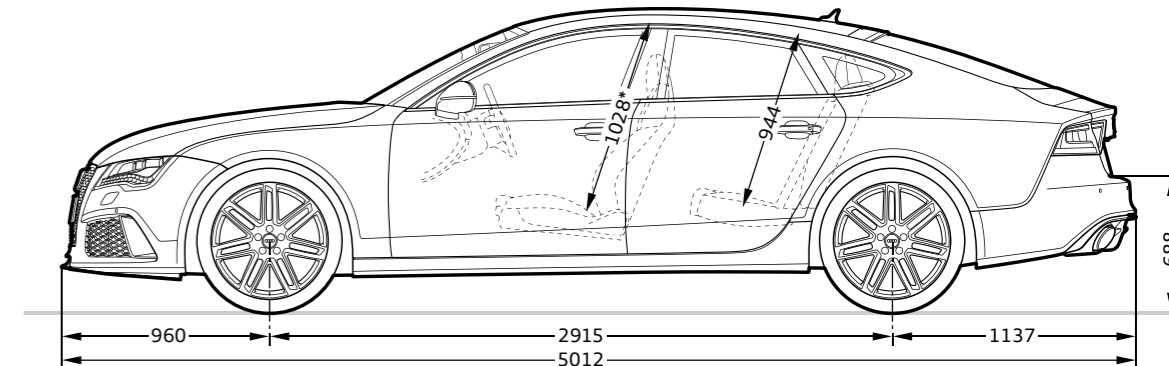
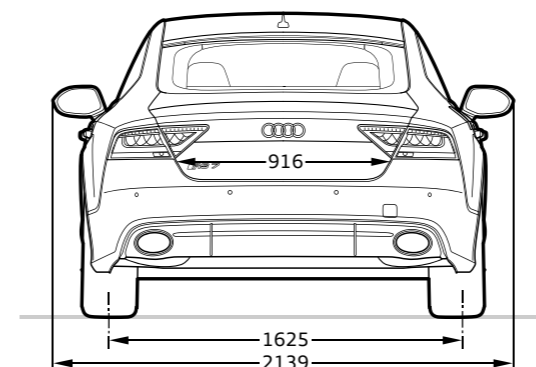
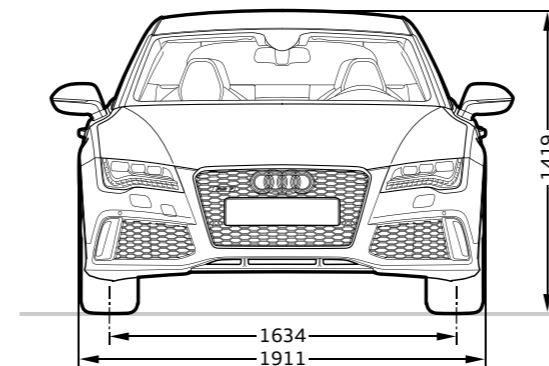











Inspections are due as shown by the service display.



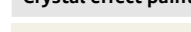

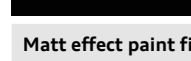



**Audi RS 7 Sportback****Dimensions in millimetres.**





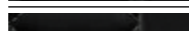

Dimensions were measured with vehicle at unladen weight.

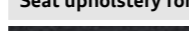
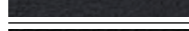
Luggage compartment volume 535/1,390 l (measured by the VDA method using 200 x 100 x 50 mm blocks; second value with rear seat backrest folded down and vehicle loaded up to roof height). Turning circle approx. 11.9 m.

\* Maximum headroom. \*\* Shoulder room width. \*\*\* Elbow room width.

|                                                                                                                                                                         |                                     |
|-------------------------------------------------------------------------------------------------------------------------------------------------------------------------|-------------------------------------|
| <b>Solid/metallic paint finishes</b>                                                                                                                                    | <b>40</b>                           |
|  Ibis white                                                                             | <input type="checkbox"/>            |
|  Nardo grey                                                                             | <input type="checkbox"/>            |
|  Suzuka grey, metallic                                                                  | <input checked="" type="checkbox"/> |
| <b>Pearl effect paint finishes</b>                                                                                                                                      | <b>41</b>                           |
|  Daytona grey, pearl effect                                                             | <input checked="" type="checkbox"/> |
|  Misano red, pearl effect                                                               | <input checked="" type="checkbox"/> |
|  Phantom black, pearl effect                                                            | <input checked="" type="checkbox"/> |
| <b>Crystal effect paint finishes</b>                                                                                                                                    | <b>41</b>                           |
|  Prisma silver, crystal effect                                                          | <input checked="" type="checkbox"/> |
|  Estoril blue, crystal effect                                                           | <input checked="" type="checkbox"/> |
|  Panther black, crystal effect                                                          | <input checked="" type="checkbox"/> |
| <b>Matt effect paint finish</b>                                                                                                                                         | <b>41</b>                           |
|  Daytona grey, matt effect                                                              | <input checked="" type="checkbox"/> |
| <b>Customised paint finishes</b>                                                                                                                                        | <b>41</b>                           |
|  Audi exclusive customised paint finishes.                                              | <input checked="" type="checkbox"/> |
| <b>Wheels/tyres</b>                                                                                                                                                     | <b>42</b>                           |
|  20" forged aluminium wheels in 7-twin-spoke design, high-gloss turned finish           | <input type="checkbox"/>            |
|  21" cast aluminium wheels in 5-spoke blade design                                      | <input checked="" type="checkbox"/> |
|  21" cast aluminium wheels in 5-spoke blade design in matt titanium look, turned finish | <input checked="" type="checkbox"/> |
|  21" cast aluminium wheels in 5-spoke blade design in high-gloss black, turned finish   | <input checked="" type="checkbox"/> |

|                                                                                                                                                                             |                                     |
|-----------------------------------------------------------------------------------------------------------------------------------------------------------------------------|-------------------------------------|
|  20" cast aluminium winter wheels in 7-twin-spoke design                                  | <input checked="" type="checkbox"/> |
|  21" cast aluminium winter wheels in 5-spoke blade design                                | <input checked="" type="checkbox"/> |
| Anti-theft wheel bolts                                                                                                                                                      | <input type="checkbox"/>            |
| Tyre repair kit                                                                                                                                                             | <input type="checkbox"/>            |
| Tyre pressure monitoring system                                                                                                                                             | <input type="checkbox"/>            |
| Vehicle tool kit                                                                                                                                                            | <input type="checkbox"/>            |
| Vehicle jack                                                                                                                                                                | <input checked="" type="checkbox"/> |
| <b>Seats</b>                                                                                                                                                                | <b>44</b>                           |
| RS sport seats, front                                                                                                                                                       | <input type="checkbox"/>            |
| Comfort seats, front, with memory function                                                                                                                                  | <input checked="" type="checkbox"/> |
| <b>Seat upholstery for RS sport seats, front</b>                                                                                                                            | <b>44</b>                           |
|  Alcantara/leather, black with diamond-patterned stitching in black                      | <input type="checkbox"/>            |
|  Valcona leather, black with honeycomb-patterned stitching in black                      | <input checked="" type="checkbox"/> |
|  Valcona leather, black with honeycomb-patterned stitching in rock grey                  | <input checked="" type="checkbox"/> |
|  Valcona leather, lunar silver with honeycomb-patterned stitching in rock grey           | <input checked="" type="checkbox"/> |
|  Audi exclusive Valcona leather, black with honeycomb-patterned stitching in crimson red | <input checked="" type="checkbox"/> |
|  Audi exclusive leather upholstery and trim.                                             | <input checked="" type="checkbox"/> |
| <b>Seat upholstery for comfort seats, front</b>                                                                                                                             | <b>45</b>                           |
|  Milano leather, black                                                                   | <input checked="" type="checkbox"/> |
|  Perforated Valcona leather, black                                                       | <input checked="" type="checkbox"/> |
|  Audi exclusive leather upholstery and trim.                                             | <input checked="" type="checkbox"/> |
| <b>Leather upholstery and trim</b>                                                                                                                                          | <b>46</b>                           |
| Alcantara/leather combination                                                                                                                                               | <input type="checkbox"/>            |
| Milano leather                                                                                                                                                              | <input checked="" type="checkbox"/> |
| Valcona leather with honeycomb-patterned stitching                                                                                                                          | <input checked="" type="checkbox"/> |
| Perforated Valcona leather                                                                                                                                                  | <input checked="" type="checkbox"/> |
| Leather-covered armrests in the door trims                                                                                                                                  | <input type="checkbox"/>            |

|                                                                                                               |                                     |
|---------------------------------------------------------------------------------------------------------------|-------------------------------------|
| Leather-covered airbag cover on steering wheel                                                                | <input checked="" type="checkbox"/> |
| Audi exclusive leather package including airbag cover                                                         | <input checked="" type="checkbox"/> |
| Extended Audi exclusive leather package                                                                       | <input checked="" type="checkbox"/> |
| Audi exclusive leather upholstery and trim in Alcantara/Valcona leather (package 1)                           | <input checked="" type="checkbox"/> |
| Audi exclusive leather upholstery and trim in Valcona leather (package 1)                                     | <input checked="" type="checkbox"/> |
| Audi exclusive leather upholstery and trim in Valcona leather (package 2)                                     | <input checked="" type="checkbox"/> |
| Piping for Audi exclusive comfort seats                                                                       | <input checked="" type="checkbox"/> |
| Audi exclusive leather upholstery and trim in Valcona leather with honeycomb-patterned stitching (package 1)  | <input checked="" type="checkbox"/> |
| Audi exclusive leather upholstery and trim in Valcona leather with honeycomb-patterned stitching (package 2)  | <input checked="" type="checkbox"/> |
| Audi exclusive design package in Valcona leather with honeycomb-patterned stitching                           | <input checked="" type="checkbox"/> |
| <b>Inlays</b>                                                                                                 | <b>47</b>                           |
|  Carbon                    | <input type="checkbox"/>            |
|  Piano finish, black       | <input checked="" type="checkbox"/> |
|  Aluminium/Beaufort, black | <input checked="" type="checkbox"/> |
|  Aluminium Race            | <input checked="" type="checkbox"/> |
|  Matt brushed aluminium    | <input checked="" type="checkbox"/> |
|  Audi exclusive inlays     | <input checked="" type="checkbox"/> |
| <b>Equipment packages</b>                                                                                     | <b>48</b>                           |
| Convenience package                                                                                           | <input checked="" type="checkbox"/> |
| Dynamic package                                                                                               | <input checked="" type="checkbox"/> |
| Dynamic package plus                                                                                          | <input checked="" type="checkbox"/> |
| <b>Light</b>                                                                                                  | <b>48</b>                           |
| xenon plus                                                                                                    | <input type="checkbox"/>            |
| adaptive light including variable headlight range control                                                     | <input checked="" type="checkbox"/> |
| LED headlights                                                                                                | <input checked="" type="checkbox"/> |
| High-beam assist                                                                                              | <input checked="" type="checkbox"/> |
| LED rear lights                                                                                               | <input type="checkbox"/>            |
| Adaptive brake light                                                                                          | <input type="checkbox"/>            |
| Light/rain sensor                                                                                             | <input type="checkbox"/>            |
| Ambient lighting                                                                                              | <input type="checkbox"/>            |

|                                                                                                            |                                     |
|------------------------------------------------------------------------------------------------------------|-------------------------------------|
| <b>Mirrors</b>                                                                                             | <b>48</b>                           |
| Exterior mirrors with integrated LED indicators                                                            | <input type="checkbox"/>            |
| Exterior mirrors, electrically adjustable and heated, with memory function                                 | <input checked="" type="checkbox"/> |
| Exterior mirrors, electrically adjustable, heated and folding, with memory function                        | <input checked="" type="checkbox"/> |
| Exterior mirrors, electrically adjustable, heated and folding, automatically dimming, with memory function | <input checked="" type="checkbox"/> |
| Exterior mirror housings in matt aluminium look                                                            | <input type="checkbox"/>            |
| Exterior mirror housings painted in body colour                                                            | <input checked="" type="checkbox"/> |
| Exterior mirror housings in carbon                                                                         | <input checked="" type="checkbox"/> |
| Interior mirror, dimming                                                                                   | <input type="checkbox"/>            |
| Interior mirror, automatically dimming                                                                     | <input checked="" type="checkbox"/> |
| <b>Roof system</b>                                                                                         | <b>49</b>                           |
| Slide-and-tilt glass sunroof                                                                               | <input checked="" type="checkbox"/> |
| <b>Closing systems</b>                                                                                     | <b>49</b>                           |
| Remote control key                                                                                         | <input type="checkbox"/>            |
| Engine start-stop button                                                                                   | <input type="checkbox"/>            |
| Convenience key                                                                                            | <input checked="" type="checkbox"/> |
| Luggage compartment lid, electrically opening and closing                                                  | <input type="checkbox"/>            |
| Convenience key including sensor-controlled luggage compartment lid release                                | <input checked="" type="checkbox"/> |
| Power-assisted door closing                                                                                | <input checked="" type="checkbox"/> |
| Garage door opener (HomeLink)                                                                              | <input checked="" type="checkbox"/> |
| Anti-theft alarm                                                                                           | <input type="checkbox"/>            |
| Preparation for tracking system                                                                            | <input checked="" type="checkbox"/> |
| <b>Glazing</b>                                                                                             | <b>49</b>                           |
| Heat-insulating glass                                                                                      | <input type="checkbox"/>            |
| Insulating/acoustic glass                                                                                  | <input checked="" type="checkbox"/> |
| Dark-tinted windows (privacy glazing)                                                                      | <input checked="" type="checkbox"/> |
| Insulating/acoustic glass and dark-tinted windows (privacy glazing)                                        | <input checked="" type="checkbox"/> |
| Sun visors                                                                                                 | <input type="checkbox"/>            |
| Sun screen                                                                                                 | <input checked="" type="checkbox"/> |

Standard equipment    Optional equipment

Country-specific variations possible. Please find out from your local Audi partner which equipment is standard and what optional equipment is available in your country.

|                                                                                                  |                                     |
|--------------------------------------------------------------------------------------------------|-------------------------------------|
| <b>Further exterior equipment</b>                                                                | <b>49</b>                           |
| Trim strips                                                                                      | <input type="checkbox"/>            |
| Audi Singleframe                                                                                 | <input type="checkbox"/>            |
| RS bumpers                                                                                       | <input type="checkbox"/>            |
| Matt aluminium design package including funnel-shaped air intake with quattro® logo              | <input checked="" type="checkbox"/> |
| Carbon design package including funnel-shaped air intake with quattro® logo                      | <input checked="" type="checkbox"/> |
| RS exhaust system                                                                                | <input type="checkbox"/>            |
| RS sport exhaust system                                                                          | <input checked="" type="checkbox"/> |
| Rear spoiler                                                                                     | <input type="checkbox"/>            |
| Model name/logo                                                                                  | <input type="checkbox"/>            |
| Sill extensions                                                                                  | <input type="checkbox"/>            |
| Engine cover                                                                                     | <input checked="" type="checkbox"/> |
| <b>Seats/seating comfort</b>                                                                     | <b>50</b>                           |
| 4-way lumbar support for the front seats                                                         | <input type="checkbox"/>            |
| Front seats, electrically adjustable with memory function for the driver seat                    | <input checked="" type="checkbox"/> |
| RS sport seats in the rear                                                                       | <input type="checkbox"/>            |
| RS sport seats in the rear including fold-out centre armrest                                     | <input checked="" type="checkbox"/> |
| Rear seat system with 2 seats                                                                    | <input checked="" type="checkbox"/> |
| Massage function, front                                                                          | <input checked="" type="checkbox"/> |
| Seat ventilation, front                                                                          | <input checked="" type="checkbox"/> |
| Seat heating, front                                                                              | <input checked="" type="checkbox"/> |
| Seat heating, front and rear                                                                     | <input checked="" type="checkbox"/> |
| Centre armrest, front                                                                            | <input type="checkbox"/>            |
| ISOFIX child seat mounting for the rear seats                                                    | <input type="checkbox"/>            |
| ISOFIX child seat mounting for the front-passenger seat                                          | <input checked="" type="checkbox"/> |
| <b>Steering wheels/selector levers/controls</b>                                                  | <b>50</b>                           |
| RS leather-covered multifunction sport steering wheel in 3-spoke design, flattened at the bottom | <input type="checkbox"/>            |
| RS leather-covered multifunction sport steering wheel in 3-spoke design                          | <input checked="" type="checkbox"/> |
| Leather-covered multifunction sport steering wheel in 3-spoke design, heated                     | <input checked="" type="checkbox"/> |
| Steering wheel adjustment, electric                                                              | <input type="checkbox"/>            |
| RS selector lever knob in perforated leather                                                     | <input type="checkbox"/>            |

|                                                                                  |                                     |
|----------------------------------------------------------------------------------|-------------------------------------|
| Audi exclusive leather steering-wheel rim                                        | <input checked="" type="checkbox"/> |
| Audi exclusive leather controls                                                  | <input checked="" type="checkbox"/> |
| Audi exclusive controls in black suede                                           | <input checked="" type="checkbox"/> |
| <b>Climate control</b>                                                           | <b>50</b>                           |
| 4-zone deluxe automatic air conditioning                                         | <input type="checkbox"/>            |
| <b>Luggage securing and storage systems</b>                                      | <b>51</b>                           |
| Storage compartments                                                             | <input type="checkbox"/>            |
| Glove compartment                                                                | <input type="checkbox"/>            |
| Storage package                                                                  | <input type="checkbox"/>            |
| Cup holders                                                                      | <input type="checkbox"/>            |
| Luggage compartment                                                              | <input type="checkbox"/>            |
| Bag hooks                                                                        | <input type="checkbox"/>            |
| Reversible mat                                                                   | <input checked="" type="checkbox"/> |
| Through-loading facility                                                         | <input checked="" type="checkbox"/> |
| Through-loading facility with removable ski/snowboard bag                        | <input checked="" type="checkbox"/> |
| <b>Further interior equipment</b>                                                | <b>51</b>                           |
| Pedals and footrest in aluminium look                                            | <input type="checkbox"/>            |
| Floor mats, front and rear                                                       | <input type="checkbox"/>            |
| Audi exclusive floor mats with RS 7 logo                                         | <input checked="" type="checkbox"/> |
| Audi exclusive floor mats with RS 7 logo and coloured leather piping             | <input checked="" type="checkbox"/> |
| Audi exclusive floor mats                                                        | <input checked="" type="checkbox"/> |
| Audi exclusive carpet and floor mats                                             | <input checked="" type="checkbox"/> |
| Door sill trims                                                                  | <input type="checkbox"/>            |
| Aluminium look in the interior                                                   | <input type="checkbox"/>            |
| Surround for instrument cluster                                                  | <input type="checkbox"/>            |
| Headlining in cloth                                                              | <input type="checkbox"/>            |
| Headlining in Alcantara, black                                                   | <input checked="" type="checkbox"/> |
| Headlining in Alcantara, black with Audi exclusive coloured decorative stitching | <input checked="" type="checkbox"/> |
| Cigarette lighter and ashtray                                                    | <input checked="" type="checkbox"/> |
| Non-smoker version                                                               | <input type="checkbox"/>            |

|                                                                          |                                     |
|--------------------------------------------------------------------------|-------------------------------------|
| <b>MMI® and navigation systems</b>                                       | <b>51</b>                           |
| MMI® navigation plus with MMI touch                                      | <input type="checkbox"/>            |
| MMI® touch                                                               | <input type="checkbox"/>            |
| Driver information system with 7-inch colour display                     | <input type="checkbox"/>            |
| Attention assist                                                         | <input type="checkbox"/>            |
| <b>Radio and TV systems</b>                                              | <b>52</b>                           |
| Digital Audio Broadcasting                                               | <input checked="" type="checkbox"/> |
| Digital TV reception                                                     | <input checked="" type="checkbox"/> |
| Audi sound system                                                        | <input type="checkbox"/>            |
| BOSE surround sound                                                      | <input checked="" type="checkbox"/> |
| Bang & Olufsen Advanced Sound System                                     | <input checked="" type="checkbox"/> |
| CD changer                                                               | <input checked="" type="checkbox"/> |
| DVD/CD changer                                                           | <input checked="" type="checkbox"/> |
| Audi music interface                                                     | <input checked="" type="checkbox"/> |
| Adapter cable set for Audi music interface                               | <input checked="" type="checkbox"/> |
| Adapter cable set plus for Audi music interface                          | <input checked="" type="checkbox"/> |
| Preparation for Rear Seat Entertainment                                  | <input checked="" type="checkbox"/> |
| <b>Telephone and communication</b>                                       | <b>52</b>                           |
| Bluetooth interface                                                      | <input type="checkbox"/>            |
| Preparation for mobile phone (Bluetooth)                                 | <input checked="" type="checkbox"/> |
| Bluetooth car phone                                                      | <input checked="" type="checkbox"/> |
| Audi connect <sup>1</sup> including car phone                            | <input checked="" type="checkbox"/> |
| Handset, front, for the car phone                                        | <input checked="" type="checkbox"/> |
| <b>Assistance systems</b>                                                | <b>53</b>                           |
| Audi pre sense basic                                                     | <input checked="" type="checkbox"/> |
| adaptive cruise control with Stop&Go function incl. Audi pre sense front | <input checked="" type="checkbox"/> |
| Audi active lane assist                                                  | <input checked="" type="checkbox"/> |
| Audi side assist including Audi pre sense rear                           | <input checked="" type="checkbox"/> |
| Assistance package including Audi pre sense plus                         | <input checked="" type="checkbox"/> |
| Night vision assistant with highlighting of detected pedestrians         | <input checked="" type="checkbox"/> |

|                                                          |                                     |
|----------------------------------------------------------|-------------------------------------|
| Head-up display                                          | <input checked="" type="checkbox"/> |
| Cruise control                                           | <input type="checkbox"/>            |
| Camera-based speed limit display                         | <input checked="" type="checkbox"/> |
| Hold assist                                              | <input type="checkbox"/>            |
| Parking system plus                                      | <input type="checkbox"/>            |
| Park assist with display of surroundings                 | <input checked="" type="checkbox"/> |
| Rearview camera                                          | <input checked="" type="checkbox"/> |
| Front and rearview cameras                               | <input checked="" type="checkbox"/> |
| <b>Suspensions/brakes</b>                                | <b>54</b>                           |
| Audi drive select                                        | <input type="checkbox"/>            |
| Electromechanical power steering                         | <input type="checkbox"/>            |
| Dynamic steering                                         | <input checked="" type="checkbox"/> |
| RS adaptive air suspension                               | <input type="checkbox"/>            |
| RS sport suspension plus with Dynamic Ride Control (DRC) | <input checked="" type="checkbox"/> |
| RS brake system                                          | <input type="checkbox"/>            |
| Brake callipers painted high-gloss black                 | <input type="checkbox"/>            |
| Brake callipers painted high-gloss red <sup>2</sup>      | <input checked="" type="checkbox"/> |
| Ceramic brake                                            | <input checked="" type="checkbox"/> |
| Electromechanical parking brake                          | <input type="checkbox"/>            |
| <b>Technology/safety</b>                                 | <b>55</b>                           |
| Body, galvanised                                         | <input type="checkbox"/>            |
| Side impact protection                                   | <input type="checkbox"/>            |
| Airbags                                                  | <input type="checkbox"/>            |
| Side airbags, front and head airbag system               | <input type="checkbox"/>            |
| Side airbags, rear                                       | <input checked="" type="checkbox"/> |
| Child-proof lock                                         | <input type="checkbox"/>            |
| Integrated head restraint system                         | <input type="checkbox"/>            |
| Instrument cluster                                       | <input type="checkbox"/>            |
| Safety steering column                                   | <input type="checkbox"/>            |
| Battery energy management                                | <input type="checkbox"/>            |

Standard equipment     Optional equipment

Country-specific variations possible. Please find out from your local Audi partner which equipment is standard and what optional equipment is available in your country.

<sup>1</sup>For information on when the Audi connect services will be available, please contact your Audi partner.    <sup>2</sup>For information on when this feature will be available, please contact your Audi partner.

|                                                    |                                     |
|----------------------------------------------------|-------------------------------------|
| <b>Technology/safety</b> (continued)               | <b>55</b>                           |
| Seat belts                                         | <input type="checkbox"/>            |
| Audi exclusive seat belts                          | <input checked="" type="checkbox"/> |
| Warning triangle                                   | <input checked="" type="checkbox"/> |
| First-aid kit                                      | <input checked="" type="checkbox"/> |
| 75 l fuel tank                                     | <input checked="" type="checkbox"/> |
| Antilock Brake System (ABS)                        | <input type="checkbox"/>            |
| Anti-Slip Regulation (ASR)                         | <input type="checkbox"/>            |
| Electronic Differential Lock (EDL)                 | <input type="checkbox"/>            |
| Electronic Stabilisation Control (ESC)             | <input type="checkbox"/>            |
| tiptronic                                          | <input type="checkbox"/>            |
| quattro®                                           | <input type="checkbox"/>            |
| quattro® with sport differential                   | <input checked="" type="checkbox"/> |
| Electronic regulation of the top speed at 280 km/h | <input checked="" type="checkbox"/> |
| Recuperation                                       | <input type="checkbox"/>            |
| Start-stop system                                  | <input type="checkbox"/>            |
| <b>Audi Extended Warranty</b>                      | <b>55</b>                           |
| Audi Extended Warranty                             | <input checked="" type="checkbox"/> |

Equipment for the Audi RS 7 Sportback illustrated (p. 4–21):

Paint finish: Daytona grey, pearl effect





Wheels: cast aluminium wheels in 5-spoke blade design

Seats/seat upholstery: RS sport seats, front, in Valcona leather, black, with honeycomb-patterned stitching in rock grey

Inlays: carbon

#### Classifications of tyre parameters

The table shows the range of fuel efficiency, wet grip and exterior noise emission classes for the different tyre sizes of the Audi RS 7 Sportback.

|              | Tyre size   | Fuel efficiency class | Wet grip class | Exterior noise emission class                                                                                                                                                   |
|--------------|-------------|-----------------------|----------------|---------------------------------------------------------------------------------------------------------------------------------------------------------------------------------|
| Summer tyres | 275/35 R 20 | E                     | C–A            | 73–72                                                                                        |
|              | 275/30 R 21 | F–E                   | C–A            | 75–71  –  |
| Winter tyres | 245/40 R 20 | E                     | C              | 73                                                                                           |
|              | 275/30 R 21 | C                     | C              | 73                                                                                           |

It is not possible to order a specific tyre. Ask your Audi partner about the range of tyres available in your country.

Standard equipment     Optional equipment

Country-specific variations possible. Please find out from your local Audi partner which equipment is standard and what optional equipment is available in your country.



### Responsibility

Living up to our responsibilities is a principle that is firmly anchored in Audi strategy. Alongside commercial success and international competitiveness, our responsibility toward company employees and society as a whole is a key consideration, as is protecting the environment and conserving resources. And what is true in the details – our catalogues are printed on FSC-certified paper – also holds in general: Audi develops cars that are not only sporty and emotive but also ever more efficient. In the long run, Audi wants its products to

allow CO<sub>2</sub>-neutral mobility. Seeing to it that production in Audi plants gradually becomes CO<sub>2</sub>-neutral is another aspect of our comprehensive approach. Audi is also committed to society – particularly in the fields of education, technology and social projects. At Audi, sustainability is closely linked with how we see the future: the Audi Urban Future Initiative sees Audi working with international experts to get to the root of future urban challenges and trends in mobility.

# Discover the world of Audi.



Choosing an Audi means choosing a brand that offers more. More individuality. More exclusivity. More fascination.

### The Audi experience

The fascination of Audi can be experienced in many different ways. Audi City in London, for example, gives you digital access to all models at their actual size and in real time. And of course it is always worth visiting one of the major motor shows. This is where Audi always presents its new models and invites you to take a look at how the future is being shaped with "Vorsprung durch Technik". Anyone interested in seeing how Audi is already putting this into practice will find fascinating insight in the "Vorsprung durch Technik" online special at [www.audi.com](http://www.audi.com). But a look back can also be rewarding:

at the Audi mobile museum in Ingolstadt, history and high-tech go hand in hand. A total of 130 historic exhibits and state-of-the-art forms of presentation make for a thrilling symbiosis. Plus, Audi driving experience allows you to live the excitement and countless possibilities of current Audi models. Here, pure driving enjoyment is combined with valuable learning effects. This is ensured by a team of specially trained and highly qualified instructors who provide practical tips to help you optimise your driving skills.



### Team spirit

Motorsport is a driving force behind the brand. For years Audi has been among the champions in various racing series, for instance the 24 Hours of Le Mans or the DTM German Touring Car Masters. The values that are crucial in many different areas of sports are also central ones for Audi: precision, passion and technology. No coincidence then that Audi has been sponsoring sporting

events for many years. In the world of winter sports, for example, Audi has been the main sponsor of the German Ski Association (DSV) for almost three decades and has also partnered 14 other national alpine teams. In football, we support national and international teams. And Audi is also a partner for the German Olympic Sports Confederation.

### www.audi.com

Information on all subjects mentioned can be found on our website: [www.audi.com](http://www.audi.com).

-  [www.audi.com](http://www.audi.com)
-  [configurator.audi.com](http://configurator.audi.com)
-  [www.audi.com/vorsprung-durch-technik](http://www.audi.com/vorsprung-durch-technik)
-  [www.audi.com/driving](http://www.audi.com/driving)
-  [www.audi.com/cr](http://www.audi.com/cr)



**quattro GmbH**  
85045 Ingolstadt  
[www.audi.com](http://www.audi.com)  
Valid from May 2013

Printed in Germany  
358/1262.00.18

The models and equipment versions illustrated and described in this brochure and some of the services listed are not available in all countries. Some of the cars illustrated are equipped with optional features for which an extra charge is made. Details concerning the delivery specifications, appearance, performance, dimensions and weights, fuel consumption and running costs of the vehicle were correct to the best of our knowledge at the time of going to press. Deviations from the colours and shapes shown in the illustrations may occur. No liability is accepted for errors and printing errors. The right to introduce modifications is reserved. Not to be reproduced, including in part, without the written approval of AUDI AG.

This brochure is printed on paper made from pulp bleached without the use of chlorine.

