

**RS 3**



**Audi Sport**





	Page	
<b>Fascination</b>		
	4	Audi RS 3 Sportback
<b>Technology</b>		
	20	Innovations
	22	Audi Sport
	24	Performance
	26	quattro®
	28	Dynamics
	30	Audi drive select
<b>Equipment</b>		
	34	Style guides
	36	Paint finishes
	38	Wheels/tyres
	40	Seats
	42	Headlining
	43	Inlays
	44	Equipment packages
	44	Lights
	45	Design
	45	Steering wheels/controls
	46	Comfort
	47	Infotainment
	49	Assistance systems
	51	Technology/safety
	51	Audi Extended Warranty
<b>Other</b>		
	52	Technical data
	53	Dimensions
	54	Index
	58	The fascination of Audi

The equipment for the vehicle illustrated in the Fascination section can be found on page 57.  
 The fuel consumption and CO<sub>2</sub> emission figures can be found on page 52.



# Feel the character.

The new Audi RS 3 Sportback.

Combines contradictory characters: the new Audi RS 3 Sportback. It brings together what seems mutually exclusive. Breathtaking performance and outstanding practicality. Paired with an unmistakable sound, the dynamism of a sports car and a powerful look. Together, these properties form its character. A character you can feel during every trip.

The fuel consumption and CO<sub>2</sub> emission figures can be found on page 52.

## No warm-up necessary. Inspiring from the word go.

The new Audi RS 3 Sportback impressively continues the success story of the legendary 5-cylinder engines: with a power output of 270 kW and a maximum torque of 465 Nm, the 2.5 litre TFSI engine guarantees outstanding driving dynamics and a distinctive sound. No surprise then that this engine won the "International Engine of the Year Award"\* in 2014 for the fifth time in a row. Yet the real winner is you.

\*Awarded in the category "2 litre to 2.5 litre"  
([www.ukipme.com/engineoftheyear](http://www.ukipme.com/engineoftheyear)).

The fuel consumption and CO<sub>2</sub> emission figures can be found on page 52.





## It's more than a car. It's a trophy.

Clear lines and a powerful design – with the new Audi RS 3 Sportback every trip feels like a lap of honour. The dynamic side lines are impressive, with accentuated wheel arches, sill extensions and exclusive 19-inch cast aluminium wheels in 5-arm rotor design. The shaped RS roof edge spoiler and RS bumper with striking diffuser insert characterise the athletic rear. As does the RS exhaust system with its large oval tailpipes. And these are only a few of the many details that make it a real eye-catcher.

The fuel consumption and CO<sub>2</sub> emission figures can be found on page 52.





## Turns the pavement into a grandstand.

The new Audi RS 3 Sportback is inspiring – both on the move and at a standstill: with its characteristic Audi Singleframe in matt aluminium look and black gloss honeycomb grid as well as the unmistakable look of the LED daytime running lights. The central air inlet duct and the large, curved blade mould the front and underline its powerful charisma. Anyone wanting to accentuate the appearance of their new Audi RS 3 Sportback even further can do so with styling packages in matt aluminium or gloss black. Guaranteeing that all eyes will be on them.

The fuel consumption and CO<sub>2</sub> emission figures can be found on page 52.



## Enough room for a co-pilot and three spectators.

No matter where you sit – you always get the best seat. Because the interior of the new Audi RS 3 Sportback impresses with a clear design, high-quality materials and first-class workmanship. From the door sill trims with classy aluminium inlays and RS 3 logo and the standard fine Nappa leather upholstery and trim to the sporty RS controls. And the optional RS design package allows you to highlight the sporty black of the interior by adding red details to the air vents, armrests in the doors, knee pads, seat belts and floor mats featuring the RS 3 logo. A thrill for everyone on board – whether they're behind the wheel or not.

The fuel consumption and CO<sub>2</sub> emission figures can be found on page 52.



## Supplies the driver with important information. Even without pit-to-car communication.

Racing drivers would love to sit here: in the cockpit of the new Audi RS 3 Sportback. The perfectly executed interface between driver and vehicle. A multitude of information is clearly displayed on the RS instrument cluster. For less distraction and for outstanding control. The RS multifunction sport leather steering wheel with aluminium-look shift paddles is covered with an Alcantara/leather combination that is pleasant to grip when steering and changing gear. Numerous vehicle and infotainment functions can be operated easily and intuitively via the MMI. The contoured shape of the RS 3 sport seats – available on request – provide even more lateral support in challenging bends. The shoulder areas are adorned by a perforated diamond pattern and the seat backrests feature RS 3 embossing. Thus turning the interior into your very own pole position.

The fuel consumption and CO<sub>2</sub> emission figures can be found on page 52.





## Set the tone. With more than engine sound.

The new Audi RS 3 Sportback is convincing on every stretch of track. Thanks to the RS sport suspension, it inspires with high agility, impressive directional stability and precise steering characteristics. In addition, the optional RS sport suspension plus with Audi magnetic ride allows the damper setting to be varied in three stages. The RS brake system with wave brake discs at the front guarantees outstanding deceleration. The 19-inch ceramic brake\* is available for the front axle on request for even tougher requirements. Audi drive select can be used to modify not only the engine, transmission and steering characteristics, but also the distribution of torque of the quattro drive, the engine sound and other optional components. Pre-configured or adapted to your personal preferences. But always without compromise.

\*For information on when this feature will be available, please contact your Audi partner.  
The fuel consumption and CO<sub>2</sub> emission figures can be found on page 52.





## Experience fast pace. Even without a race licence.

The new Audi RS 3 Sportback is equipped with the S tronic 7-speed dual-clutch transmission. This means quick gear changing almost without a break in propulsive power. You decide whether you want to change gear using the shift paddles on the RS multifunction sport leather steering wheel, by nudging the RS selector lever or in automatic mode. The RS 3 has quattro permanent all-wheel drive for an even more dynamic drive and outstanding traction. Depending on the driving situation and the mode selected in Audi drive select, the drive force is distributed between the front and rear axle to all four wheels as required.

Feel the character of the new Audi RS 3 Sportback and experience its extraordinary performance.

The fuel consumption and CO<sub>2</sub> emission figures can be found on page 52.



# Vorsprung durch Technik.

The world is constantly changing. Technology is advancing at an ever faster pace. And in the process, more and more opportunities are opening up to you – nowhere more so than in the field of mobility. We are playing an instrumental role in shaping this progress with Vorsprung durch Technik. Striving to provide you with technology that enriches your life. Making sure that we don't just satisfy your expectations of mobility both today and in the future, but continue to surpass them.



## Audi Sport: Technologies from motor racing. Transferred to the road.

Thrilling performance. Whether it's works motorsport, customer racing or our high-performance models – you'll not get such a potent adrenalin rush anywhere else. Audi Sport utilises the expertise gained in motor racing to bring innovative technologies to series production. With unrivalled passion – for outstanding dynamism.





## Consistent power. Put to consistent use. The TFSI® engine.

Consistent power: the 2.5 litre TFSI engine with 270 kW. The maximum torque of 465 Nm lets you experience spontaneous responsiveness and impressive power delivery over the entire engine speed range. The Audi RS 3 Sportback accelerates from 0 to 100 km/h in just 4.3 seconds. Its propulsive power ends only at an electronically regulated 250 km/h, with the option of boosting the top speed to 280 km/h. In addition to all its sportiness, however, its efficiency is also convincing – thanks to the start-stop system and recuperation.

Fascinating sound: due to the firing order, the extraordinary 5 cylinder basic concept provides the Audi RS 3 Sportback with an unmistakable soundscape that can be influenced by the RS exhaust valve control. Thus, the engine that has been awarded with the “International Engine of the Year Award”\* for the fifth year in a row impresses not only with performance, torque and efficiency, but also with its remarkable sound.

Outstanding performance that is achieved in conjunction with the 7-speed S tronic. The dual-clutch transmission consisting of two transmission parts changes gears by changing the power-transmitting clutch. Precise gear changes at lightning speed and with virtually no break in propulsive power. For this purpose, S tronic provides the programs D (Drive) and S (Sport) in automatic mode. In manual mode, gears can be actively changed using shift paddles on the steering wheel or by nudging the selector lever – providing even greater driving enjoyment. And at the same time, efficient driving is supported by high efficiency and a seventh gear that has been designed as overdrive with long transmission.

\*Awarded in the category “2 litre to 2.5 litre” ([www.ukipme.com/engineoftheyear](http://www.ukipme.com/engineoftheyear)).  
The fuel consumption and CO<sub>2</sub> emission figures can be found on page 52.

## Superb roadholding.

### The quattro® permanent all-wheel drive.

Outstanding traction, improved handling dynamics and more driving safety. Or for short: quattro. Hardly any other drive system around transfers the engine's power to the road so effortlessly. The quattro drivetrain has been enhanced in the Audi RS 3 Sportback in order to transmit the enormous torque. Its electronically controlled and hydraulically operated multi-plate clutch ensures the drive torque is distributed between the front and rear axles as required and according to the driving situation. The rapid response and very fast reaction times of this system, which also allow the distribution of force to be influenced by Audi drive select, are particularly impressive. In addition, the wheel-selective torque control avoids undesirable wheel slip through targeted braking actions on all wheels. The result is precisely controlled and sporty handling with increased agility while maintaining superb traction – even in challenging driving situations.





## Bending the road to your will. RS suspensions and RS brake systems.

### RS brake systems

Demonstrate power: with the standard 19-inch RS brake system in the Audi RS 3 Sportback. The 8-piston fixed callipers at the front take powerful hold of the front wave brake discs, whose cast friction ring with a wave-shaped outer contour is connected to the aluminium brake disc chamber by means of steel pins. This so-called floating mounting ensures that the friction ring remains largely tension-free, thus improving stability when subjected to high temperatures. Axial perforation and cooling channels for internal ventilation increase the performance of the brake discs. The intelligent mix of materials and the characteristic geometry of the friction rings help reduce weight, thus improving the balance of unsprung masses.

The optional 19-inch ceramic brake system\* on the front axle is available for even tougher requirements. It features brake discs made out of a carbon-fibre-reinforced ceramic material which is based on hard silicon carbide with embedded high-strength carbon fibres. The result is enormous abrasion resistance, high mileages, reduced weight and resistance to high thermal loads.

### RS suspensions

Show character. Self-assured, sporty. With the RS sport suspension in the Audi RS 3 Sportback. Experience outstanding directional stability and excellent agility coupled with precise steering characteristics. The McPherson front axle with lower wishbones and the 4-link rear axle with separate spring/damper arrangement guarantee a sporty dynamic driving experience. With specially tuned characteristic spring and damper curves and adapted elasto-kinematics. Optionally available: the RS sport suspension plus with Audi magnetic ride for increased driving dynamics. For this, the characteristics of the adaptive shock absorber can be adjusted in three stages via Audi drive select. The damping forces vary over a large range, depending on the mode chosen. Their control depends on the driving situation and is regulated in fractions of a second. The electromechanical progressive steering with RS-specific characteristic curve provides additional dynamism. The steering ratio is adapted according to the steering angle, its steering support varies depending on speed. The low-position configuration ensures a spontaneous steering response, precise feedback from the road and even more fun while cornering. The steering also requires almost no energy when driving in a straight line, thus helping to reduce fuel consumption.

\*Please consult your Audi partner or national Audi website to find out more about the special features of the ceramic brake. For information on when this feature will be available, please contact your Audi partner. The fuel consumption and CO<sub>2</sub> emission figures can be found on page 52.

# Reach your destination. The way you want.

## Audi drive select.

Change character. With the standard Audi drive select in the Audi RS 3 Sportback. Individual vehicle components can be influenced at the push of a button – such as the engine characteristic, exhaust flap control, transmission mode, distribution of torque of the quattro drive and the steering torque of the electromechanical progressive steering – to adapt them to the prevailing driving situation. With four different modes including various settings: auto, comfort, dynamic and individual. auto for superior sporty quality. comfort for longer journeys. dynamic for more ambitious driving. And individual, so you configure the individual components yourself according to your preferences.

In addition, various optional systems can be adjusted. For example, the characteristic curves of the shock absorbers on the RS sport suspension plus with Audi magnetic ride can be varied in three levels: from comfortable rolling in comfort mode through to sporty, direct responsiveness in the dynamic setting. The adaptive cruise control can also be set either balanced or more spontaneous with regard to acceleration behaviour and reaction to the vehicle in front. In addition, the cornering light function of the optional adaptive light can also be adjusted in that the swivelling response of the xenon plus headlights is adapted to the mode selected in Audi drive select.

The fuel consumption and CO<sub>2</sub> emission figures can be found on page 52.





**As unique as you are.**  
The equipment options.

Sportiness, comfort, design, functionality – whatever you demand of your Audi, it offers you a wealth of custom options. Audi equipment versions are varied and high-quality and you can tailor them entirely to your needs.

## Character takes on many forms. Here are two of them.

What makes an Audi your Audi? Vehicle equipment entirely tailored to your needs. There are a wide range of options available to you to give your vehicle the exact touch you have in mind. More sportiness? More elegance? Let yourself be inspired.

### Audi RS 3 Sportback in Nardo grey

Cast aluminium wheels in 5-arm rotor design  
gloss anthracite grey, gloss turned finish\*

Gloss black styling package including  
quattro logo

RS bucket seats, front, in fine Nappa leather,  
black with contrasting stitching in grey

RS multifunction sport leather steering wheel in  
3-spoke design, flattened at the bottom

Audi exclusive inlays painted in Nardo grey



### Audi RS 3 Sportback in Sepang blue, pearl effect

Cast aluminium wheels in 5-arm rotor design

Matt aluminium styling package including  
quattro logo

RS sport seats, front, in fine Nappa leather,  
lunar silver with diamond pattern in grey

RS multifunction sport leather steering wheel in  
3-spoke design, flattened at the bottom

Aluminium Race inlays



The fuel consumption and CO<sub>2</sub> emission figures can be found on page 52.

\* Please note the special information relating to wheels on page 57.

## Your Audi is painted not just once. But four times.

When you choose a paint colour, choose one that best reflects your own personality. But whichever colour you opt for, you can count on the outstanding quality of our painting process. Though no thicker than a human hair, the layer of paint on an Audi is actually made up of four different coats. So not only do you look radiant in your Audi, the car is also optimally protected from environmental influences and wear. For its entire lifetime.



### | Solid paint finish

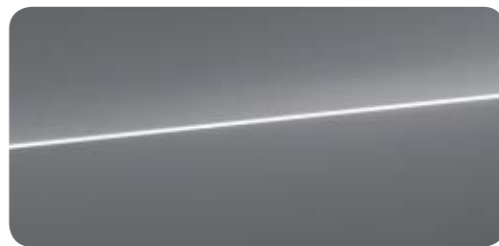

Nardo grey

### | Metallic paint finishes



Glacier white, metallic



Catalunya red, metallic

### | Pearl effect paint finishes



Daytona grey, pearl effect

### | Crystal effect paint finish



Panther black, crystal effect



Floret silver, metallic

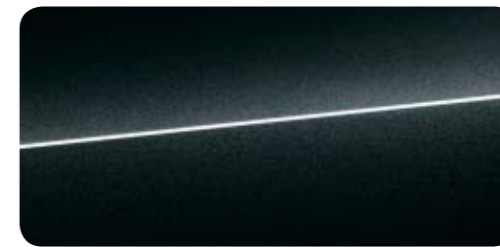

Mythos black, metallic



Sepang blue, pearl effect



Audi exclusive customised paint finishes



## The perfect connection between an Audi and the road: Audi wheels.

To make sure you have peace of mind for every metre of your drive, Audi puts its wheels through an exacting series of specialised test procedures. Hardness tests, for example, aim for maximum stability, while a copper accelerated salt spray test – CASS for short – using acetic acid guarantees the greatest possible corrosion protection. Thanks to these and many other measures, we can ensure that every Audi wheel offers maximum quality – even after scores of kilometres. No matter which of the numerous designs you choose.

### | Summer wheels



**Cast aluminium wheels in 5-arm rotor design**  
size 8 J x 19 with 235/35 R 19 tyres<sup>1</sup>



**Cast aluminium wheels in 5-arm rotor design in matt titanium look, gloss turned finish<sup>2</sup>**  
size 8.5 J x 19 at the front and 8 J x 19 at the rear with 255/30 R 19 tyres at the front and 235/35 R 19 tyres<sup>1</sup> at the rear

### | Winter wheels



**Cast aluminium winter wheels in 5-arm rotor design**  
size 8 J x 19 with 235/35 R 19 winter tyres<sup>1</sup>, can be fitted with snow chains, permissible top speed 240 km/h



**Cast aluminium wheels in 5-arm rotor design in titanium look, gloss turned finish<sup>2</sup>**  
size 8 J x 19 with 235/35 R 19 tyres<sup>1</sup>



**Cast aluminium wheels in 5-arm rotor design in gloss anthracite black, gloss turned finish<sup>2</sup>**  
size 8.5 J x 19 at the front and 8 J x 19 at the rear with 255/30 R 19 tyres at the front and 235/35 R 19 tyres<sup>1</sup> at the rear

<sup>1</sup>The model-specific standard and optional equipment can be found in the index from page 54 onwards.

<sup>2</sup>You will find specifications on the technical characteristics of tyres on page 57. <sup>3</sup>Please note the special information relating to wheels on page 52.



**Sport seats, front** [1]

The illustration shows sport seat, front, in fine Nappa leather, black with contrasting stitching in grey.



**RS sport seats, front** [2]

The illustration shows RS sport seat, front, in fine Nappa leather, black with diamond pattern in grey.



**RS bucket seats, front\*** [3]

The illustration shows RS bucket seat, front, in fine Nappa leather, black with contrasting stitching in red.

**| Leather**



**Fine Nappa leather, black with contrasting stitching in grey**

[1] [3]



**Fine Nappa leather, black with diamond pattern in red**

[2]



**Fine Nappa leather, black with contrasting stitching in red**

[1] [3]



**Fine Nappa leather, lunar silver with diamond pattern in grey**

[2]

**| Audi exclusive**



**Fine Nappa leather, black with diamond pattern in grey**

[2]



**Audi exclusive leather upholstery and trim**  
Individual choice of colour for leather/stitching

[1] [2]

**| Seat variants**

[1] Sport seats, front

[2] RS sport seats, front

[3] RS bucket seats, front\*

\*For information on when this feature will be available, please contact your Audi partner. The model-specific standard and optional equipment can be found in the index from page 54 onwards.

**| Leather upholstery and trim****Fine Nappa leather upholstery and trim with contrasting stitching**

for sport seats and RS bucket seats\*, front: seat upholstery and centre armrest, front, in fine Nappa leather with contrasting stitching, shoulder area at the front and rear on sport seats in velvet leather, door trim inserts in Alcantara; RS 3 embossing on the front-seat backrests

**Fine Nappa leather upholstery and trim with diamond pattern**

for RS sport seats, front: seat upholstery and centre armrest, front, in fine Nappa leather with contrasting stitching, shoulder area at the front and rear with diamond pattern and perforation in contrasting colour, door trim inserts in Alcantara; RS 3 embossing on the front-seat backrests

**Audi exclusive fine Nappa leather upholstery and trim\***

for sport seats and RS sport seats, front: seat upholstery and centre armrest, front, in fine Nappa leather, shoulder area at the front and rear on sport seats in velvet leather, on RS sport seats in fine Nappa leather with diamond pattern, door trim inserts in fine Nappa leather, RS 3 embossing on the front-seat backrests; black floor mats with coloured leather piping. Individual choice of colour for the leather and the stitching from the range of Audi exclusive colours.

**| Leather packages****RS design package**

armrests in the door trims in artificial leather, black with contrasting stitching in red, knee pads on the centre console in Alcantara, black with contrasting stitching in red, air vent tubes in red, seat belts in black with red edging as well as floor mats in black with RS 3 logo and contrasting stitching in red

**Extended interior elements mono.pur**

armrests in the door trims and knee pads on the centre console in artificial leather with contrasting stitching; with leather upholstery and trim with contrasting stitching or diamond pattern in red with knee pads in Alcantara with contrasting stitching

**Audi exclusive extended leather upholstery and trim\***

leather-covered armrests in the door trims and knee pads on the centre console in fine Nappa leather. Individual choice of colour for the leather and the stitching from the range of Audi exclusive colours.

**| Seat comfort****Driver seat, electrically adjustable**

with electrical adjustment of the seat height, fore/aft position, seat and backrest angle; manually adjustable front-passenger seat

**Front seats, electrically adjustable**

with electric adjustment of seat height, fore/aft position, seat and backrest angle

**4-way lumbar support for the front seats**

electric, with horizontal and vertical adjustment

**Seat heating, front**

heats up seat and backrest centre panels and seat side bolsters; separate adjustment in several stages for the driver and front-passenger side

**Centre armrest, front**

adjustable angle, can be adjusted lengthways

**| Seats in the rear****Rear seat backrest, folding**

can be split-folded 40:60 or fully

**| Headlining****Headlining in cloth**

in black or lunar silver, depending on the interior colour selected

## Experience fascination. Down to the last detail.

The exclusive Audi inlays emphasise the sporty ambience of your vehicle. At first sight. Be inspired by refined carbon, aluminium or a paint finish for the dashboard and door trims. High quality and precise workmanship harmoniously integrated in the interior.

**| Inlays**

3D-design "Black"



Aluminium Race



Carbon



Inlays painted in Audi exclusive colour\*

\*For information on when this feature will be available, please contact your Audi partner.

The model-specific standard and optional equipment can be found in the index from page 54 onwards.

Equipment packages   Lights   Design   Steering wheels/controls   Comfort   Infotainment   Assistance systems   Technology/safety   Audi Extended Warranty

## | Equipment packages

### Convenience package

includes:

- 4-way lumbar support for the front seats
- seat heating, front
- interior mirror, automatically dimming with light/rain sensor and windscreen with grey strip
- exterior mirrors, electrically adjustable, heated and folding, automatically dimming on the driver side including Audi sound system

## | Headlights/interior lighting

### Xenon plus

intensive road illumination, good uniformity and range thanks to headlights with durable gas discharge technology for dipped and high beam.

Automatic dynamic headlight range control that prevents oncoming traffic from being dazzled. Including homogeneous LED daytime running light strip, LED rear lights and headlight cleaning system

### adaptive light

pivoting xenon headlights, improved illumination of the course of the road due to dynamic cornering light (speed range from approx. 10 to 110 km/h) and static turning light, which switches on automatically from a specific steering angle or when the indicator has been engaged for a while at low vehicle speed, and illuminates the new direction in which the vehicle is travelling

### Variable headlight range control

The range of the headlights is continuously varied between dipped and high beam to suit ambient conditions, ensuring that the headlights provide good visibility without dazzling other road users. Within system limits. A camera on the interior mirror registers sources of light from other road users.

### LED headlights

allow precise, near-daylight illumination of the road; combines LED dipped beam, high beam, daytime running lights, motorway light, indicator and static turning light as well as all-weather light; including headlight cleaning system; motorway light that automatically increases headlight range from a speed of approximately 110 km/h; all-weather light to reduce the risk of the driver being dazzled when visibility is poor; striking light pattern in day and night design configurations including LED rear lights; low energy consumption and long service life

### High-beam assist

improves the driver's visibility and ensures a more relaxed drive thanks to the extra comfort and convenience. Depending on the traffic situation, the high beam automatically adjusts to dipped beam and vice versa. Working within system limits, automatically detects the headlights of oncoming traffic, the rear lights of other road users and built-up areas

### Light/rain sensor

automatic control of lights-on function, windscreen wipers and the coming home/leaving home function: delayed switch off/automatic switch on of headlights, rear and number plate lights, and in conjunction with xenon plus the LED daytime running lights when parking/opening the vehicle; includes windscreen with grey strip along the top edge

### LED rear lights

brake lights, tail lights, indicators and rear number plate lights in LED technology with low power consumption; with reversing lights and rear fog lights; 3rd brake light integrated in the RS roof edge spoiler

### Lighting package

anti-glare interior lighting in energy-saving and long-lasting LED technology, comprising:

- interior lighting at the front and rear with reading lights
- reflecting lighting for the centre console
- vanity mirrors, illuminated, for driver and front passenger
- illuminated cup holders
- entrance and footwell lighting as well as illuminated door openers
- luggage compartment light
- active door reflectors (light bulb)

## | Exterior design

### Model name/logo

RS 3 logo in the Audi Singleframe and on the luggage compartment lid

### Audi Singleframe

with radiator grille with honeycomb design in gloss black and 1-piece trim frame in a matt aluminium look; air inlet duct in gloss black

### RS bumpers

in sporty-dynamic design; with large air inlets in gloss black as well as horizontal blade painted in body colour, with diffuser insert in gloss black at the rear

### Wheel house extensions

front wing with accentuated wheel arches

### Sill extensions

painted in body colour

### Trim strips

on the side windows in matt aluminium look; B-pillar exterior trim and triangular panels on the rear doors in gloss black

### Roof rails

in matt aluminium look or black matt; for transportation of items, strong and aerodynamically shaped

### RS roof edge spoiler

on the luggage compartment lid, painted in body colour, aerodynamic inserts at the side in gloss black

### Engine cover with carbon trim

2-piece design engine cover in carbon

### Matt aluminium styling package

air inlet ducts and blade at the front, side frames and horizontal fin on the diffuser insert at the rear in matt aluminium look; including quattro logo in matt titanium grey in the air inlet duct at the front; in conjunction with the assistance package without quattro logo in the air inlet duct

### Gloss black styling package

frame of the radiator grille, blade at the front and trim strips on the side windows in gloss black; including quattro logo in matt titanium grey in the air inlet duct at the front; in conjunction with assistance package without quattro logo in the air inlet duct

## | Interior design

### Aluminium look in the interior

elements in aluminium look on air vents, glove compartment, mirror adjustment switch, frame around the inside door handles, window control switches, coin box, control buttons on the electromechanical parking brake and – if ordered – the hold assist

### Audi exclusive floor mats with RS 3 logo\*

in black, with embroidery on the front floor mats; piping and stitching in black

### Door sill trims with aluminium inlays

and RS 3 logo at the front

## | Steering wheels/controls

**RS multifunction sport leather steering wheel in 3-spoke design, flattened at the bottom** adjustable in height and reach; with shift paddles in aluminium look, RS 3 emblem and full-size airbag; flat-bottomed steering wheel rim upholstered in Alcantara/leather combination and contrasting stitching; for operating the infotainment features fitted in the vehicle

### RS selector lever knob in leather

with RS logo and decorative ring in aluminium look; selector lever gaiter in leather with contrasting stitching

### Audi exclusive leather controls\*

Leather-covered steering wheel rim, selector lever knob and gaiter in Audi exclusive leather. Individual choice of colour for the leather and the stitching from the range of Audi exclusive colours. Stitching on the steering wheel rim with specific Audi exclusive seam detail

### Audi exclusive controls in black suede\*

steering wheel rim and selector lever knob in black suede. Individual choice of colour for the stitching from the range of Audi exclusive colours. Stitching on the steering wheel rim with specific Audi exclusive seam detail



## | Entertainment

### MMI® radio

- MMI control concept, comprising an electrically extending 5.8-inch colour display, separate MMI control panel and car menu
- CD drive and SDHC memory card reader (up to 32 GB), both MP3 and WMA compatible and AUX-IN connection
- 50-station memory with dynamic station list, FM (VHF) and AM (MW) reception incl. display of information about the current radio station (e. g. title and artist, if available); phase diversity and speed-dependent volume control
- 8 passive loudspeakers front and rear, total output 80 watts

### Digital Audio Broadcasting

in addition to the range of analogue stations, reception of digitally broadcast radio stations<sup>1</sup> according to DAB standard, including DAB+ and DMB audio; display of information accompanying the programme (e. g. artist, title, depending on provision by the respective radio station) as well as additional information in the form of a slide show (e. g. cover, weather); in conjunction with MMI navigation plus with MMI touch, a second DAB tuner continuously searches for alternative reception frequencies of the set radio station; at the same time the station list is updated

### Audi music interface

Portable media players<sup>2</sup> such as Apple iPod/iPhone (music functionality) as well as USB storage media and MP3 players can be connected to the vehicle. In the centre console; operated via MMI, RS multifunction sport leather steering wheel or voice control; part of the connectivity package, navigation package and MMI navigation plus with MMI touch Special Audi Genuine Accessories adapter cables are required for the connection of portable media players or USB storage media. An adapter cable suitable for the respective device can be selected in addition. Further adapter cables are available through Audi Genuine Accessories.

### Audi sound system

impressive sound thanks to 6-channel amplifier with a total output of 180 watts and 10 loudspeakers including centre speaker and subwoofer

### Bang & Olufsen Sound System

fascinating surround sound reproduction with 14 loudspeakers including centre speaker and subwoofer. The 15-channel amplifier has a total output of 705 watts. Reproduction of 5.1 surround sound is possible in conjunction with the optional MMI navigation plus with MMI touch. Exclusive loudspeaker covers with aluminium applications and LED accent lighting on the front woofers as well as dynamic driving noise compensation.

## | Communication

### Audi connect

convenient connection of your vehicle to the internet for the use of Audi connect via an integrated data module with LTE<sup>3</sup>/UMTS support. There is a reader for your SIM card in the surround of the MMI navigation plus with MMI touch.

The following services supported by Audi connect are currently available in your model:

### Mobility & navigation

- point-of-interest (POI) search with voice control
- traffic information online<sup>4</sup>
- picturebook navigation
- fuel prices
- parking information
- navigation with Google Earth™<sup>5</sup> and Google Street View™<sup>5</sup>
- destination entry via myAudi or Google Maps™<sup>5</sup>

### Communication

- Wi-Fi hotspot
- text messages
- access to Facebook
- access to Twitter

### Infotainment

- weather
- Audi music stream
- news online
- travel information

Use of the services supported by Audi connect is possible only with the optional MMI navigation plus with MMI touch equipment and Audi connect. You also require a SIM card with data option and with LTE option<sup>3</sup> to use LTE. The services are available only in conjunction with an existing or separate mobile phone contract and only within the range of the respective the mobile phone network. Additional costs may be incurred when receiving data packets from the internet, depending on the terms of your mobile phone contract, particularly when used abroad. Because of the high data volumes involved, a data flat rate is strongly recommended.

The availability of the services supported by Audi connect varies from country to country. The Audi connect services are always provided for 24 months from vehicle delivery. Following this 24 month period, Audi connect services are extended once free of charge for 12 months. Should you not wish this extension, please notify Audi in writing at the following address:

AUDI AG
Customer Support Germany
85045 Ingolstadt
E-mail: kundenbetreuung@audi.de
Tel.: 0800 28347378423

The city events, train information and flight information service and further services are available to the customer for 12 months. Ask your Audi partner about a subsequent extension of the Audi connect services. Depending on the vehicle model, Audi connect enables access to Facebook, Google and Twitter services. Permanent availability cannot be guaranteed as this is the responsibility of Facebook, Google and Twitter.

Please visit www.audi.com/connect or contact your Audi partner for more detailed information about Audi connect; contact your mobile services provider for information about contract conditions.

Equipment packages
Lights
Design
Steering wheels/controls
Comfort
Infotainment
Assistance systems
Technology/safety
Audi Extended Warranty

## | Assistance systems

### Audi MMI® connect app

The Audi MMI connect app is available for some smartphones<sup>5</sup> and supports the following Audi connect services:

- Audi music stream
- point-of-interest (POI) search with voice control
- destination entry via myAudi or Google Maps™<sup>5</sup>
- traffic information online<sup>4</sup>

### Bluetooth interface

allows hands-free calls to be made in the vehicle using the microphone and – depending on mobile phone compatibility<sup>6</sup> – Bluetooth audio streaming. Bluetooth-capable mobile phones can be connected to the vehicle via the interface.

### Audi phone box<sup>6</sup>

allows phone calls to be made in the vehicle with improved reception quality by placing the mobile phone in the universal phone holder near the front centre armrest; hands-free facility and voice control (telephone); low SAR radiation in the interior by connecting to the external aerial; can be used via radio/navigation systems or the RS multifunction sport leather steering wheel; charging facility via USB port

### Connectivity package

combines the following features:

- Audi music interface
- Bluetooth interface with Bluetooth audio streaming
- preparation for navigation system (navigation function and map data available as retrofit solution from Audi Genuine Accessories)
- additional SDXC card reader (up to 2 TB)

In conjunction with the Audi music interface, the separate AUX-IN connection is omitted.

### Hold assist<sup>7</sup>

holds the vehicle stationary for unlimited periods after stopping in traffic on normal uphill or downhill gradients. The system is activated by push-button and allows the driver to drive away smoothly.

### Parking system plus<sup>7</sup>

acoustic and visual parking system, front and rear, assists with parking and manoeuvring. With selective visual view in the MMI display of the distance to detected objects based on the current steering angle and direction of travel. A white segment indicates a detected obstacle outside the driving path. Red segments represent obstacles in the driving path. The virtual lane display in conjunction with MMI navigation plus with MMI touch additionally provides guidelines at the sides which are calculated in advance on the basis of the current steering angle, thus supporting comfortable entry and exit of parking spaces. Measured by ultrasonic sensors integrated discreetly in the bumpers; can be ordered with reversing camera; activated when reverse gear is selected or via a button on the centre console

### Reversing camera<sup>7</sup>

image of area behind the vehicle shown on the MMI display, with dynamic display modes showing the path calculated based on steering angle; auxiliary lines and guidelines as well as representation of the point at which to apply opposite lock when parallel parking; reversing camera integrated discreetly in the handle strip of the luggage compartment lid; activated when reverse gear is selected or via a button on the centre console

### Cruise control<sup>7</sup>

At speeds from around 30 and above, the system keeps the set speed constant provided that engine power and engine braking effect permit it; operated via separate steering column stalk, set speed displayed in the driver information system

### Audi pre sense basic<sup>7</sup>

automatically initiates preventive occupant protection measures where necessary; these include: tightening the front seat belts, closing the windows and – if ordered – the panoramic glass sunroof; categorises driving situations by networking different vehicle systems

**adaptive cruise control including Audi pre sense front<sup>7</sup>** (part of the assistance package) detects vehicles ahead with the aid of a radar sensor. The distance from the vehicle ahead is kept more or less constant by braking or accelerating. Control range 0 to 200 km/h; including braking to a stop and automated restart at driver’s request possible. 4 distance levels and 3 driving modes (comfort, dynamic and auto). Including Audi pre sense front; operation of adaptive cruise control via separate steering column stalk. Audi pre sense front can be deactivated via the MMI car menu.

### Audi side assist<sup>7</sup>

warns by means of an LED display on the relevant exterior mirror of any situations assessed as critical for lane-changing. 2 radar sensors detect vehicles approaching from behind at the side and measure the distance and the difference in speed. The lane change assistant provides support in the speed range from around 30 km/h. 1-off activation via MMI car menu

### Audi active lane assist<sup>7</sup>

helps you to keep in lane by means of gentle, corrective steering intervention. The lane compliance assistant is triggered when the driver starts to cross detected lane markings without activating an indicator. The system provides support in the speed range from around 60 to 250 km/h. Steering vibration can be adjusted if the driver wishes; camera-based traffic sign recognition is included in conjunction with MMI navigation plus with MMI touch. Including high-beam assist; activated by means of a button on the indicator steering column stalk

### Assistance package<sup>7</sup>

combines the following assistance systems and equipment:

- adaptive cruise control including Audi pre sense front
- Audi active lane assist
- high-beam assist
- light/rain sensor

The systems in the assistance package complement each other and provide mutual assistance. Notes on activation and settings can be found in the description for the respective assistance system.

### Camera-based recognition of traffic signs<sup>7,8</sup>

Traffic sign recognition for overtaking bans and speed limits, including temporary speed limit displays (e.g. above motorways); situation-dependent evaluation in wet conditions and in fog, speed limits that vary depending on the time of day. The traffic sign recognition feature can detect standardised speed limits within the viewing range of the camera within system limits. Supported by Audi connect navigation data, the detected limits are evaluated and automatically displayed in the driver information system. Traffic sign recognition output can be configured via the RS multifunction sport leather steering wheel. Up to 3 traffic signs can be shown exclusively on the display of the instrument cluster or the compulsory sign currently relevant can be shown as an additional display to another system (e.g. digital speed display). The system has purely informative character, there is no manipulation and no warning if the displayed speed is exceeded.

## Equipment

<sup>[1]</sup> Reception depends on digital network availability.

<sup>[2]</sup> Please contact your Audi partner or visit www.audi.com/mp3 for information on compatible media players.

<sup>[3]</sup> For information about the availability and use of LTE support, please contact your Audi partner.

<sup>[4]</sup> The Audi connect service traffic information online is available for many countries. For more information, please contact your Audi partner.

<sup>[5]</sup> Google and the Google logo are registered trademarks of Google Inc.

<sup>[6]</sup> Please contact your Audi partner or visit www.audi.com/bluetooth for information on compatible mobile phones.

<sup>[7]</sup> Please note: The systems work only within system limits. They assist the driver with driving tasks.

However, the driver remains responsible for driving the vehicle and is required to be attentive at all times.

<sup>[8]</sup> Only available for Western Europe.

## | Driving dynamics/brakes

### Audi drive select

features different modes – comfort, auto, dynamic and individual – which allow you to change the vehicle’s characteristics by adapting the power steering assistance, engine and gear changing characteristics, distribution of torque of the quattro drive, exhaust flap control and the settings of other optional equipment

### RS sport suspension

- with dynamically tuned spring/damper combination
- front axle with McPherson struts
- 4-link rear axle with separate spring/damper arrangement

### RS sport suspension plus with Audi magnetic ride

- adaptive damper system, electronically adjustable in 3 stages
- front axle with McPherson struts
- 4-link rear axle with separate spring/damper arrangement
- suspension tuning can be selected in 3 stages via Audi drive select: comfort, auto, dynamic

### quattro®

permanent all-wheel drive with electronically controlled multi-plate clutch on the rear axle as well as wheel-selective torque distribution and Electronic Differential Lock (EDL); distribution of drive forces depending on the driving situation to each individual wheel for precisely controlled, sporty handling; influence on torque distribution via Audi drive select; quattro emblem on the passenger side of the dashboard

### S tronic®

7-speed dual-clutch transmission with electrohydraulic actuation for faster gear changes with virtually no perceptive break in propulsive power. Automatic transmission with D (Drive) and S (Sport) programs; manual control via shift paddles on the RS multifunction sport leather steering wheel or by nudging the selector lever; including hill hold assist

### Progressive steering

enhances the driving dynamics and driving comfort thanks to more direct steering characteristics (e. g. on winding country roads or when turning) and reduced steering effort (e. g. when parking and manoeuvring); impressive driving characteristics thanks to a steering ratio based on the steering angle and speed-sensitive steering assistance, can be set via Audi drive select

### RS brake system

19-inch high-performance brake system, diagonally-split, Antilock Brake System (ABS) with Electronic Brake Force Distribution (EBD), Electronic Stabilisation Control (ESC), hydraulic brake assist, adapted brake booster function; wave brake discs at front in composite design, ventilated and perforated, rear brake discs ventilated; brake callipers painted in gloss black, with RS logo at the front

### Brake callipers, painted in gloss red

for RS brake system, with RS logo at the front

### Ceramic brake\*

19-inch high-performance brake system with carbon-fibre reinforced ceramic brake discs at the front, brake callipers at the front painted in gloss anthracite, with RS logo. Please consult your Audi partner or national Audi website to find out more about the special features of the ceramic brake.

### Secondary collision brake assist

Following an accident, uncontrolled continued vehicle motion is prevented in certain situations. In these cases secondary collisions can be avoided.

### Electromechanical parking brake

includes parking brake function when stationary, drive-off assistance function via automatic release when driving away and maximum deceleration action while driving acting on all 4 wheels

### Top speed increased to 280 km/h

electronically regulated

## | Technology/safety

### Electronic Stabilisation Control (ESC)

with sport mode, can be deactivated in 2 stages; provides better stability at any speed through targeted braking of individual wheels and intervention in the engine management system; networks the ABS, EBD, ASR and EDL with its own sensors and compares the driving data with reference data

### RS exhaust system

dual-branch design with chrome-plated oval tailpipe trims

### RS sport exhaust system

for an enhanced acoustic experience; dual-branch, with chrome-plated oval tailpipe trims

### Recuperation

economises on fuel via brake energy recuperation; kinetic energy is converted into usable electrical energy by increasing the generator voltage when the vehicle is coasting or braking and relieves the generator during subsequent acceleration

Light Design Steering wheels/controls

Comfort Infotainment Assistance systems

### Start-stop system

helps to reduce fuel consumption and CO<sub>2</sub> emissions by automatically switching off the engine when the vehicle is stationary, e.g. at traffic lights. The start process is initiated as soon as the foot brake is released. May be deactivated using a switch at any time

### Airbags

full-size airbags for driver and front passenger as well as knee airbag on the driver side; in conjunction with ISOFIX child seat mounting for the front-passenger seat including deactivation switch for front-passenger airbag

### Side airbags, front, and head airbag system

front side airbags integrated into the seat backrests and an additional head airbag system that deploys along the side windows to protect the front and outer rear seat passengers in the event of a side impact

### Side airbags, rear

to supplement side airbags, front, and head airbag system

### Integrated head restraint system

increases safety and reduces the danger of whiplash. In the event of a rear-end collision, the design of the front seat better restrains the upper torso and provides stronger support for the head than conventional systems.

### ISOFIX child seat mounting and top tether for the outer rear seats

standard mounting for practical attachment of ISOFIX child-seat mounting, including additional fastening point (top tether).

Recommended child seats can be obtained from your Audi partner.

### ISOFIX child seat mounting for the front-passenger seat

with front-passenger airbag deactivation switch, includes electric child-proof lock for the rear doors

Technology/safety Audi Extended Warranty

## | Audi Extended Warranty

### Audi Extended Warranty

The Audi Extended Warranty provides extended risk cover and cost control beyond the first 2 years of the manufacturer’s warranty for a variety of claims. It can be ordered directly and only on purchase of a new car. Choose from nine combinations of service life and mileage. For more information, please contact your Audi partner.

Model	RS 3 Sportback
Engine type	5-cylinder inline petrol engine with direct fuel injection, turbocharging with intercooler
Displacement in cc (valves per cylinder)	2,480 (4)
Max. output <sup>1</sup> in kW at rpm	270/5,550-6,800
Max. torque in Nm at rpm	465/1,625-5,550
<b>Power transmission</b>	
Drive type	quattro® permanent all-wheel drive
Transmission type	7-speed S tronic
<b>Weights/capacities</b>	
Unladen weight <sup>2</sup> in kg	1,595
Gross vehicle weight in kg	2,020
Permissible roof load in kg	75
Fuel tank capacity, approx. in l	55
<b>Performance/consumption<sup>3</sup></b>	
Top speed in km/h	250 <sup>4</sup>
Acceleration 0-100 km/h in s	4.3
Fuel grade	Sulphur-free SuperPlus 98 RON <sup>5</sup>
Fuel consumption <sup>6</sup> in l/100 km	
urban	11.4-11.2
extra-urban	6.5-6.3
combined	8.3-8.1
CO <sub>2</sub> emission <sup>6</sup> in g/km	
urban	268-261
extra-urban	151-147
combined	194-189
Emission standard	EU6

#### Explanatory notes

- The figure given was calculated using the specified measuring procedure (current version of UN-R 85).
- Unladen vehicle weight includes driver (75 kg) and fuel tank 90% full, calculated in accordance with the current version of Reg. (EU) 1230/2012. Optional equipment may increase the car's unladen weight and drag coefficient, whereupon the possible payload limit and the top speed will be reduced accordingly.
- Fuel consumption and CO<sub>2</sub> emission figures given in ranges depend on the tyre/wheel sets used.
- Regulated.
- We recommend using sulphur-free SuperPlus unleaded RON 98 fuel complying with DIN EN 228. If this is not available, use sulphur-free super unleaded RON 95 fuel in accordance with DIN EN 228; power output will be slightly reduced. Unleaded RON 95 fuel with a maximum ethanol content of 10% (E10) can generally be used. Fuel consumption details refer to operation with RON 95 fuel complying with 692/2008/EC.
- The figures given were calculated using the specified measuring procedures. The figures do not refer to one individual vehicle and do not form part of any offer, but rather should be used purely for purposes of comparison between the different vehicle models.

#### Important note

**Special information about the wheels:** Wheels with gloss turned finish as well as polished or partly polished aluminium wheels must not be used in wintry road conditions. For manufacturing reasons, the rim surface does not have sufficient corrosion protection for such use and can be damaged permanently by road salt or similar.

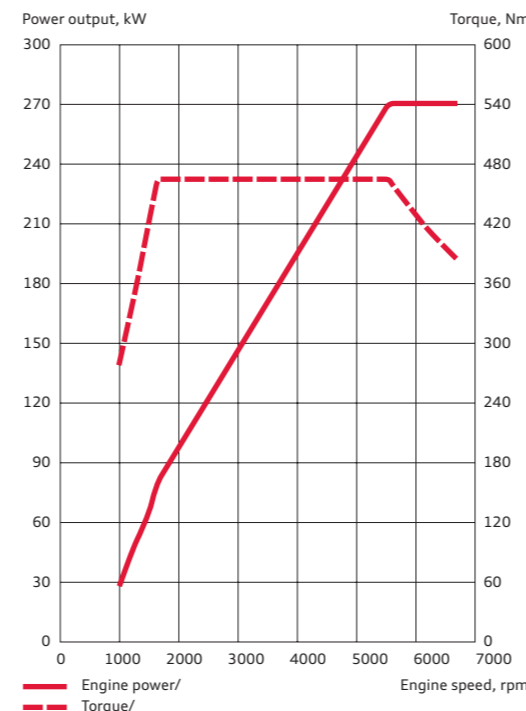

#### Audi RS 3 Sportback

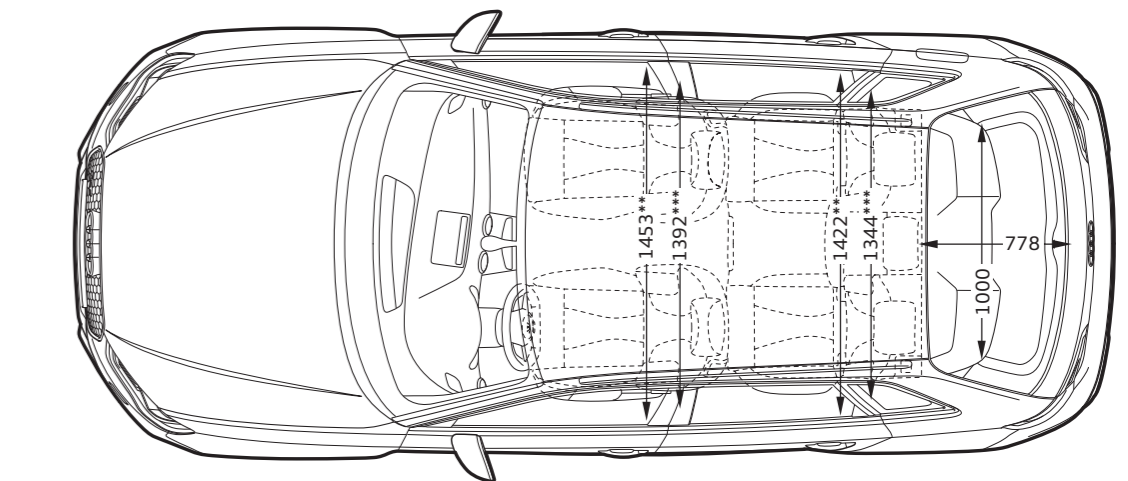
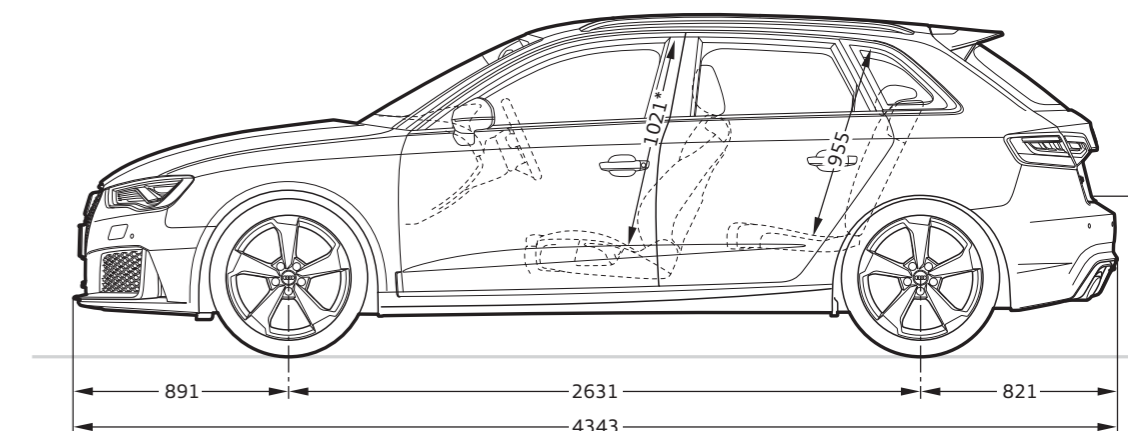
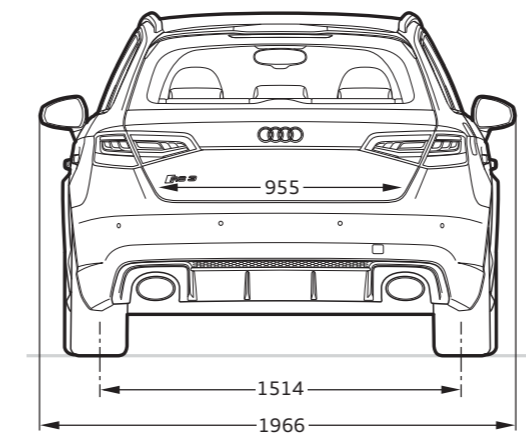
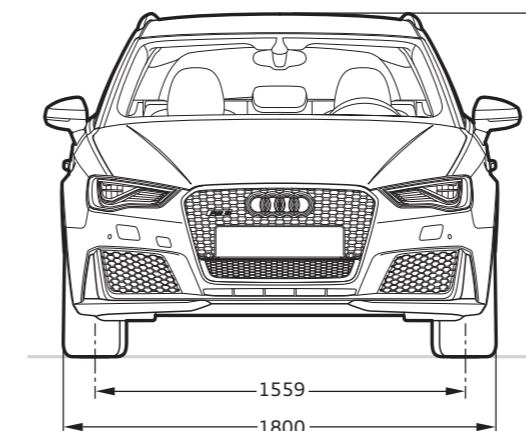











#### Dimensions in millimetres.

Dimensions are for unladen vehicle weight.

Luggage compartment volume: 340/1,180 l (second value with the rear seat backrest folded down and vehicle loaded up to roof height).









Turning circle approx. 10.9 m. \* Maximum headroom. \*\* Elbow room width. \*\*\* Shoulder room width.

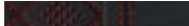

<b>Solid paint finish</b>	<b>36</b>
 Nardo grey	<input type="checkbox"/>
<b>Metallic paint finishes</b>	<b>37</b>
 Glacier white, metallic	<input checked="" type="checkbox"/>
 Floret silver, metallic	<input checked="" type="checkbox"/>
 Catalunya red, metallic	<input checked="" type="checkbox"/>
 Mythos black, metallic	<input checked="" type="checkbox"/>
<b>Pearl effect paint finishes</b>	<b>37</b>
 Daytona grey, pearl effect	<input checked="" type="checkbox"/>
 Sepang blue, pearl effect	<input checked="" type="checkbox"/>
<b>Crystal effect paint finish</b>	<b>37</b>
 Panther black, crystal effect	<input checked="" type="checkbox"/>
<b>Customised paint finishes</b>	<b>37</b>
 Audi exclusive customised paint finishes	<input checked="" type="checkbox"/>
<b>Wheels/tyres</b>	<b>39</b>
 19" cast aluminium wheels in 5-arm rotor design	<input type="checkbox"/>
 19" cast aluminium wheels in 5-arm rotor design in matt titanium look, gloss turned finish <sup>1</sup>	<input checked="" type="checkbox"/>
 19" cast aluminium wheels in 5-arm rotor design in titanium look, gloss turned finish <sup>1</sup>	<input checked="" type="checkbox"/>
 19" cast aluminium wheels in 5-arm rotor design in gloss anthracite black, gloss turned finish <sup>1</sup>	<input checked="" type="checkbox"/>
 19" cast aluminium winter wheels in 5-arm rotor design	<input checked="" type="checkbox"/>

Standard equipment  Optional equipment

Country-specific variations possible. Please find out from your local Audi partner which equipment is standard and what optional equipment is available in your country.

More detailed descriptions of a selection of items from the equipment range can be found from page 36 onwards.

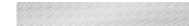
Anti-theft wheel bolts	<input checked="" type="checkbox"/>
Tyre repair kit	<input type="checkbox"/>
Tyre pressure loss indicator	<input checked="" type="checkbox"/>
Vehicle tool kit	<input type="checkbox"/>
Vehicle jack	<input checked="" type="checkbox"/>
<b>Seats</b>	<b>40</b>
Sport seats, front	<input type="checkbox"/>
RS sport seats, front	<input checked="" type="checkbox"/>
RS bucket seats, front	<input checked="" type="checkbox"/>
<b>Seat upholstery for sport seats, front</b>	<b>41</b>
 Fine Nappa leather, black with contrasting stitching in grey	<input type="checkbox"/>
 Fine Nappa leather, black with contrasting stitching in red	<input type="checkbox"/>
 Audi exclusive leather upholstery and trim <sup>2</sup>	<input checked="" type="checkbox"/>
<b>Seat upholstery for RS sport seats, front</b>	<b>41</b>
 Fine Nappa leather, black with diamond pattern in grey	<input checked="" type="checkbox"/>
 Fine Nappa leather, black with diamond pattern in red	<input checked="" type="checkbox"/>
 Fine Nappa leather, lunar silver with diamond pattern in grey	<input checked="" type="checkbox"/>
 Audi exclusive leather upholstery and trim <sup>2</sup>	<input checked="" type="checkbox"/>
<b>Seat upholstery for RS bucket seats, front</b>	<b>41</b>
 Fine Nappa leather, black with contrasting stitching in grey	<input checked="" type="checkbox"/>
 Fine Nappa leather, black with contrasting stitching in red	<input checked="" type="checkbox"/>
<b>Leather upholstery and trim</b>	<b>42</b>
Fine Nappa leather upholstery and trim with contrasting stitching	<input type="checkbox"/>
Fine Nappa leather upholstery and trim with diamond pattern	<input checked="" type="checkbox"/>
Audi exclusive fine Nappa leather upholstery and trim <sup>2</sup>	<input checked="" type="checkbox"/>

<b>Leather packages</b>	<b>42</b>
RS design package	<input checked="" type="checkbox"/>
Extended interior elements mono.pur	<input checked="" type="checkbox"/>
Audi exclusive extended leather upholstery and trim <sup>2</sup>	<input checked="" type="checkbox"/>
<b>Seat comfort</b>	<b>42</b>
Driver seat, electrically adjustable	<input checked="" type="checkbox"/>
Front seats, electrically adjustable	<input checked="" type="checkbox"/>
4-way lumbar support for the front seats	<input checked="" type="checkbox"/>
Seat heating, front	<input checked="" type="checkbox"/>
Centre armrest, front	<input type="checkbox"/>
<b>Seats in the rear</b>	<b>42</b>
Rear seat backrest, folding	<input type="checkbox"/>
<b>Headlining</b>	<b>42</b>
Headlining in cloth	<input type="checkbox"/>
<b>Inlays</b>	<b>43</b>
 3D-design "Black"	<input type="checkbox"/>
 Aluminium Race	<input checked="" type="checkbox"/>
 Carbon	<input checked="" type="checkbox"/>
 Inlays painted in Audi exclusive colour <sup>2</sup>	<input checked="" type="checkbox"/>
<b>Equipment packages</b>	<b>44</b>
Convenience package	<input checked="" type="checkbox"/>
<b>Headlights/interior lighting</b>	<b>44</b>
Xenon plus	<input type="checkbox"/>
adaptive light	<input checked="" type="checkbox"/>
Variable headlight range control	<input checked="" type="checkbox"/>
LED headlights	<input checked="" type="checkbox"/>
Headlight cleaning system	<input type="checkbox"/>
High-beam assist	<input checked="" type="checkbox"/>
Light/rain sensor	<input checked="" type="checkbox"/>

Adaptive brake light	<input type="checkbox"/>
LED rear lights	<input type="checkbox"/>
Lighting package	<input checked="" type="checkbox"/>
Vanity mirror, illuminated	<input type="checkbox"/>
<b>Exterior design</b>	<b>45</b>
Model name/logo	<input type="checkbox"/>
Audi Singleframe	<input type="checkbox"/>
RS bumpers	<input type="checkbox"/>
Wheel house extensions	<input type="checkbox"/>
Sill extensions	<input type="checkbox"/>
Trim strips	<input type="checkbox"/>
Roof rails	<input checked="" type="checkbox"/>
RS roof edge spoiler	<input type="checkbox"/>
Engine cover with carbon trim	<input checked="" type="checkbox"/>
Matt aluminium styling package including quattro® logo	<input checked="" type="checkbox"/>
Gloss black styling package including quattro® logo	<input checked="" type="checkbox"/>
<b>Interior design</b>	<b>45</b>
Aluminium look in the interior	<input type="checkbox"/>
Floor mats, front and rear, in black	<input type="checkbox"/>
Audi exclusive floor mats with RS 3 logo <sup>2</sup>	<input checked="" type="checkbox"/>
Pedals and footrest in stainless steel	<input type="checkbox"/>
Door sill trims with aluminium inlays	<input type="checkbox"/>
<b>Steering wheels/controls</b>	<b>45</b>
RS multifunction sport leather steering wheel in 3-spoke design, flattened at the bottom	<input type="checkbox"/>
RS selector lever knob in leather	<input type="checkbox"/>
Audi exclusive leather controls <sup>2</sup>	<input checked="" type="checkbox"/>
Audi exclusive controls in black suede <sup>2</sup>	<input checked="" type="checkbox"/>

<sup>1</sup> Please note the special information relating to wheels on page 52.

<sup>2</sup> For information on when this feature will be available, please contact your Audi partner.

<b>Mirrors</b>	<b>46</b>
Exterior mirrors with integrated LED indicator	<input type="checkbox"/>
Exterior mirrors, additionally heated	<input checked="" type="checkbox"/>
Exterior mirrors, additionally heated and electrically folding	<input checked="" type="checkbox"/>
Exterior mirrors, additionally heated, electrically folding and automatically dimming on the driver side	<input checked="" type="checkbox"/>
Exterior mirror housings in matt aluminium look	<input type="checkbox"/>
Exterior mirror housings painted in body colour	<input checked="" type="checkbox"/>
Exterior mirror housings in gloss black	<input checked="" type="checkbox"/>
Interior mirror, manually dimming	<input type="checkbox"/>
Interior mirror, automatically dimming	<input checked="" type="checkbox"/>
<b>Roof system</b>	<b>46</b>
Panoramic glass sunroof	<input checked="" type="checkbox"/>
<b>Glazing</b>	<b>46</b>
Heat-insulating glass, tinted green	<input type="checkbox"/>
Acoustic windscreen	<input type="checkbox"/>
Dark-tinted windows (privacy glazing)	<input checked="" type="checkbox"/>
Sun visors, hinged and swivel-mounted	<input type="checkbox"/>
<b>Climate control</b>	<b>46</b>
Deluxe automatic air conditioning	<input type="checkbox"/>
<b>Closing systems</b>	<b>46</b>
Remote control key with RS emblem	<input type="checkbox"/>
Engine start-stop button with red ring	<input checked="" type="checkbox"/>
Convenience key	<input checked="" type="checkbox"/>
Electronic immobiliser	<input type="checkbox"/>
Anti-theft alarm	<input type="checkbox"/>
Preparation for tracking system	<input checked="" type="checkbox"/>

Standard equipment     Optional equipment

<sup>1</sup> Only with Audi active lane assist in conjunction with MMI navigation plus with MMI touch.

<sup>2</sup> For information on when this feature will be available, please contact your Audi partner.

Country-specific variations possible. Please find out from your local Audi partner which equipment is standard and what optional equipment is available in your country.

More detailed descriptions of a selection of items from the equipment range can be found from page 36 onwards.

<b>Storage/transport</b>	<b>47</b>
Storage compartments	<input type="checkbox"/>
Storage and luggage compartment package	<input type="checkbox"/>
Luggage compartment cover, detachable	<input type="checkbox"/>
Through-loading facility	<input checked="" type="checkbox"/>
Ski/snowboard bag	<input checked="" type="checkbox"/>
Lashing points, set of 4	<input type="checkbox"/>
Reversible mat	<input checked="" type="checkbox"/>
Mobile phone/key holder	<input checked="" type="checkbox"/>
Cigarette lighter and ashtray	<input checked="" type="checkbox"/>
<b>MMI®/navigation</b>	<b>47</b>
RS instrument cluster	<input type="checkbox"/>
Driver information system with colour display	<input type="checkbox"/>
Navigation package	<input checked="" type="checkbox"/>
MMI® navigation plus with MMI touch	<input checked="" type="checkbox"/>
<b>Entertainment</b>	<b>48</b>
MMI® radio	<input type="checkbox"/>
Digital Audio Broadcasting	<input checked="" type="checkbox"/>
Audi music interface	<input checked="" type="checkbox"/>
Audi sound system	<input checked="" type="checkbox"/>
Bang & Olufsen Sound System	<input checked="" type="checkbox"/>
<b>Communication</b>	<b>48</b>
Audi connect	<input checked="" type="checkbox"/>
Audi MMI® connect app	<input checked="" type="checkbox"/>
Bluetooth interface	<input checked="" type="checkbox"/>
Audi phone box	<input checked="" type="checkbox"/>
Connectivity package	<input checked="" type="checkbox"/>
<b>Assistance systems</b>	<b>49</b>
Hold assist	<input checked="" type="checkbox"/>
Parking system plus	<input checked="" type="checkbox"/>

Reversing camera	<input checked="" type="checkbox"/>
Cruise control	<input checked="" type="checkbox"/>
Audi pre sense basic	<input checked="" type="checkbox"/>
adaptive cruise control including Audi pre sense front	<input checked="" type="checkbox"/>
Audi side assist	<input checked="" type="checkbox"/>
Audi active lane assist	<input checked="" type="checkbox"/>
Assistance package	<input checked="" type="checkbox"/>
Camera-based recognition of traffic signs <sup>1</sup>	<input checked="" type="checkbox"/>
<b>Driving dynamics/brakes</b>	<b>50</b>
Audi drive select	<input type="checkbox"/>
RS sport suspension	<input type="checkbox"/>
RS sport suspension plus with Audi magnetic ride	<input checked="" type="checkbox"/>
quattro®	<input type="checkbox"/>
S tronic®	<input type="checkbox"/>
Progressive steering	<input type="checkbox"/>
RS brake system	<input type="checkbox"/>
Brake callipers, painted in gloss black	<input type="checkbox"/>
Brake callipers, painted in gloss red	<input checked="" type="checkbox"/>
Ceramic brake <sup>2</sup>	<input checked="" type="checkbox"/>
Secondary collision brake assist	<input type="checkbox"/>
Electromechanical parking brake	<input type="checkbox"/>
Top speed increased to 280 km/h	<input checked="" type="checkbox"/>
<b>Technology/safety</b>	<b>51</b>
Antilock Brake System (ABS) with Electronic Brake Force Distribution (EBD)	<input type="checkbox"/>
Anti-Slip Regulation (ASR)	<input type="checkbox"/>
Electronic Differential Lock (EDL)	<input type="checkbox"/>
Electronic Stabilisation Control (ESC)	<input type="checkbox"/>
RS exhaust system	<input type="checkbox"/>
RS sport exhaust system	<input checked="" type="checkbox"/>
Recuperation	<input type="checkbox"/>

Start-stop system	<input type="checkbox"/>
Airbags	<input type="checkbox"/>
Side airbags, front, and head airbag system	<input type="checkbox"/>
Side airbags, rear	<input checked="" type="checkbox"/>
Side impact protection	<input type="checkbox"/>
Integrated head restraint system	<input type="checkbox"/>
Seat belts	<input type="checkbox"/>
Seat belt reminder	<input type="checkbox"/>
ISOFIX child seat mounting and top tether for the outer rear seats	<input type="checkbox"/>
ISOFIX child seat mounting for the front-passenger seat	<input checked="" type="checkbox"/>
First-aid kit	<input type="checkbox"/>
Warning triangle	<input checked="" type="checkbox"/>
<b>Audi Extended Warranty</b>	<b>51</b>
Audi Extended Warranty	<input checked="" type="checkbox"/>

Equipment for the Audi RS 3 Sportback illustrated (p. 4–19):

Paint finish: Catalunya red, metallic

Wheels: cast aluminium wheels in 5-arm rotor design in matt titanium look, gloss turned finish



Seats/seat upholstery: RS sport seats, front, in fine Nappa leather, black with diamond pattern in red

Inlays: carbon

Further equipment: RS design package

#### Classifications of tyre parameters

The table shows the range of fuel efficiency, wet grip and exterior noise emission classes for the different tyre sizes of the Audi RS 3 Sportback.

	<b>Tyre size</b>	<b>Fuel efficiency class</b>	<b>Wet grip class</b>	<b>Exterior noise emission class</b>
Summer tyres	235/35 R 19	E	A	72 
	255/30 R 19	E	A	73 
Winter tyres	235/35 R 19	E	B	72 

It is not possible to order a specific tyre. Ask your Audi partner about the range of tyres available in your country.



## Responsibility

Living up to our responsibilities is a principle that is firmly anchored in Audi strategy. Alongside commercial success and international competitiveness, our responsibility toward company employees and society as a whole is a key consideration, as is protecting the environment and conserving resources. And what is true in the details – our catalogues are printed on FSC-certified paper – also holds in general: Audi develops cars that are not only sporty and emotive but also ever more efficient. In the long run, Audi wants its products to allow CO<sub>2</sub>-neutral

mobility. Seeing to it that production in Audi plants gradually becomes CO<sub>2</sub>-neutral is another aspect of our comprehensive approach. Audi is also committed to society – particularly in the fields of education, technology and social projects. At Audi, sustainability is closely linked with how we see the future: the Audi Urban Future Initiative sees Audi working with international experts to get to the root of future urban challenges and trends in mobility.

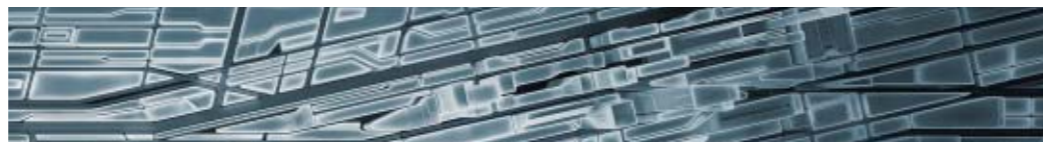

# Discover the world of Audi.

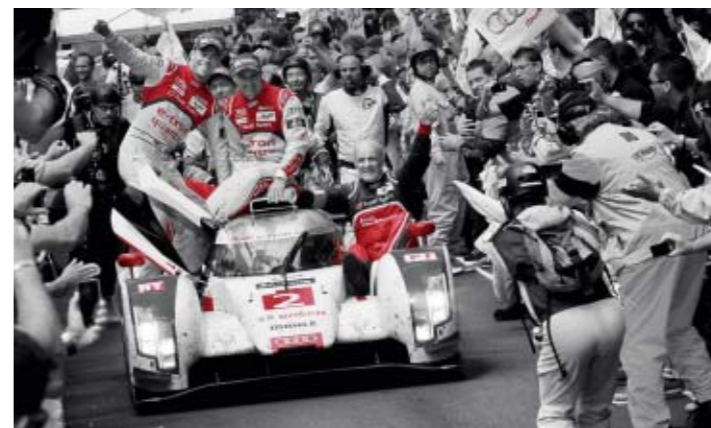

## The Audi experience

The fascination of Audi can be experienced in many different ways. Audi City Berlin, Audi City London and Audi City Beijing, for example, give you digital access to all models at their actual size and in real time. And of course it is always worth visiting one of the major motor shows. This is where Audi always presents its new models and invites you to take a look at how the future is being shaped with "Vorsprung durch Technik". Anyone interested in seeing how Audi is already putting this into practice will find fascinating insight in the "Vorsprung durch Technik" online special at [www.audi.com](http://www.audi.com). But a look back can also be rewarding: at the Audi museum mobile in Ingolstadt, history and high-tech go hand in hand. A total of 130 historic exhibits and state-of-the-art

forms of presentation make for a thrilling symbiosis. Plus, Audi driving experience allows you to live the excitement and countless possibilities of current Audi models. Here, pure driving enjoyment is combined with valuable learning effects. This is ensured by a team of specially trained and highly qualified instructors who provide practical tips to help you optimise your driving skills. All this can now also be enjoyed at the recently opened Audi driving experience center in Neuburg, near Ingolstadt. Facilities here include a circuit of up to 3.4 kilometres that features challenging combinations of bends, a 30,000 m<sup>2</sup> dynamic driving area and an offroad section where Q models can be put through their paces.



## Team spirit

Motorsport is a driving force behind the brand. For years Audi has been among the champions in various racing series, for instance the 24 Hours of Le Mans or the DTM German Touring Car Masters. The values that are crucial in many different areas of sport are also central ones for Audi: precision, passion and technology. No coincidence then that Audi has been sponsoring sporting events for

many years. In the world of winter sports, for example, Audi has been the main sponsor of the German Ski Association (DSV) for almost three decades and has also partnered 16 other national alpine teams. In football, we support national and international teams. And Audi is also a partner for the German Olympic Sports Confederation.

Choosing an Audi means choosing a brand that offers more. More individuality. More exclusivity. More fascination.

## www.audi.com

Information on all the topics mentioned above can be found on our website: [www.audi.com](http://www.audi.com).



[www.audi.com](http://www.audi.com)



[configurator.audi.com](http://configurator.audi.com)



[www.audi.com/vorsprung-durch-technik](http://www.audi.com/vorsprung-durch-technik)



[www.audi.com/driving](http://www.audi.com/driving)



[www.audi.com/cr](http://www.audi.com/cr)



**quattro GmbH**  
85045 Ingolstadt  
www.audi.com  
Valid from  
March 2015  
Printed in Germany  
558/1131.00.18



The models and equipment versions illustrated and described in this brochure and some of the services listed are not available in all countries. Some of the cars illustrated are equipped with optional features for which an extra charge is made. Details concerning the delivery specifications, appearance, performance, dimensions and weights, fuel consumption and running costs of the vehicles were correct to the best of our knowledge at the time of going to press. Deviations from the colours and shapes shown in the illustrations may occur. No liability is accepted for errors and printing errors. The right to introduce modifications is reserved. Not to be reproduced, including in part, without the written approval of AUDI AG.

This brochure is printed on paper made from pulp bleached without the use of chlorine.