



A3 | S3



The new Audi A3.
Further ahead.



The figures for fuel consumption and CO₂ emissions can be found from page 110 onwards.

The new Audi A3 Sportback

Further ahead can be measured in kilometres. Or in ideas.

The figures for fuel consumption and CO₂ emissions figures can be found from page 110 onwards.



The basic idea: functionality made beautiful.

Progressive design that speaks a unique language. Innovative technologies that emphasise dynamism and efficiency. And an interior that impressively combines aesthetics with intuitive functionality. Our lead can be discovered in many facets. In the new Audi A3 Sportback.

Experience how good ideas move you forward. Further ahead.

Striking and muscular.

The slim side of the new Audi A3 Sportback is defined by the striking tornado line along the edge of the window and the dynamic line above the sills. Taut, sculptural areas where light meets shadow give the vehicle a compact and muscular look.





The dynamic roof contour of the new Audi A3 Sportback is designed to emphasise the car's sporty character. Despite its lightness, the vehicle's powerful rear gives it a confident stance. The combination of a longer wheelbase and short overhangs makes the new Audi A3 Sportback look longer and conveys a sense of elegant sportiness.



One touch faster.

Quicker gear changes made simple. Thanks to the optional S tronic 7-speed dual-clutch transmission with virtually no break in propulsive power, available for many models. And on request, even more individual driving dynamics thanks to Audi drive select and suspension with damper control.

The new Audi A3

Progress can be fascinating.
Or absolutely thrilling.



Opt for thrilling.

Sportiness all along the line. The design of the new Audi A3 sets your pulse racing even when stationary. With details that draw a distinction at first sight. Such as sporty proportions, dynamic lines, and extra-large doors.



The figures for fuel consumption and CO₂ emissions figures can be found from page 110 onwards.

Sharper and more dynamic: the new Audi A3 has an athletic appearance. Horizontal double chrome struts in the redesigned Audi Singleframe signal self-assurance all along the line. The rear also reflects dynamism. With new three-dimensional rear lights, striking lines of shadow and a wider diffuser.



The new Audi A3 Saloon

You can either follow a new line.
Or define it.





Saloon redefined.

Dynamic contours. Taut muscular areas. Coupé-like lightness. The new Audi A3 Saloon casts a progressive light on the term saloon. Sporty through and through. Elegant and confident. Ready to rediscover the world.

^^
^^
^^
^^

A new perspective: compact saloon with coupé character. Wide and low. Precise lines, emphasis on three-dimensional design. The low, flowing line of the roof dome conveys pure dynamism. Strongly accentuated wings with shaped wheel arches frame the optional up to 19-inch cast aluminium wheels.



Power exuded by the singleframe with double chrome struts. Aerodynamic air inlets. Optional full-LED headlights. Perfectly integrated into the three-dimensional body line. Add to that a striking trailing edge and elegantly rising rear lights.

The new Audi A3 Saloon: progressive sportiness.



The figures for fuel consumption and CO₂ emissions figures can be found from page 114 onwards.



Freedom can exist in a special moment.
Or simply in the idea of it.

The new Audi A3 Cabriolet

Inspiring freedom.

Fascination at first sight. Deep lines. Dynamic proportions. Combined in elegant lightness. With fully automatic cloth hood as standard and acoustic hood on request. The new Audi A3 Cabriolet. Sporty. Inspiring. Open for new ideas. And boundless freedom.



New perspectives. Infinitely thrilling. Opened up by the standard fully automatic cloth hood. Even while driving at speeds of up to 50 km/h. Particularly quiet with the optional high-quality acoustic hood. Or all about sound. With the optional Bang & Olufsen Sound System with 13 loudspeakers and a total output of 625 watts.





Technology can be improved.
Or taken to a new level.

The new high lights

The figures for fuel consumption and CO₂ emissions figures can be found from page 110 onwards.





More than a look ahead.

The future in sight. Every day. Clearly visible from the driver seat. With Audi virtual cockpit, the optional, fully digital instrument cluster. Taking function and design to a new level. A host of information the driver needs clearly in sight. With numerous view options on the high-resolution 12.3-inch display.

Razor-sharp, brilliant and rich in contrast.



The familiar world of your smartphone in the MMI menu: with the optional Audi smartphone interface¹. Shown on the high-resolution MMI colour display. Reach your destination without any detours. Thanks to the enhanced MMI control concept and optional MMI navigation plus with MMI touch. Intuitive operation due to fewer buttons and destination entry without sub-menus. Touch-sensitive entry field with recognition of handwriting and touch gestures. Also for the services supported by Audi connect².

The future becomes more complex, and easier.



The figures for fuel consumption and CO₂ emissions figures can be found from page 110 onwards. ¹The smartphone manufacturers are responsible for all content and functions displayed in the vehicle via the Audi smartphone interface. ²For legal information and notes on use, please see page 118.



High quality and innovative design can be found in every detail. The horizontal architecture of the dashboard emphasises the size of the interior, 3D inlays¹ seem to embrace the driver. The optional inlays in matt brushed aluminium light design² and the air vents in jet design further accentuate the stylish interior.

¹Standard in conjunction with A3 design. ²Standard in conjunction with Audi design selection. The figures for fuel consumption and CO₂ emissions figures can be found from page 110 onwards.



Comfortable seats and a generous amount of space characterise the rear. The rear bench seat can be split-folded 40:60, and the optional seat bench can be split-folded 40:20:40¹. With the rear seat bench folded down completely, you have up to 1,100 litres of luggage compartment volume² in the new Audi A3 or even up to 1,220 litres in the new Audi A3 Sportback.

The figures for fuel consumption and CO₂ emissions figures can be found from page 110 onwards. ¹Not available for A3 Cabriolet.
²Technical specifications refer to a basic vehicle without country-specific settings and the selected optional equipment.

Progressivity in a new light.

Their crystal-clear shine ensures bright, homogeneous illumination of the road. Selective fading out of other vehicles. Curve light function and automatic dynamic headlight range control. Possible thanks to precise, individually controllable light-emitting diodes in the optional Audi Matrix LED headlights. Dynamic indicator included. Also at the rear.

The figures for fuel consumption and CO₂ emissions figures can be found from page 110 onwards.



The next step towards piloted driving.

More convenience and additional safety. The comprehensive, redeveloped driver assistance systems¹ will take care of that. Upon request in any Audi A3/S3. Take the cross traffic assist at the rear, which alerts the driver to the risk of a possible collision when leaving a parking space. In particularly dangerous situations, the emergency assist can help to keep the vehicle in lane if the driver becomes unresponsive and to brake the vehicle to a standstill if necessary. In conjunction with S tronic, adaptive cruise control Stop&Go keeps the vehicle at a constant distance from the vehicle in front. And the congestion assist takes over the steering work at speeds of up to 65 km/h, thus making life easier in stop-and-go traffic.



The figures for fuel consumption and CO₂ emissions figures can be found from page 110 onwards. ¹Please note: The systems work only within system limits and assist the driver. However, the driver remains responsible for driving the vehicle and is required to be attentive at all times.



The heart of getting you ahead.

Whether it's the 1.0-litre 3-cylinder TFSI or the powerful 2.0-litre 4-cylinder TFSI: Audi's latest engine technologies allow for an outstandingly agile yet highly efficient ride. The 2.0-litre 4-cylinder TFSI engine in the new Audi A3 deploys its power with 140 kW. Ideal for a fuel-efficient, moderate driving style without compromising sportiness. The new Audi A3's 228-kW engine enables the car to sprint from 0 to 100 km/h in 4.5 seconds. The combined CO₂ emissions start at 146 g/km and 400 Nm of torque ensure spontaneous power delivery.

The figures for fuel consumption and CO₂ emissions figures can be found from page 110 onwards.





The new Audi S3.
A faster thrill.



The new Audi S3 Sportback and the new Audi S3

Being in the lead can be
your goal.
Or your starting point.

Ahead as standard.

More power, more sportiness, more driving enjoyment. Brought to the road by two exceptional vehicles: the new Audi S3 and the new Audi S3 Sportback. The choice is yours.

Choose your own personal starting point that will put you further ahead from the word go.



Pure sportiness.

Exterior mirrors in aluminium look. Singleframe with S emblem and double chrome struts. On the new Audi S3 Sportback the details alone point to pure sportiness. The same goes for the side sills that impressively emphasise the shape and lines of the front and rear aprons.



Striking rear diffuser with an S-specific dual-branch exhaust system. Two oval tailpipe trims right and left accentuate the vehicle's impressive width. On request with fascinating 19-inch cast aluminium wheels. In addition, the distinctive roof edge spoiler makes the Audi S3 hug the road even more.



Everything your athlete's heart desires.



A top athlete takes the lead.

The standard full-LED headlights, the S design of the side air inlets as well as the ventilated 17-inch brakes with sensational black or even red painted brake callipers visually underline the dynamism of the new Audi S3.





Regardless of the direction,
you get ahead faster with the new Audi S3.





Dynamism can

test the limits. Or open up new perspectives.

The new Audi S3 and the new Audi

Saloon S3 Cabriolet



The saloon with the S factor.

More powerful. Sportier. Fascinating at first sight. With a unique design. S-typical. Rear diffuser and dual-branch exhaust system. Oval exhaust tailpipes. An appearance that raises expectations. And satisfies them. Inspirational. The new Audi S3 Saloon.



The new Audi S3 Saloon knows only one direction.
Ahead. Ahead in remarkably sporty style.



S for stability.

The quattro drive confidently distributes power to all four wheels, and promises excellent directional stability and improved traction. In addition, thanks to Audi drive select you can adjust the character of your vehicle to match your own driving style.

Aided by the optional Audi magnetic ride – dynamics or a sporty yet comfortable ride.





Superb sporty atmosphere. Discernible on the optional front sport seats. Surrounded by characteristic S features. On request with a multifunction sport leather steering wheel, flattened at the bottom and inlays in matt brushed aluminium, design light. Pedals in brushed stainless steel. Sporty can be this exclusive. Or vice versa.

The figures for fuel consumption and CO₂ emissions figures can be found from page 114 onwards.



Dynamism that you can feel and see. One example is the Audi Singleframe with S-specific chrome-plated double struts. Another the optional up to 19-inch cast aluminium wheels. S-characteristic. Worthy of performance.

The figures for fuel consumption and CO₂ emissions figures can be found from page 114 onwards.





Freedom intensified.

Magnificent view. With an expanded panorama in 18 seconds. Thanks to the standard fully automatic cloth hood. Even while driving at speeds of up to 50 km/h. Enjoy life with the new Audi S3 Cabriolet.

Unrestrained. Intensive. In top form.



**Desire freedom
with 228 kW.**

The new Audi A3 Sportback g-tron

Innovations can change everyday life. Or the world.

The new Audi A3 Sportback g-tron with bivalent drive harnessing innovative TFSI technology with TCNG modification. In the pure CNG operation the new Audi A3 Sportback 1.4 TFSI g-tron covers the impressive distance of 400 km with low fuel consumption. In total, its fuel range¹ is around 1,300 km.



The figures for fuel consumption and CO₂ emissions figures can be found from page 112 onwards. ¹The specified range may vary due to deploying additional consumers, air conditioning, outside temperature, driving speed, load/additional equipment, wheel/tyre size, topography, driving style and the traffic situation.



More versatile. A quick look at your options.

The new Audi A3 – an exceptional vehicle whose diverse range of high-quality equipment will impress you. As will many other optional highlights – let yourself be inspired.

- 01 _ Bang & Olufsen Sound System
- 02 _ Audi exclusive customised paint finish in solar orange and Audi exclusive titanium black styling package¹
- 03 _ Acoustic hood in black, grey or garnet red
- 04 _ Assist package with the following assistance systems: adaptive cruise control (Stop&Go with S tronic), Audi active lane assist, congestion assist and emergency assist (only S tronic), Audi pre sense, front including recognition of pedestrians, recognition of traffic signs, high-beam assist and parking system plus
- 05 _ Audi phone box with wireless charging (Qi standard)





^^
^^
^^ 01 | 02 | 03 | 04 | 05

- 01 _ Lighting package
- 02 _ Deluxe automatic air conditioning
- 03 _ Multifunction leather steering wheel in 3-spoke design
- 04 _ Gear lever knob in leather
- 05 _ Illuminated door sill trims and inlays
- 06 _ Rear seat backrest, folding
- 07 _ S sport seat, front in fine Nappa leather, black with contrasting stitching in rock grey with diamond pattern

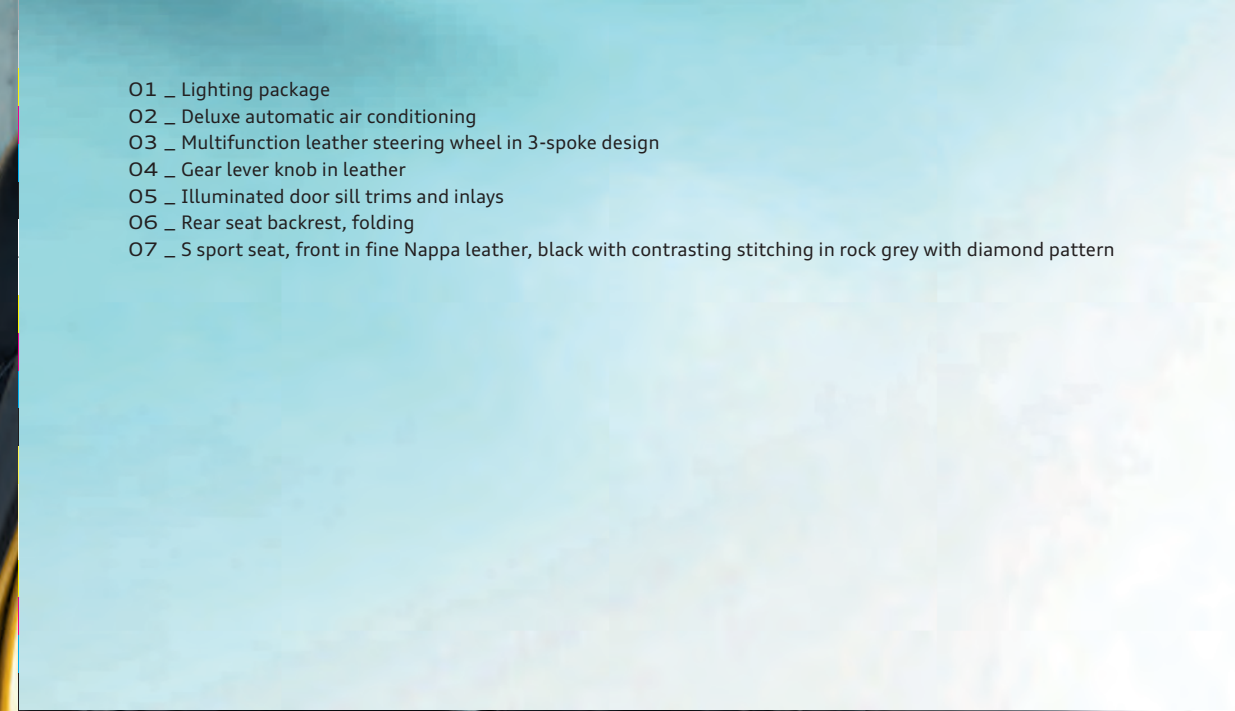

^^
^^
^^ 07



^^
^^
^^ 06



More exceptional. With A3 design.

In an Audi A3, there is plenty of room for your ideas to unfold. With the A3 design line, for example, you can integrate striking highlights that reflect your personality.

^^
^^
^^ 01 | 02 | 03

- 01 _ Gloss package
- 02 _ Air inlet grilles with L-shaped chrome strut
- 03 _ 17" cast aluminium wheels in 10-spoke turbine design
- 04 _ 3D-design "Optic" inlay in titanium grey
- 05 _ Standard seat, front, seat upholstery in regatta cloth/artificial leather
- 06 _ Aluminium look in the interior
- 07 _ Lighting package
- 08 _ Gear or selector lever knob in leather
- 09 _ Multifunction sport leather steering wheel in 3-spoke design

^^
^^
^^ 04

^^
^^
^^ 05 | 06 | 07 | 08 | 09

Make an exceptional car even more exceptional. And do so in style – Audi design selection offers you an aesthetic pre-selection of special material colours for the interior. The Audi design selection in cosmos blue or optionally in amaretto brown – both designs come with attractive contrasting stitching in the interior.

^^
^^
^^ 01

- 01 _ sport seats, front in plenum cloth/leather, black/cosmos blue with contrasting stitching in blue
- 02 _ Illuminated door sill trims in aluminium
- 03 _ Matt brushed aluminium, design light inlays
- 04 _ Leather package, black with contrasting stitching in blue – also on the armrests in the doors and lower centre console
- 05 _ Floor mats with contrasting stitching

^^
^^
^^ 02

^^
^^
^^ 03 | 04 | 05

More sporty. With A3 sport.

Show your sporty side with the A3 sport equipment version – all along the line. With details that emphasise the temperament of your Audi A3 in impressive style and highlight powerful performance at first sight.



^^
^^
^^ 01 | 02



^^
^^
^^ 03 | 04 | 05 | 06

- 01 _ Air inlet grilles with vertical struts in aluminium look
- 02 _ 17" cast aluminium wheels in 5-arm design
- 03 _ Inlay in aluminium mistral
- 04 _ S sport seats, front, S line seat upholstery in fine Nappa leather, black with contrasting stitching in rock grey – optionally available in conjunction with S line sport package
- 05 _ Gear or selector lever knob in leather
- 06 _ Sport suspension and Audi drive select
- 07 _ Chrome-plated trims for exhaust tailpipes, single or twin tailpipes depending on engine variant
- 08 _ Diffuser insert in aluminium look



^^
^^
^^ 07 | 08

The S line sport package creates even more highlights and further enhances the vehicle's sporty character.

- 01 _ S sport seats, front, S line seat upholstery in optional fine Nappa leather, black with contrasting stitching in rock grey
(in conjunction with S line sport package the sport seats, front are equipped with S line seat upholstery in sequence cloth/leather as standard)
- 02 _ Matt brushed aluminium inlays
- 03 _ Gear or selector lever knob in black perforated leather
- 04 _ S line sport suspension
- 05 _ Illuminated door sill trims, front, with aluminium inlays and S logo
- 06 _ Pedals and footrest in stainless steel
- 07 _ Contrasting stitching in rock grey on seats, steering wheel, gear/selector lever knob and floor mats



^^
^^
^^ 01 | 02



^^
^^
^^ 03 | 04



^^
^^
^^ 05 | 06 | 07

Some of the equipment listed is optional equipment that is available at an extra charge. Please go to www.audi.com or visit your Audi partner for detailed information on standard and optional equipment. The figures for fuel consumption and CO₂ emissions can be found from page 110 onwards.

More striking. With the S line exterior package.

Don't just emphasise the sporty character of your A3 – enhance it. With the S line exterior package you add an even more thrilling touch to the dynamic body line and create special highlights with exceptional details.

- 01 _ Black air inlet grilles in honeycomb design
- 02 _ Chrome-plated trims for exhaust tailpipes, single or twin tailpipes depending on engine variant
- 03 _ Diffuser insert with honeycomb design
- 04 _ S line roof edge spoiler
- 05 _ Front and rear bumpers as well as side sill trims in a striking, sporty design
- 06 _ S line emblem on the front wings



Powerful look.

Select the paint colour that best suits your personality. Secure in the knowledge that the quality will be superb, because your vehicle is painted not just once, but four times. So not only do you look radiant in your Audi, your car is also protected from environmental influences and wear. Ensuring that the car maintains a powerful look throughout its entire lifetime.

Glacier white, metallic

Nano grey, metallic

Mythos black, metallic

Navarra blue, metallic

Ara blue, crystal effect¹

Tango red, metallic

Vegas yellow

Audi exclusive
customised paint finish
in solar orange²



^^
^^
^^ Cosmos blue, metallic

Some of the equipment listed is optional equipment that is available at an extra charge. Please go to www.audi.com or visit your Audi partner for detailed information on standard and optional equipment.

The figures for fuel consumption and CO₂ emissions can be found from page 110 onwards.

¹For information on when this feature will be available, please contact your Audi partner. ²From quattro GmbH.

Powerful presence.

With Audi wheels, you can emphasise your own individual style and the character of your Audi A3. Why not indulge yourself and create a powerful presence with your favourite design. For peace of mind on the road: Audi wheels are subjected to special test procedures, undergo rigorous testing and are of superb quality.

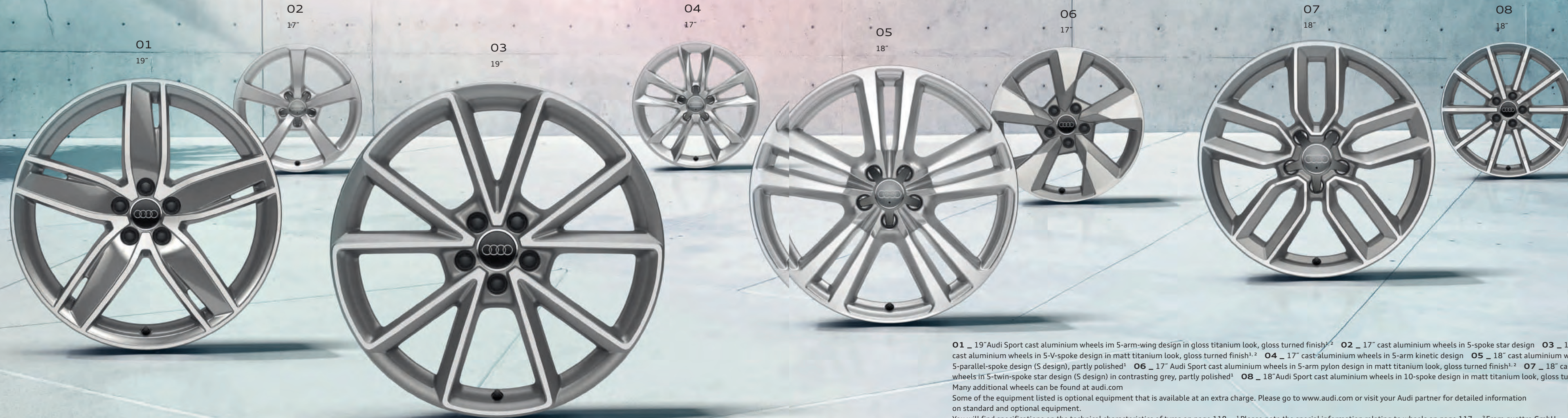

01
19"

02
17"

03
19"

04
17"

05
18"

06
17"

07
18"

08
18"

01 _ 19" Audi Sport cast aluminium wheels in 5-arm-wing design in gloss titanium look, gloss turned finish^{1,2} **02** _ 17" cast aluminium wheels in 5-spoke star design **03** _ 19" Audi Sport cast aluminium wheels in 5-V-spoke design in matt titanium look, gloss turned finish^{1,2} **04** _ 17" cast aluminium wheels in 5-arm kinetic design **05** _ 18" cast aluminium wheels in 5-parallel-spoke design (S design), partly polished¹ **06** _ 17" Audi Sport cast aluminium wheels in 5-arm pylon design in matt titanium look, gloss turned finish^{1,2} **07** _ 18" cast aluminium wheels in 5-twin-spoke star design (S design) in contrasting grey, partly polished¹ **08** _ 18" Audi Sport cast aluminium wheels in 10-spoke design in matt titanium look, gloss turned finish^{1,2}

Many additional wheels can be found at audi.com

Some of the equipment listed is optional equipment that is available at an extra charge. Please go to www.audi.com or visit your Audi partner for detailed information on standard and optional equipment.

You will find specifications on the technical characteristics of tyres on page 118. ¹Please note the special information relating to wheels on page 117. ²From quattro GmbH.



^^
^^
^^ 01



^^
^^
^^ 02



^^
^^
^^ 03

More sophisticated. With cloth and leather upholstery and trim.

You have a special place in your Audi. Exclusive comfort can be felt on the front and rear seats: thanks to high-quality materials and first-class workmanship. No matter which seat upholstery you choose, you are sitting in the right place.

01 _ S sport seat, front in fine Nappa leather, black with contrasting stitching 02 _ sport seat, front in plenum cloth/leather, black/cosmos blue with contrasting stitching 03 _ standard seat, front in regatta cloth, black

Some of the equipment listed is optional equipment that is available at an extra charge. Please go to www.audi.com or visit your Audi partner for detailed information on standard and optional equipment.

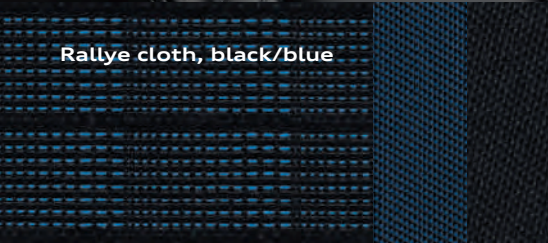

Rallye cloth, black/blue

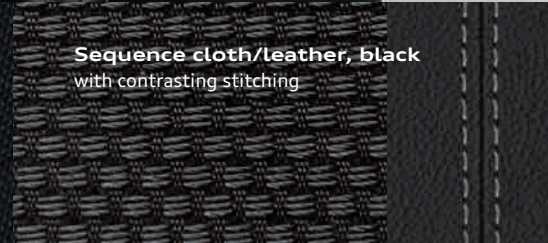

Sequence cloth/leather, black with contrasting stitching

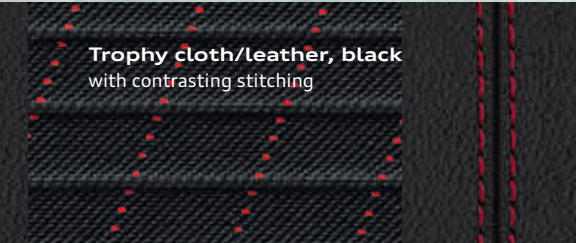

Trophy cloth/leather, black with contrasting stitching

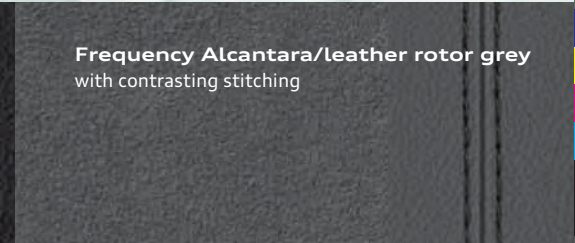

Frequency Alcantara/leather rotor grey with contrasting stitching

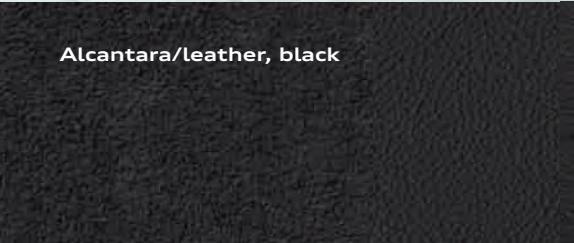

Alcantara/leather, black

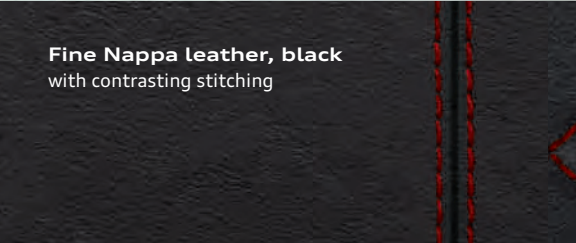

Fine Nappa leather, black with contrasting stitching



Fine Nappa leather, black with diamond pattern and contrasting stitching

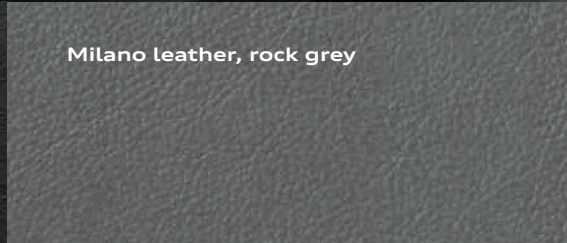

Milano leather, rock grey

^^
^^
^^
^ 3D-design "Optic", titanium grey

^^
^^
^^
^ Aluminium mistral

More exclusive. With inlays.

Exclusive ambience is a question of style. Your style. A style you can refine right down to the last detail. Create tangible accents with high-quality Audi inlays. Experience the fascination of exclusive materials – fine décors in 3D-design "Optic", titanium grey, aluminium mistral, silver, micrometallic, silver or matt brushed aluminium, design light – choose the ones that suit your personal taste.

^^
^^
^^
^ Micrometallic, silver

^^
^^
^^
^ Matt brushed aluminium, design light

Some of the equipment listed is optional equipment that is available at an extra charge. Please go to www.audi.com or visit your Audi partner for detailed information on standard and optional equipment.

As individual as the life you lead.

Audi Genuine Accessories provides you with numerous ways of adding even more facets to your Audi. With products that keep our quality promise day in, day out. Benefit from customised solutions that offer a winning combination of fascinating design and top functionality. Further information on these and other highlights is available from your Audi partner.

- 01_ **Snow chains** – for improved grip on snow and ice. Available in different sizes
- 02_ **Cycle fork mount** – allows for the comfortable transportation of bicycles on the carrier unit
- 03_ **Entrance LED** – projects the quattro logo or the Audi rings onto the background by LED light
- 04_ **USB adapter** – for charging various mobile phone models in conjunction with the Audi phone box
- 05_ **Audi child seat youngster plus** – combines safety with a high degree of comfort. For small passengers from 15 to 36 kg (approx. 4–12 years).
Also available: Audi baby seat (approx. 12 months) and Audi child seat (approx. 1–4 years)
- 06_ **Ski and luggage boxes** – in exclusive Audi design, can be locked and opened on both sides.
Available in the sizes 300 l, 360 l and 405 l

The figures for fuel consumption and CO₂ emissions can be found from page 110 onwards.

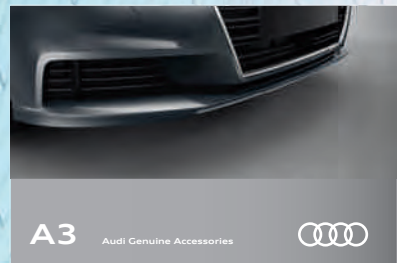

Detailed information can be obtained from the Audi A3 accessories catalogue, at www.audi.com, and from your Audi partner.

^^
^^
^^
^ 01



^^
^^
^^
^ 02



^^
^^
^^
^ 05



^^
^^
^^
^ 03



^^
^^
^^
^ 04



^^
^^
^^
^ 06



- 01_ **Cast aluminium wheels in 5-arm velum design** – in size 7.5 J x 18¹ ensure a dynamic appearance
- 02_ **Active pillow** – self-regulating air pillow promises comfortable sleep on the road
- 03_ **Luggage compartment tray** – protects the luggage space against soiling and damages caused by luggage. Only for the A3 Sportback
- 04_ **Tailgate spoiler, carbon** – supports the great aerodynamics of the saloon. With integrated brake lights
- 05_ **Exterior mirror housing in high-quality carbon** are a real eye-catcher and also save weight
- 06_ **All-weather floor mats** – help protect the vehicle interior against moisture and coarse soiling. With A3 logo

¹You will find specifications on the technical characteristics of tyres on page 118.



The fascination of the Audi A3. Find out more online.

Discover the world of the new Audi A3.
More information, more individuality
and more exclusivity. Now at www.audi.com.



Scan the QR code using your
smartphone or tablet and
discover the world of the new
Audi A3.



Model	A3/A3 Sportback 1.0 TFSI (85 kW)				A3/A3 Sportback 1.4 TFSI ultra (110 kW)				A3/A3 Sportback 2.0 TFSI (140 kW)				A3/A3 Sportback 2.0 TFSI quattro (140 kW)			
Engine type	3-cylinder inline petrol engine with direct fuel injection, turbocharging with indirect intercooler, 4-valve technology, 2 overhead camshafts				4-cylinder inline petrol engine with direct fuel injection, turbocharging with indirect intercooler, 4-valve technology, 2 overhead camshafts				4-cylinder inline petrol engine with direct fuel injection, turbocharging and Audi valvelift system (inlet side)				4-cylinder inline petrol engine with direct fuel injection, turbocharging and Audi valvelift system (inlet side)			
Displacement in cc (valves per cylinder)	999 (3)				1,395 (4)				1,984 (4)				1,984 (4)			
Max. output ¹ in kW at rpm	85/5,000–5,500				110/5,000–6,000				140/4,200–6,000				140/4,200–6,000			
Max. torque in Nm at rpm	200/2,000–3,500				250/1,500–3,500				320/1,500–4,200				320/1,500–4,200			
Power transmission																
Drive type	Front-wheel drive				Front-wheel drive				Front-wheel drive				quattro permanent all-wheel drive			
Transmission type	6-speed manual transmission [7-speed S tronic]				6-speed manual transmission [7-speed S tronic]				6-speed manual transmission [7-speed S tronic]				[7-speed S tronic]			
Weights/capacities	A3		A3 Sportback		A3		A3 Sportback		A3		A3 Sportback		A3		A3 Sportback	
Unladen weight ² in kg	1,225	[1,245]	1,255	[1,275]	1,275	[1,280]	1,305	[1,315]	1,330	[1,360]	1,360	[1,390]	[1,430]	[1,460]		
Gross vehicle weight in kg	1,710	[1,730]	1,740	[1,760]	1,760	[1,765]	1,790	[1,800]	1,815	[1,845]	1,845	[1,875]	[1,915]	[1,945]		
Permissible roof load limit/ nose weight in kg	75/75	[75/75]	75/75	[75/75]	75/75	[75/75]	75/75	[75/75]	75/75	[75/75]	75/75	[75/75]	[75/75]	[75/75]		
Trailer load limit ³ in kg unbraked	610	[620]	620	[630]	630	[640]	650	[650]	660	[680]	680	[690]	[710]	[730]		
12 % gradient	1,300	[1,300]	1,300	[1,300]	1,500	[1,500]	1,500	[1,500]	1,600	[1,600]	1,600	[1,600]	[1,600]	[1,600]		
8 % gradient	1,500	[1,500]	1,500	[1,500]	1,700	[1,700]	1,700	[1,700]	1,800	[1,800]	1,800	[1,800]	[1,800]	[1,800]		
Fuel tank capacity, approx. in l	50	[50]	50	[50]	50	[50]	50	[50]	50	[50]	50	[50]	[55]	[55]		
Performance/consumption⁴																
Top speed in km/h	206	[206]	206	[206]	220	[220]	220	[220]	244	[244]	244	[244]	[236]	[236]		
Acceleration 0–100 km/h in s	9.7	[9.7]	9.9	[9.9]	8.1	[8.1]	8.2	[8.2]	6.8	[6.7]	6.9	[6.8]	[6.1]	[6.2]		
Fuel grade	Sulphur-free super RON 95 ⁵				Sulphur-free super RON 95 ⁵				Sulphur-free super RON 95 ⁵				Sulphur-free super RON 95 ⁵			
Fuel consumption ^{6,7} in l/100 km urban	5.8–5.5	[5.7–5.4]	5.8–5.5	[5.7–5.4]	6.0–5.6	[6.0–5.7]	6.1–5.7	[6.2–5.9]	7.6–7.3	[7.4–7.1]	7.6–7.3	[7.4–7.1]	[7.4–7.1]	[7.4–7.1]		
extra-urban	4.2–3.9	[4.3–4.0]	4.2–3.9	[4.3–4.0]	4.3–3.9	[4.4–4.1]	4.4–4.0	[4.5–4.2]	4.8–4.5	[5.0–4.7]	4.8–4.5	[5.0–4.7]	[5.1–4.8]	[5.1–4.8]		
combined	4.8–4.5	[4.8–4.5]	4.8–4.5	[4.8–4.5]	4.9–4.5	[5.0–4.7]	5.0–4.6	[5.1–4.8]	5.8–5.5	[5.9–5.6]	5.8–5.5	[5.9–5.6]	[6.0–5.7]	[6.0–5.7]		
CO ₂ emissions ^{6,7} in g/km combined	110–104	[110–104]	110–104	[110–104]	112–105	[114–109]	115–107	[116–111]	132–126	[132–126]	132–126	[132–126]	[137–130]	[137–130]		
Emission standard	EU6	[EU6]	EU6	[EU6]	EU6	[EU6]	EU6	[EU6]	EU6	[EU6]	EU6	[EU6]	[EU6]	[EU6]		

[] Figures in square brackets refer to S tronic. Explanation of ¹ to ⁸ on page 117.

Model	S3/S3 Sportback 2.0 TFSI quattro (228 kW)				A3/A3 Sportback 1.6 TDI (81 kW)			
Engine type	4-cylinder inline petrol engine with direct fuel injection, turbocharging with intercooler, 4-valve technology, 2 overhead camshafts				4-cylinder inline diesel engine with VTG turbocharger and indirect intercooler, 2 overhead camshafts			
Displacement in cc (valves per cylinder)	1,984 (4)				1,598 (4)			
Max. output ¹ in kW at rpm	228 [228]/5,800 [5,500]–6,500 [6,500]				81/3,200–4,000			
Max. torque in Nm at rpm	380 [400]/1,850 [2,000]–5,700 [5,400]				250/1,500–3,000			
Power transmission								
Drive type	quattro permanent all-wheel drive				Front-wheel drive			
Transmission type	6-speed manual transmission [7-speed S tronic]				6-speed manual transmission [7-speed S tronic]			
Weights/capacities	S3		S3 Sportback		A3		A3 Sportback	
Unladen weight ² in kg	1,480	[1,505]	1,505	[1,540]	1,320/1,310*	[1,330]	1,350/1,335*	[1,360]
Gross vehicle weight in kg	1,965	[1,990]	1,990	[2,025]	1,805/1,795*	[1,815]	1,835/1,820*	[1,845]
Permissible roof load limit/ nose weight in kg	75/-	[75/-]	75/-	[75/-]	75/75	[75/75]	75/75	[75/75]
Trailer load limit ³ in kg unbraked	-	[-]	-	[-]	660/650*	[660]	670/660*	[680]
12 % gradient	-	[-]	-	[-]	1,000/1,500*	[1,500]	1,000/1,500*	[1,500]
8 % gradient	-	[-]	-	[-]	1,300/1,700*	[1,700]	1,300/1,700*	[1,700]
Fuel tank capacity, approx. in l	55	[55]	55	[55]	50	[50]	50	[50]
Performance/consumption⁴								
Top speed in km/h	250	[250]	250	[250]	200	[200]	200	[200]
Acceleration 0–100 km/h in s	5.2	[4.5]	5.3	[4.6]	10.5	[10.5]	10.7	[10.7]
Fuel grade	Sulphur-free super RON 98 ⁵				Sulphur-free diesel ⁸			
Fuel consumption ^{6,7} in l/100 km urban	9.2–9.1	[8.2–8.1]	9.2–9.1	[8.3–8.2]	4.9–4.3	[4.6–4.3]	4.9–4.3	[4.6–4.3]
extra-urban	5.9–5.8	[5.5–5.4]	5.9–5.8	[5.6–5.5]	3.8–3.5	[3.8–3.5]	3.8–3.5	[3.8–3.5]
combined	7.1–7.0	[6.5–6.4]	7.1–7.0	[6.6–6.5]	4.2–3.8	[4.1–3.8]	4.2–3.8	[4.1–3.8]
CO ₂ emissions ^{6,7} in g/km combined	163–162	[149–146]	163–162	[152–149]	109–99	[107–99]	109–99	[107–99]
Emission standard	EU6	[EU6]	EU6	[EU6]	EU6	[EU6]	EU6	[EU6]

* Figures after slashes apply to A3 sport/A3 design.

Model	A3/A3 Sportback 2.0 TDI (110 kW)				A3/A3 Sportback 2.0 TDI quattro (110 kW)				A3/A3 Sportback 2.0 TDI quattro (135 kW)			
Engine type	4-cylinder inline diesel engine with VTG turbocharger and indirect intercooler, 2 overhead camshafts				4-cylinder inline diesel engine with VTG turbocharger and indirect intercooler, 2 overhead camshafts				4-cylinder inline diesel engine with VTG turbocharger and indirect intercooler, 2 overhead camshafts			
Displacement in cc (valves per cylinder)	1,968 (4)				1,968 (4)				1,968 (4)			
Max. output ¹ in kW at rpm	110/3,500–4,000				110/3,500–4,000				135/3,500–4,000			
Max. torque in Nm at rpm	340/1,750–3,000				340/1,750–3,000				380/1,750–3,250			
Power transmission												
Drive type	Front-wheel drive				quattro permanent all-wheel drive				quattro permanent all-wheel drive			
Transmission type	6-speed manual transmission [6-speed S tronic]				6-speed manual transmission				[6-speed S tronic]			
Weights/capacities	A3		A3 Sportback		A3		A3 Sportback		A3		A3 Sportback	
Unladen weight ² in kg	1,350	[1,370]	1,380	[1,395]	1,435	1,465	[1,470]	[1,500]	1,335	[1,355]	1,380	[1,400]
Gross vehicle weight in kg	1,835	[1,855]	1,865	[1,880]	1,920	1,950	[1,955]	[1,985]	1,800	[1,820]	1,850	[1,870]
Permissible roof load limit/ nose weight in kg	75/75	[75/75]	75/75	[75/75]	75/75	75/75	[75/75]	[75/75]	75/75	[75/75]	75/75	[75/75]
Trailer load limit ³ in kg unbraked	670	[680]	690	[690]	710	730	[730]	[750]	660	[670]	680	[690]
12 % gradient	1,600	[1,600]	1,600	[1,600]	1,800	1,800	[1,800]	[1,800]	1,300	[1,300]	1,300	[1,300]
8 % gradient	1,800	[1,800]	1,800	[1,800]	1,800	1,800	[1,800]	[1,800]	1,500	[1,500]	1,500	[1,500]
Fuel tank capacity, approx. in l	50	[50]	50	[50]	55	55	[55]	[55]	50	[50]	50	[50]
Performance/consumption⁴												
Top speed in km/h	218	[218]	218	[218]	214	214	[230]	[230]	214	[214]	214	[214]
Acceleration 0–100 km/h in s	8.5	[8.2]	8.6	[8.3]	8.2	8.3	[6.8]	[6.9]	8.5	[8.2]	8.6	[8.3]
Fuel grade	Sulphur-free diesel ⁸				Sulphur-free diesel ⁸				Sulphur-free diesel ⁸			
Fuel consumption ^{6,7} in l/100 km urban	5.2–4.9	[5.5–5.2]	5.2–4.9	[5.5–5.2]	5.9–5.6	5.9–5.6	[5.7–5.4]	[5.7–5.4]	5.2–4.9	[5.5–5.2]	5.2–4.9	[5.5–5.2]
extra-urban	3.9–3.5	[4.3–4.0]	3.9–3.5	[4.3–4.0]	4.4–4.1	4.4–4.1	[4.6–4.3]	[4.6–4.3]	4.4–4.1	[4.3–4.0]	4.4–4.1	[4.3–4.0]
combined	4.4–4.0	[4.7–4.4]	4.4–4.0	[4.7–4.4]	5.0–4.7	5.0–4.7	[5.0–4.7]	[5.0–4.8]	4.4–4.0	[4.7–4.4]	4.4–4.0	[4.7–4.4]
CO ₂ emissions ^{6,7} in g/km combined	111–105	[122–116]	111–105	[122–116]	128–122	128–122	[131–124]	[131–124]	111–105	[122–116]	111–105	[122–116]
Emission standard	EU6	[EU6]	EU6	[EU6]	EU6	EU6	[EU6]	[EU6]	EU6	[EU6]	EU6	[EU6]

[] Figures in square brackets refer to S tronic. Explanation of ¹ to ⁸ on page 117.

Model	A3 Sportback g-tron 1.4 TFSI (81 kW)	
Engine type	4-cylinder inline petrol engine with gas and direct fuel injection, turbocharging with indirect intercooler, 4-valve technology, 2 overhead camshafts	
Displacement in cc (valves per cylinder)	1,395 (4)	
Max. output ¹ in kW at rpm	81/4,800–6,000	
Max. torque in Nm at rpm	200/1,500–3,500	
Power transmission		
Drive type	Front-wheel drive	
Transmission type	6-speed manual transmission [7-speed S tronic]	
Weights/capacities		
Unladen weight ² in kg	1,335	[1,355]
Gross vehicle weight in kg	1,800	[1,820]
Permissible roof load limit/ nose weight in kg	75/75	[75/75]
Trailer load limit ³ in kg unbraked	660	[670]
12 % gradient	1,300	[1,300]
8 % gradient	1,500	[1,500]
Fuel tank capacity, approx. in l	50	[50]
Fuel tank capacity, approx. in l (natural gas/CNG)	14.4	[14.4]

Model	A3 Sportback g-tron 1.4 TFSI (81 kW)	
Performance/consumption⁴		
Top speed in km/h	197	[197]
Acceleration 0–100 km/h in s	10.8	[10.8]
Fuel grade	CNG/sulphur-free super RON 95 ⁵	
Fuel consumption ^{6,7} in l/100 km urban	7.2–6.9	[6.6–6.3]
extra-urban	4.6–4.3	[4.7–4.4]
combined	5.5–5.2	[5.4–5.1]
Fuel consumption ^{6,7} natural gas (CNG) in kg/100 km urban	4.6–4.4	[4.3–4.2]
extra-urban	3.0–2.8	[2.9–2.7]
combined	3.6–3.4	[3.5–3.3]
CO ₂ emissions ^{6,7} in g/km urban	167–160	[153–145]
extra-urban	106–99	[107–101]
combined	128–121	[124–117]
CO ₂ emissions ^{6,7} natural gas (CNG) in g/km urban	127–121	[119–114]
extra-urban	82–76	[81–75]
combined	98–92	[95–89]
Emission standard	EU6	[EU6]

Model	A3 Saloon 1.0 TFSI (85 kW)	A3 Cabriolet 1.4 TFSI (85 kW)	A3 Saloon/A3 Cabriolet 1.4 TFSI ultra (110 kW)	A3 Saloon/A3 Cabriolet 2.0 TFSI (140 kW)
Engine type	3-cylinder inline petrol engine with direct fuel injection, turbocharging with indirect intercooler, 4-valve technology, 2 overhead camshafts	4-cylinder inline petrol engine with direct fuel injection, turbocharging with indirect intercooler, 4-valve technology, 2 overhead camshafts	4-cylinder inline petrol engine with direct fuel injection, turbocharging with indirect intercooler, 4-valve technology, 2 overhead camshafts	4-cylinder inline petrol engine with direct fuel injection, turbocharging and Audi valvelift system (inlet side)
Displacement in cc (valves per cylinder)	999 (3)	1,395 (4)	1,395 (4)	1,984 (4)
Max. output ¹ in kW at rpm	85/5,000–5,500	85/5,000–6,000	110/5,000–6,000	140/4,200–6,000
Max. torque in Nm at rpm	200/2,000–3,500	200/1,400–3,500	250/1,500–3,500	320/1,500–4,200
Power transmission				
Drive type	Front-wheel drive	Front-wheel drive	Front-wheel drive	Front-wheel drive
Transmission type	6-speed manual transmission [7-speed S tronic]	6-speed manual transmission [7-speed S tronic]	6-speed manual transmission [7-speed S tronic]	6-speed manual transmission [7-speed S tronic]
Weights/capacities			A3 Saloon	A3 Cabriolet
Unladen weight ² in kg	1,260 [1,280]	1,430 [1,450]	1,310 [1,320]	1,450 [1,470]
Gross vehicle weight in kg	1,735 [1,755]	1,855 [1,875]	1,785 [1,795]	1,875 [1,890]
Permissible roof load limit/ nose weight in kg	75/75 [75/75]	-/75 [-/75]	75/75 [75/75]	-/75 [-/75]
Trailer load limit ³ in kg unbraked	630 [640]	710 [720]	650 [660]	720 [730]
12 % gradient	1,300 [1,300]	1,400 [1,400]	1,500 [1,500]	1,500 [1,500]
8 % gradient	1,500 [1,500]	1,600 [1,600]	1,700 [1,700]	1,700 [1,700]
Fuel tank capacity, approx. in l	50 [50]	50 [50]	50 [50]	50 [50]
Performance/consumption⁴				
Top speed in km/h	211 [211]	203 [203]	224 [224]	222 [222]
Acceleration 0–100 km/h in s	9.9 [9.9]	10.6 [10.6]	8.2 [8.2]	8.9 [8.9]
Fuel grade	Sulphur-free super RON 95 ⁵	Sulphur-free super RON 95 ⁵	Sulphur-free super RON 95 ⁵	Sulphur-free super RON 95 ⁵
Fuel consumption ^{6,7} in l/100 km urban	5.8–5.5 [5.6–5.4]	7.1–6.9 [6.6–6.3]	6.1–5.7 [6.1–5.8]	6.3–5.9 [6.4–6.1]
extra-urban	4.1–3.8 [4.2–3.9]	4.7–4.4 [4.7–4.4]	4.3–3.9 [4.3–4.0]	4.5–4.1 [4.6–4.3]
combined	4.7–4.4 [4.7–4.4]	5.6–5.3 [5.4–5.1]	5.0–4.6 [5.0–4.7]	5.2–4.8 [5.2–4.9]
CO ₂ emissions ^{6,7} in g/km combined	109–103 [109–103]	126–120 [123–116]	114–106 [114–109]	119–110 [119–114]
Emission standard	EU6 [EU6]	EU6 [EU6]	EU6 [EU6]	EU6 [EU6]

[] Figures in square brackets refer to S tronic. Explanation of ¹ to ⁸ on page 117.

Model	A3 Saloon/A3 Cabriolet 2.0 TFSI quattro (140 kW)	S3 Saloon/S3 Cabriolet 2.0 TFSI quattro (228 kW)	A3 Saloon/A3 Cabriolet 1.6 TDI (81 kW)
Engine type	4-cylinder inline petrol engine with direct fuel injection, turbocharging and Audi valvelift system (inlet side)	4-cylinder inline petrol engine with direct fuel injection, turbocharging with intercooler, 4-valve technology, 2 overhead camshafts	4-cylinder inline diesel engine with VTG turbocharger and indirect intercooler, 2 overhead camshafts
Displacement in cc (valves per cylinder)	1,984 (4)	1,984 (4)	1,598 (4)
Max. output ¹ in kW at rpm	140/4,200–6,000	228 [228]/5,800 [5,500]–6,500 [6,500]	81/3,200–4,000
Max. torque in Nm at rpm	320/1,500–4,200	380 [400]/1,850 [2,000]–5,700 [5,400]	250/1,500–3,000
Power transmission			
Drive type	quattro permanent all-wheel drive	quattro permanent all-wheel drive	Front-wheel drive
Transmission type	[7-speed S tronic]	6-speed manual transmission [7-speed S tronic]	6-speed manual transmission [7-speed S tronic]
Weights/capacities	A3 Saloon	A3 Cabriolet	S3 Saloon
Unladen weight ² in kg	[1,465]	[1,630]	1,505 [1,545]
Gross vehicle weight in kg	[1,940]	[2,055]	1,980 [2020]
Permissible roof load limit/ nose weight in kg	[75/75]	[-/75]	75/- [75/-]
Trailer load limit ³ in kg unbraked	[730]	[750]	- [-]
12 % gradient	[1,600]	[1,600]	- [-]
8 % gradient	[1,800]	[1,800]	- [-]
Fuel tank capacity, approx. in l	[55]	[55]	55 [55]
Performance/consumption⁴			
Top speed in km/h	[242]	[242]	250 [250]
Acceleration 0–100 km/h in s	[6.2]	[6.9]	5.3 [4.6]
Fuel grade	Sulphur-free super RON 95 ⁵	Sulphur-free super RON 98 ⁵	Sulphur-free diesel ⁸
Fuel consumption ^{6,7} in l/100 km urban	[7.4–7.1]	[7.8–7.4]	9.2–9.1 [8.3–8.2]
extra-urban	[5.0–4.7]	[5.4–5.0]	5.9–5.8 [5.5–5.4]
combined	[5.9–5.6]	[6.3–5.9]	7.1–7.0 [6.5–6.4]
CO ₂ emissions ^{6,7} in g/km combined	[136–129]	[144–136]	163–162 [151–148]
Emission standard	[EU6]	[EU6]	EU6 [EU6]

* Figures after slashes apply to A3 sport/A3 design.

Model	A3 Saloon/A3 Cabriolet 2.0 TDI (110 kW)				A3 Saloon/A3 Cabriolet 2.0 TDI quattro (110 kW)				A3 Saloon/A3 Cabriolet 2.0 TDI quattro (135 kW)			
Engine type	4-cylinder inline diesel engine with VTG turbocharger and indirect intercooler, 2 overhead camshafts				4-cylinder inline diesel engine with VTG turbocharger and indirect intercooler, 2 overhead camshafts				4-cylinder inline diesel engine with VTG turbocharger and indirect intercooler, 2 overhead camshafts			
Displacement in cc (valves per cylinder)	1,968 (4)				1,968 (4)				1,968 (4)			
Max. output ¹ in kW at rpm	110/3,500–4,000				110/3,500–4,000				135/3,500–4,000			
Max. torque in Nm at rpm	340/1,750–3,000				340/1,750–3,000				380/1,750–3,250			
Power transmission												
Drive type	Front-wheel drive				quattro permanent all-wheel drive				quattro permanent all-wheel drive			
Transmission type	6-speed manual transmission [6-speed S tronic]				6-speed manual transmission				[6-speed S tronic]			
Weights/capacities	A3 Saloon		A3 Cabriolet		A3 Saloon		A3 Cabriolet		A3 Saloon		A3 Cabriolet	
Unladen weight ² in kg	1,385	[1,395]	1,535	[1,555]	1,470	1,615	[1,505]	[1,670]	[1,505]	[1,670]	[1,505]	[1,670]
Gross vehicle weight in kg	1,860	[1,870]	1,960	[1,980]	1,945	2,040	[1,980]	[2,095]	[1,980]	[2,095]	[1,980]	[2,095]
Permissible roof load limit/ nose weight in kg	75/75	[75/75]	–/75	[–/75]	75/75	–/75	[75/75]	[–/75]	[75/75]	[–/75]	[75/75]	[–/75]
Trailer load limit ³ in kg unbraked	690	[690]	750	[750]	730	750	[750]	[750]	[750]	[750]	[750]	[750]
12 % gradient	1,600	[1,600]	1,600	[1,600]	1,800	1,800	[1,800]	[1,800]	[1,800]	[1,800]	[1,800]	[1,800]
8 % gradient	1,800	[1,800]	1,800	[1,800]	1,800	1,800	[1,800]	[1,800]	[1,800]	[1,800]	[1,800]	[1,800]
Fuel tank capacity, approx. in l	50	[50]	50	[50]	55	55	[55]	[55]	[55]	[55]	[55]	[55]
Performance/consumption⁴												
Top speed in km/h	224	[224]	224	[224]	220	220	[237]	[237]	[237]	[237]	[237]	[237]
Acceleration 0–100 km/h in s	8.6	[8.3]	8.9	[8.8]	8.3	8.8	[6.9]	[7.6]	[6.9]	[7.6]	[6.9]	[7.6]
Fuel grade	Sulphur-free diesel ⁸				Sulphur-free diesel ⁸				Sulphur-free diesel ⁸			
Fuel consumption ^{6,7} in l/100 km urban	5.2–4.9	[5.5–5.2]	5.4–5.1	[5.7–5.4]	5.9–5.6	6.1–5.8	[5.7–5.4]	[6.0–5.7]	[5.7–5.4]	[6.0–5.7]	[5.7–5.4]	[6.0–5.7]
extra-urban	3.9–3.5	[4.3–4.0]	4.1–3.7	[4.5–4.2]	4.4–4.1	4.5–4.2	[4.6–4.3]	[4.8–4.5]	[4.6–4.3]	[4.8–4.5]	[4.6–4.3]	[4.8–4.5]
combined	4.4–4.0	[4.7–4.4]	4.6–4.2	[4.9–4.6]	5.0–4.7	5.1–4.8	[5.0–4.7]	[5.2–4.9]	[5.0–4.7]	[5.2–4.9]	[5.0–4.7]	[5.2–4.9]
CO ₂ emissions ^{6,7} in g/km combined	110–104	[121–115]	117–110	[127–120]	128–122	132–125	[131–124]	[137–129]	[131–124]	[137–129]	[131–124]	[137–129]
Emission standard	EU6	[EU6]	EU6	[EU6]	EU6	EU6	[EU6]	[EU6]	[EU6]	[EU6]	[EU6]	[EU6]

[] Figures in square brackets refer to S tronic. Explanation of ¹ to ⁸ on page 117.

Explanatory notes

- ¹ The figure given was calculated using the specified measuring procedure (current version of UN-R 85).
- ² Unladen vehicle weight includes driver (75 kg) and fuel tank 90 % full, calculated in accordance with the current version of Reg. (EU) 1230/2012. Optional equipment may increase the car's unladen weight and drag coefficient, whereupon the possible payload limit and the top speed will be reduced accordingly.
- ³ The engine's power output always decreases with increasing altitude. At 1,000 m above sea level, and for every additional 1,000 m, deduct 10 % from the weight of the outfit (trailer load limit + gross weight of the towing vehicle). Figure for trailer load limit applies to factory-fitted trailer towing hitch. If using the vehicle with a trailer towing hitch for commercial purposes, a digital tachograph may be required under certain conditions.
- ⁴ Fuel consumption and CO₂ emission figures given in ranges depend on the tyre/wheel sets used.
- ⁵ We recommend using sulphur-free super unleaded RON 95 fuel complying with DIN EN 228. If this is not available, use sulphur-free regular unleaded RON 91 fuel complying with DIN EN 228; power output will be slightly reduced. Unleaded RON 95 fuel with a maximum ethanol content of 10 % (E10) can generally be used. Fuel consumption details refer to operation with RON 95 fuel complying with 692/2008/EC.
- ⁶ The figures given were calculated using the specified measuring procedures. The figures do not refer to one individual vehicle and do not form part of any offer, but rather should be used purely for purposes of comparison between the different vehicle models.
- ⁷ A vehicle's fuel consumption and CO₂ emissions do not just depend on how efficiently the vehicle uses the fuel, but are also influenced by driving behaviour and other non-technical factors. CO₂ is the greenhouse gas primarily responsible for global warming.
- ⁸ We recommend using sulphur-free diesel complying with DIN EN 590. If this is not available, use diesel complying with DIN EN 590.

Important note

Special information about the wheels: Wheels with gloss turned finish as well as polished or partly polished aluminium wheels must not be used in wintry road conditions. For manufacturing reasons, the rim surface does not have sufficient corrosion protection for such use and can be damaged permanently by road salt or similar.

Legal notice about Audi connect

Use of the services supported by Audi connect is possible only in conjunction with an optional navigation system. Audi connect services are provided through AUDI AG. The data connection for the Audi connect services is set up through a mobile services provider via a SIM card permanently installed in the vehicle. The costs of these data connections are included in the price of Audi connect services. The costs for the Wi-Fi hotspot are not included. The data connection for the Wi-Fi hotspot can be arranged with a selected mobile services provider as a payable data tariff. You will find information about tariffs and booking at www.audi.com/myaudi. Alternatively, a customer SIM card can be inserted into the card slot to establish a data connection. In conjunction with the optional equipment Audi phone box, a Bluetooth-capable smartphone with remote SIM Access Profile (rSAP)¹ can also be connected to use the integrated car phone function. If an external SIM card is inserted into the card slot or connected via rSAP, all data connections both for the Audi connect services as well as for the Wi-Fi hotspot will be established via this external SIM card. In such cases, the costs incurred are attached to those accrued via the external SIM card.

The availability of the services supported by Audi connect varies from country to country. The Audi connect services are provided for at least 1 year from vehicle delivery. Following a period of 24 months from vehicle delivery, Audi connect services will be extended once free of charge for 12 months. If you do not require this extension, please write to:

AUDI AG
Audi International Customer Care Services
85045 Ingolstadt, Germany
Email: kundenbetreuung@audi.de
Tel.: +49 800 28347378423

Ask your Audi partner about a subsequent extension of the Audi connect services.

Depending on the vehicle model, Audi connect enables access to Google and Twitter services. Permanent availability cannot be guaranteed; Google and Twitter are responsible for this. Please visit www.audi.com/connect or contact your Audi partner for more detailed information about Audi connect; contact your mobile services provider for information about contract conditions.

¹Please contact your Audi partner or visit www.audi.com/bluetooth for information on compatible mobile phones.

Classifications of tyre parameters

The table shows the range of fuel efficiency, wet grip and exterior noise emission classes for the different tyre sizes of the A3/S3 models.

	Tyre size	Fuel efficiency class	Wet grip class	Exterior noise emission class	
Summer tyres	205/55 R 16	F-B	E-A	70-67	-
	225/45 R 17	E-C	C-A	71-67	-
	225/40 R 18	F-C	B-A	72-67	-
	235/35 R 19	E	B	72	
Winter tyres	205/55 R 16	E	C-B	72-68	-
	205/50 R 17	F-C	E-B	71-69	-
	225/40 R 18	F-E	E-B	72-69	-

It is not possible to order a specific tyre. Ask your Audi partner about the range of tyres available in your country.

Equipment for the Audi A3 Sportback illustrated (p. 2-49):
Paint finish: nano grey, metallic
Wheels: cast aluminium wheels in 5-arm dynamic design
Seats/seat upholstery: sport seats, front in sequence cloth/leather, black with contrasting stitching in rock grey
Inlays: matt brushed aluminium, design light
Further equipment: S line exterior package

Equipment for the Audi A3 illustrated (p. 2-49):
Paint finish: Vegas yellow
Wheels: cast aluminium wheels in 5-arm dynamic design
Seats/seat upholstery: S sport seats, front in fine Nappa leather, rotor grey with contrasting stitching in anthracite with diamond pattern
Inlays: matt brushed aluminium, design light
Further equipment: S line exterior package

Equipment for the Audi A3 Saloon illustrated (p. 2-49):
Paint finish: cosmos blue, metallic
Wheels: cast aluminium wheels in 5-V-spoke design, matt titanium look, gloss turned finish¹
Seats/seat upholstery: sport seats, front in plenum cloth/leather, black/blue with contrasting stitching in space blue
Inlays: matt brushed aluminium
Further equipment: S line exterior package

Equipment for the Audi A3 Cabriolet illustrated (p. 2-49):
Paint finish: tango red, metallic
Wheels: cast aluminium wheels in 5-V-spoke design, matt titanium look, gloss turned finish¹
Seats/seat upholstery: S sport seats, front in fine Nappa leather, black with contrasting stitching in rock grey with diamond pattern
Inlays: matt brushed aluminium, design light
Further equipment: S line exterior package

Equipment for the Audi S3 Sportback illustrated (p. 50-81):
Paint finish: Daytona grey, pearl effect
Wheels: Audi Sport cast aluminium wheels in 5-V-spoke design, matt titanium look, gloss turned finish^{1,2}
Seats/seat upholstery: sport seats, front in fine Nappa leather, black/express red
Inlays: matt brushed aluminium, design light

Equipment for the Audi S3 illustrated (p. 50-81):
Paint finish: Vegas yellow
Wheels: Audi Sport cast aluminium wheels in 5-arm wing design, titanium look, gloss²
Seats/seat upholstery: S sport seats, front in fine Nappa leather, black
Inlays: matt brushed aluminium, design light

Equipment for the Audi S3 Saloon illustrated (p. 50-81):
Paint finish: panther black, crystal effect
Wheels: Audi Sport cast aluminium wheels in 5-arm wing design, titanium look, gloss²
Seats/seat upholstery: S sport seats, front in fine Nappa leather, black with contrasting stitching in express red
Inlays: matt brushed aluminium, design light

Equipment for the Audi S3 Cabriolet illustrated (p. 50-81):
Paint finish: navarra blue, metallic
Wheels: cast aluminium wheels in 5-twin-spoke star design, contrasting grey, partly polished¹
Seats/seat upholstery: S sport seats, front in frequency Alcantara/leather, rotor grey with contrasting stitching in anthracite
Inlays: matt brushed aluminium, design light

¹Please note the special information relating to wheels on page 117. ²From quattro GmbH.

Audi A3 Dimensions in mm

Dimensions are for vehicle at unladen weight. Luggage compartment volume:¹ front-wheel drive 365/1,100 l; quattro permanent all-wheel drive 325/1,060 l (second value: with the rear seat backrest folded down and vehicle loaded up to roof height). Turning circle approx. 10.7 m.
*Maximum headroom. **Elbow room width. ***Shoulder room width.

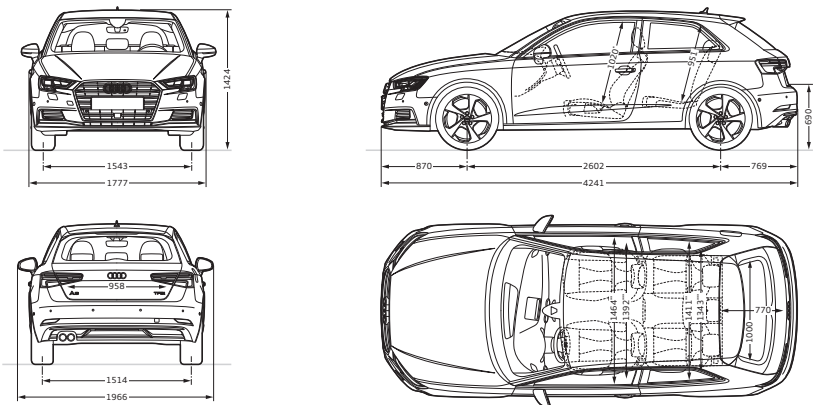

Audi S3 Dimensions in mm

Dimensions are for vehicle at unladen weight. Luggage capacity:¹ 325/1,060 l (second value is with the rear seat backrest folded down and the vehicle loaded up to roof height). Turning circle approx. 10.7 m.
*Maximum headroom. **Elbow room width. ***Shoulder room width.

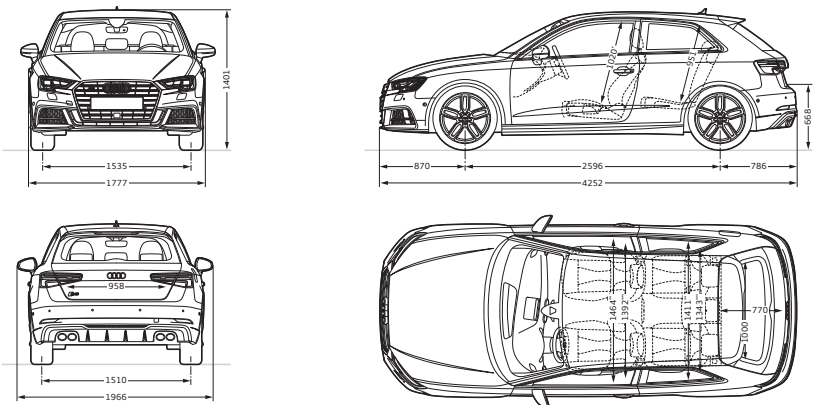

Audi A3 Saloon Dimensions in mm

Dimensions are for vehicle at unladen weight. Luggage compartment volume:¹ front-wheel drive 425/880 l; quattro permanent all-wheel drive 390/845 l (second value: with the rear seat backrest folded down and vehicle loaded up to the parcel shelf). Turning circle approx. 11.0 m.
*Maximum headroom. **Elbow room width. ***Shoulder room width.

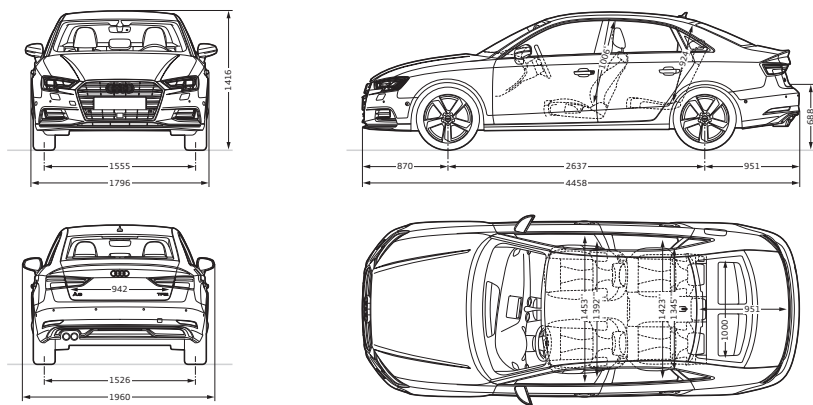

Audi S3 Saloon Dimensions in mm

Dimensions are for vehicle at unladen weight. Luggage capacity:¹ 390/845 l (second value with the rear seat backrest folded down and vehicle loaded up to the rear parcel shelf). Turning circle approx. 11.0 m.
*Maximum headroom. **Elbow room width. ***Shoulder room width.

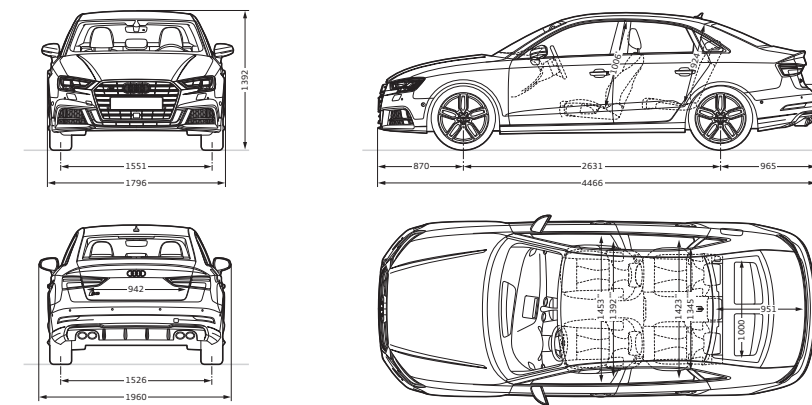

Audi A3 Sportback Dimensions in mm

Dimensions are for vehicle at unladen weight. Luggage compartment volume:¹ front-wheel drive 380/1,220 l; quattro permanent all-wheel drive 340/1,180 l (second value: with the rear seat backrest folded down and vehicle loaded up to roof height). Turning circle approx. 10.9 m.
*Maximum headroom. **Elbow room width. ***Shoulder room width.

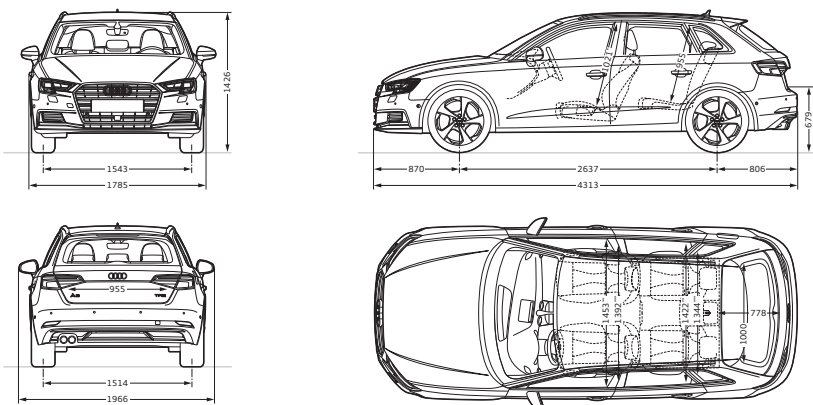

Audi S3 Sportback Dimensions in mm

Dimensions are for vehicle at unladen weight. Luggage capacity:¹ 340/1,180 l (second value is with the rear seat backrest folded down and the vehicle loaded up to roof height). Turning circle approx. 10.9 m.
*Maximum headroom. **Elbow room width. ***Shoulder room width.

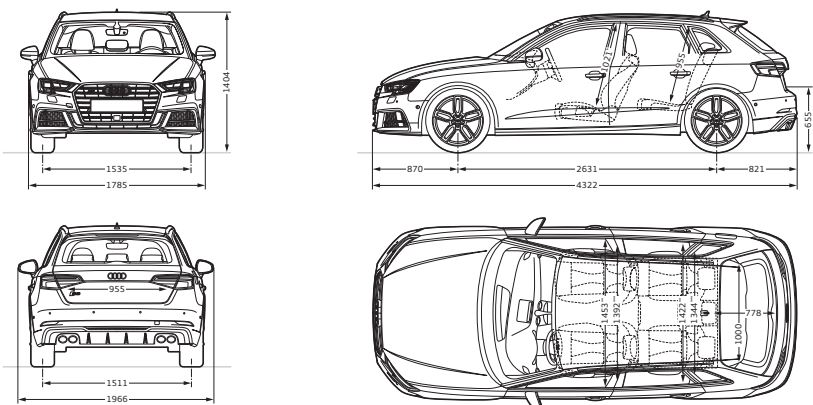

Audi A3 Cabriolet Dimensions in mm

Dimensions are for vehicle at unladen weight. Luggage compartment volume¹ with closed hood: front-wheel drive 320 l, quattro permanent all-wheel drive 285 l; with open hood: front-wheel drive 280 l, quattro permanent all-wheel drive 245 l; with the rear seat backrest folded down: front-wheel drive 680 l, quattro permanent all-wheel drive 645 l. Turning circle approx. 10.9 m.
*Maximum headroom. **Elbow room width. ***Shoulder room width.

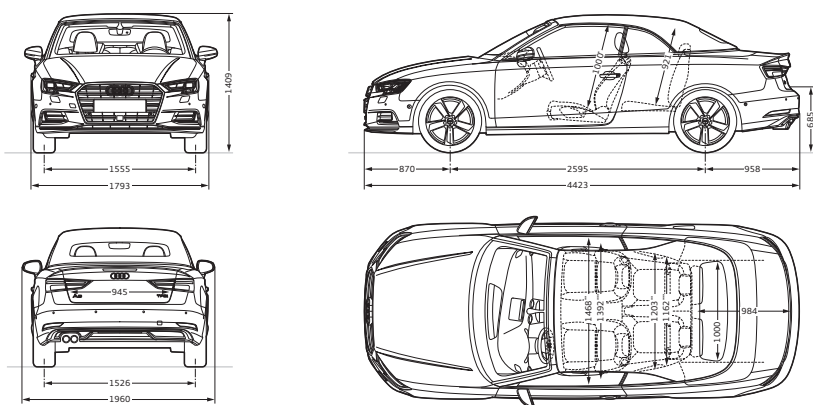

Audi S3 Cabriolet Dimensions in mm

Dimensions are for vehicle at unladen weight. Luggage compartment volume¹ with closed hood: 285 l; with open hood 245 l; with the rear seat backrest folded down 645 l. Turning circle approx. 10.9 m.
*Maximum headroom. **Elbow room width. ***Shoulder room width.

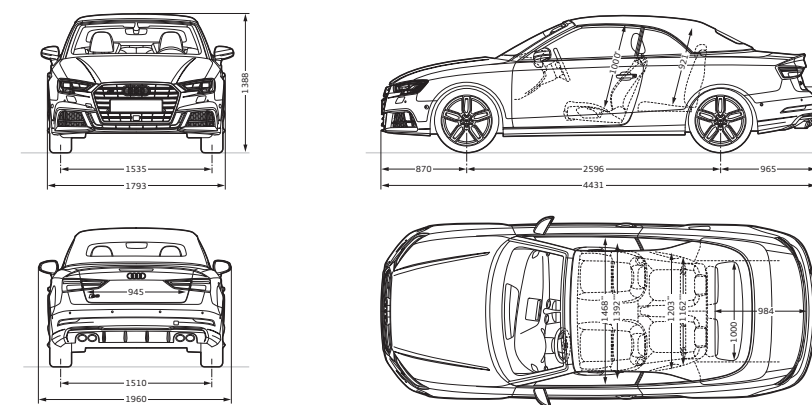

¹Technical specifications refer to a basic vehicle without country-specific settings and the selected optional equipment.

¹Technical specifications refer to a basic vehicle without country-specific settings and the selected optional equipment.

AUDI AG

Auto-Union-Strasse 1
85045 Ingolstadt
www.audi.com
Valid from June 2016

Printed in Germany
633/1153.32.18

The models and equipment versions illustrated and described in this brochure and some of the services listed are not available in all countries. Some of the cars illustrated are equipped with optional features for which an extra charge is made. Details concerning the delivery specifications, appearance, performance, dimensions and weights, fuel consumption and running costs of the vehicle were correct to the best of our knowledge at the time of going to press. Deviations from the colours and shapes shown in the illustrations may occur. No liability is accepted for errors and printing errors. The right to introduce modifications is reserved. Not to be reproduced, including in part, without the written approval of AUDI AG.

This brochure is printed on paper made from pulp bleached without the use of chlorine.

