

quattro GmbH



Audi

RS 4

Saloon and Avant





**If you succeed here, you will succeed anywhere.
The Audi RS 4 on the racetrack.**

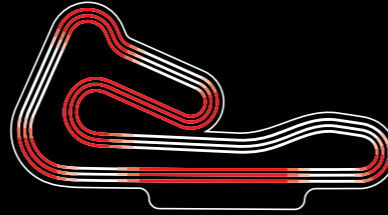

Is there a better place to be than the driving seat of a racing car? The feeling of controlling incredible power. The tremendous acceleration that presses on your stomach. The tingling in your neck at top speed. The desire to match others. It is probably the combination of all this that makes motorsport so fascinating. However, the most important thing is having the right car. A sports car that is like motorsport itself – exciting, powerful and extreme. The Audi RS 4.



Find out for yourself – Saloon or Avant. Accompany us to a place where you have firsthand experience of the full power of motorsport: to the driver's seat of the Audi RS 4.



Six challenges await you in the five sections of the course. Right after the start you encounter the first one – a complicated combination of a left-hand bend and a left-right bend. You can then enjoy the exceptional acceleration and torque of the Audi RS 4 on



the straight that follows. The next section with two 180° hairpin bends and a demanding left-hand bend requires the utmost concentration. Here the Audi RS 4 shows how impressively it combines power and control, exact handling and dynamic driving. One more bend, and then you have the finish line in sight. So much for the theory.



Now for the practise: Get in.



Start »



- 1 Engine » 02//03**  

Extreme acceleration and exceptional performance are required on the long start and finish straights.
- 2 Brakes » 08//09**  

You need to brake before the first left-hand bend in order to drive out of the bend at the highest possible speed into the next left-right combination.
- 3 quattro » 12//13**  

In the two successive 180° hairpin bends the quattro® drive maintains your ideal line.
- 4 Safety » 16//17**  

The left-hand bend is particularly tricky: Shortly before the actual bend there is a slight bend to the right. The Electronic Stabilization Programme ESP 8.0 ensures safety.
- 5 Dynamic Ride Control » 18//19**  

The sharp left-hand bend produces powerful load changes. The RS 4 with Dynamic Ride Control, DRC, dampens these changes
- 6 Design » 24//25**  

You've arrived at the finish line. Time to take a closer look at the RS 4: its athletic design, its sporty cockpit and its high-quality equipment.

Finish »





You're in control of 8 cylinders, 309 kW and 430 Nm.

How can you control yourself?

In either the RS 4 saloon or the RS 4 Avant – the biggest challenge comes before you start: self control. The tarmac shimmers in front of you. You glance at the traffic lights. Any minute now. You push the engine starter button. The powerful noise of the 4.2 litre V8 engine*

sends a judder of anticipation through you. It reaches your hands. You shift into first gear. Your patience is pushed to its limits. You've got 309 kW and 430 Nm torque waiting under the bonnet. Awesome power that you are about to let loose.

*The fuel consumption and CO₂ emissions figures can be found in the "Technical Data" section on page 49.

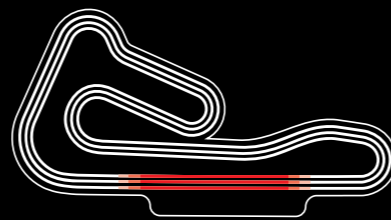
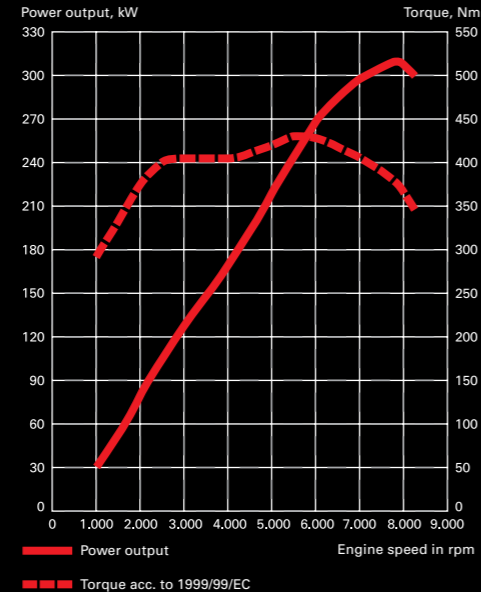

Lap times are what count in motorsport.
Your best time is 8,250 revs per minute.

Only a few moments left. Your foot is on the accelerator. Slight pressure and throbbing of the V8 FSI® engine* reminds you what thrust force awaits you. The provenance of the 4.2 litre powertrain promises a great deal. In the Le Mans 24-hour race and the DTM the Audi engines have impressively demonstrated

their uniqueness and potential with numerous successes.

In the RS 4 Audi has, for the first time, turned these experiences into a high-rev concept. The result is a free-revving, high-performance powertrain.

Particular characteristics: 309 kW at 7,800 rpm and 430 Nm at 5,500 rpm. More than 90 % of this power is available between 2,250 and 7,600 rpm. Extreme performance that never ceases to impress you each time you drive it. Prepare yourself.

*The fuel consumption and CO₂ emission data can be found under "Technical Data" on page 49.





How fast you get carried away depends on
one thing only: the speed of your responses.

The light changes. A fraction of a second later your foot goes down. The V8-FSI® engine* responds instantaneously to catapult you from standstill to 100 km/h (saloon) in just 4.8 seconds. The new high-speed drive concept of the RS 4 transfers its enormous power and its outstanding performance to the road

over an extraordinarily wide engine speed spectrum. After another 11.8 seconds you reach 200 km/h (saloon) You're forced back into your seat by the thrust. Fascination becomes delight. Every mile you cover makes you crave more of this unbelievable power.



*The fuel consumption and CO₂ emission data can be found under "Technical Data" on page 49.



Extreme brake power offers safety.

And brings you back on course more quickly.

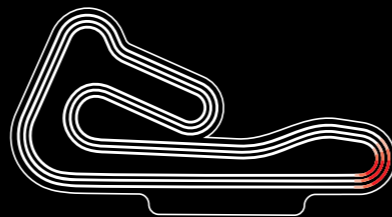

The first challenge is in sight: a demanding left-hand bend. You steer towards the right edge of the track. You reach the first braking point at top speed. Now. You press the brake pedal with all your strength. The brakes respond immediately. For a moment the tremendous deceleration presses you into your seat-belt. What you are so spectacularly experiencing is the 18-inch braking system with which the Audi RS 4 controls its ultimate power. The high-performance braking system, which has been adapted from motor

racing, with floating, perforated composite brake discs and 8-piston fixed brake callipers on the front axis and direct cooling air delivered through Naca ducts, guarantees consistently stable braking power in keeping with the high level of driving performance even in extreme conditions. The braking system is supported by the Electronic Stabilization Programme ESP 8.0. The brake pads grip the discs with their enormous power. With extreme deceleration the RS 4 brakes within a split second of the bend. You change

down a gear so that the RS 4 passes through the bend with controlled speed.

You take your foot off the pedal and steer slightly to the left. Then take a breath and accelerate, but don't overdo it as the excitement continues immediately into the next left-right combination and then towards the back straight.







**Extreme cornering requires lots of sensitivity.
And even more quattro.**

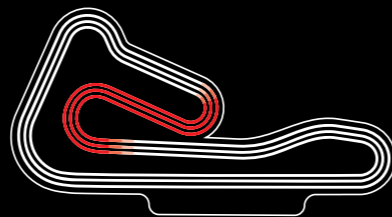

Full throttle up a slight incline. Both hands firmly on the steering wheel. At the end of the straight you reach the double section with two 180° hairpin bends. No easy task as the fast first bend is followed by a short sprint stretch and then the second bend which gradually widens out towards the end. The enormous centrifugal forces in the protracted bends and the intense speed differences make this section particularly demanding.

You pass into the first of the two hairpin bends from the far outside. Everything happens as quick as lightning. Take your foot off the accelerator, brake, change down a gear, steer. And then pass through the bend in the middle, as far as possible towards the inside. Press the pedal lightly. The momentum of the V8 engine* pushes you forwards. You pull onto the back straight diagonally to the right. Again you brake and steer to the left. The power from cornering pushes you to the outside. The Audi RS 4 counters this with

impressive roadholding. Unperturbed the car remains on the ideal line. The permanent quattro® all-wheel drive with asymmetric-dynamic torque distribution gives a high level of roadholding and traction. And it ensures maximum thrust. When you come out of the bend there is a slight incline and then you continue straight on. You increase your speed. Thanks to quattro®, all the Audi RS 4's power is directed towards the road whatever the course. Breathe deeply and enjoy.

*The fuel consumption and CO₂ emission data can be found under "Technical Data" on page 49.

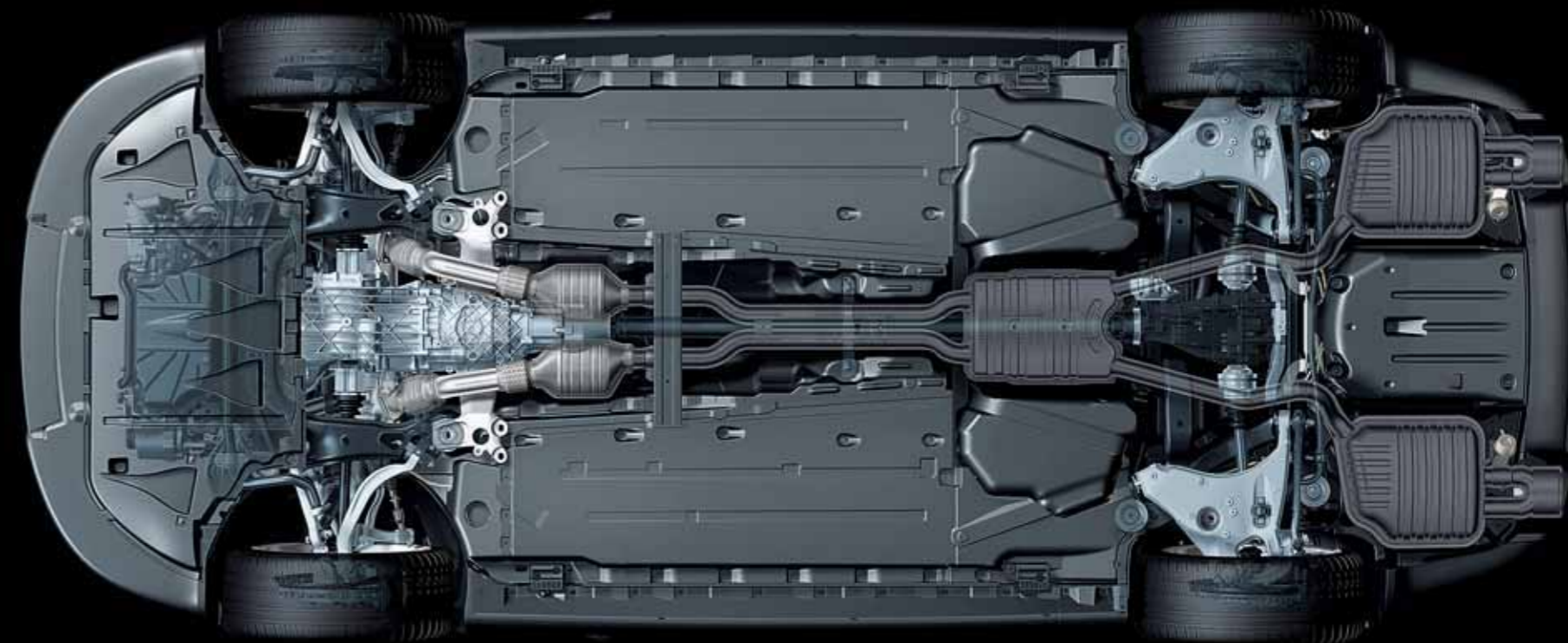





**Good drivers use their instincts for every situation.
Good cars have intelligent technology.**



No time to look at the scenery. Colours and shapes fly past to left and right. All your attention is focussed on the road ahead. On the straight you accelerate in 2nd gear to 100 km/h. And on and on. Once again your full concentration is required as the track veers slightly to the right before the sharp left-hand bend. Now turn the steering wheel a little to the right and then brake. Watch out, there is gravel on the road. Instinctively you swerve to the left. Steer again and take a deep breath. Everything is under control. The Audi RS 4 is intelligent.

With specific intervention on individual wheels the Electronic Stabilization Programme ESP 8.0 provides good roadholding and safe handling. Quicker than you can blink, in only 0.02 seconds, the intelligent system activates all the active safety components: anti-lock braking system (ABS), traction control, electronic brake force distribution and electronic differential lock. Additional safety is provided by driver and passenger airbags, the sideguard head-level airbag system and the RS bucket seats that thanks to their exceptional lateral stability correspond to the current safety standards without the side airbags. So in the RS 4 you have the safety you expect and the sportiness that makes your heart beat faster.

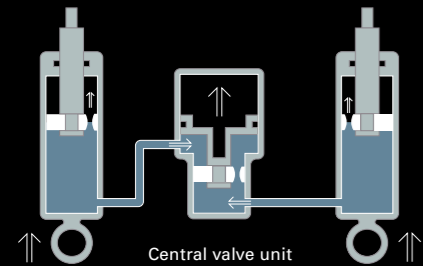

Position 01

With simultaneous compression the valves offer no resistance and the DRC system's oil flow is balanced. This leads to a high level of driving comfort.

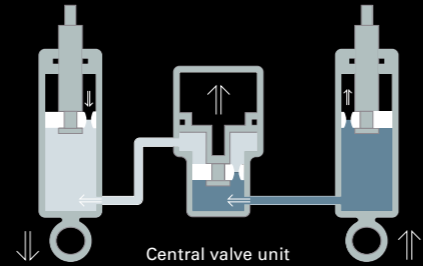

Position 02

With alternating compression the valve-controlled DRC system ensures pressure build up on the compressed wheel and increases the damping effect there. The result is roll-free handling.



Even the ideal line can be improved.

With the right roadholding.

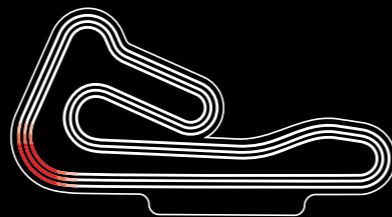

Once again the course bends sharply to the left. The standard integrated lap timer in the driver information system promises a perfect lap time. Now what is needed is precise steering. As it is only by driving at high speed on the straight for as long as possible and steering through the bends at ideal speed that you do not lose any time. At the apex, you accelerate slightly. The quick change of direction presses you into the side panel of the RS bucket seat. Thanks to its high stability and precise steering even during fast driving manoeuvres the RS 4 handles the sharp left-hand bend as precisely and dynamically as you

would expect from a sports car. Its advantage: the sports suspension with Dynamic Ride Control DRC.

When steering the hydraulic roll adjustment, DRC, varies the damping of each individual shock absorber. In this way rolling during cornering and pitching in the longitudinal axle during braking or acceleration is reduced.

This improved wheel load distribution ensures outstanding driving dynamics and optimum drive power from all four wheels. This enables you to pass

through the bend sections more quickly and allows you direct acceleration out of the bends. No wonder that the RS 4 masters any road convincingly and safely even away from the racetrack. The lowered chassis combined with the low profile tyres also improve handling and ensure better traction. On the last section of the course there is only one thing to do: drive at full throttle to the finish line.

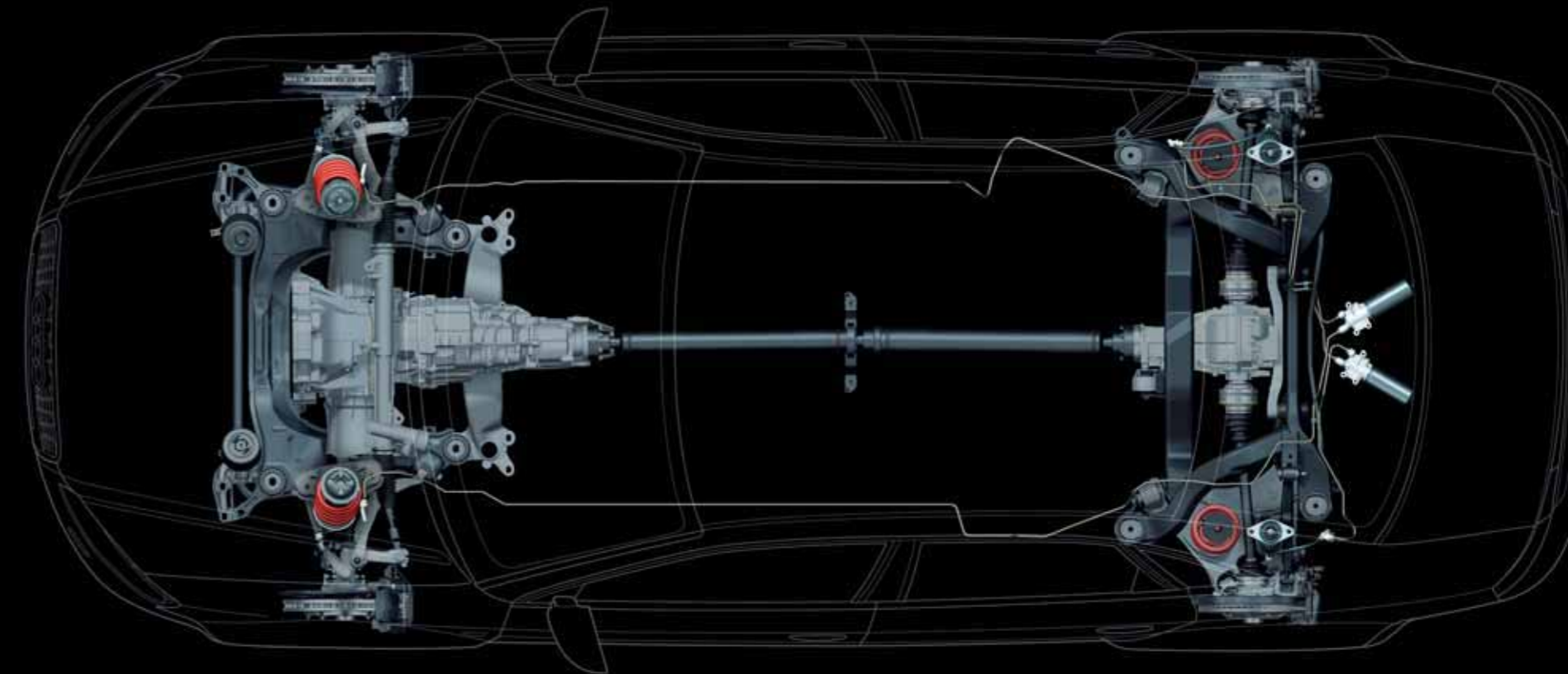





Acceleration can be this easy: 3.93 kg per hp.

Only a few more metres to the finish line. You have rarely experienced such impressive acceleration. Once again the tremendous power of the RS 4 presses you into the seat. From 100 to 200 km/h in only 11.8 seconds (saloon). Its power/weight ratio of 3.93 kg/hp (saloon) makes it so extraordinarily spontaneous and powerful.

A unique driving experience without any limitations, sporty and ultimately at the same time. You steer gently to the right, as close as possible to the grandstand and the pit lane. Wide awake you enjoy every moment. A quick look at the lap timer. What a lap time. What an experience. There is no better feeling.



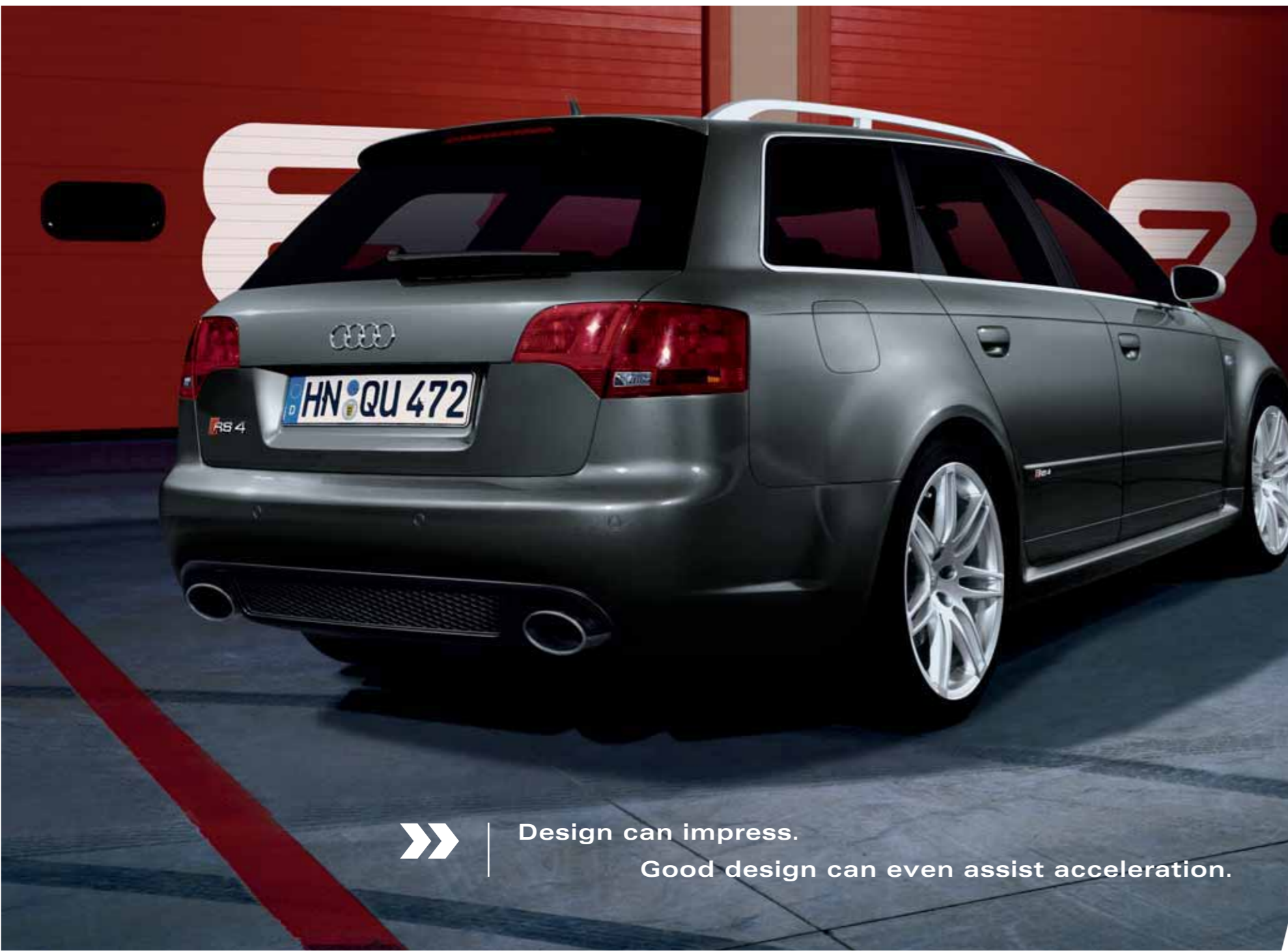

Design can impress.

Good design can even assist acceleration.



100 metres. 50 metres. The RS 4 flies over the finish line. You take your foot off the accelerator – time to be admired. With a striking front apron, athletic lines and a matt aluminium exterior trim, the Audi RS 4 radiates performance and self-confidence. The dynamic side contours stretch towards the front of the car. RS 4 design bumpers, exposed wheel arches and

broadened sills all add to its sporty look. But it is never about the design alone. Each shape also supports you when you are driving and increases the ride quality of the RS 4. The integrated rear spoiler of the RS 4 saloon and the roof edge spoiler of the RS 4 Avant increase the contact pressure. The front air intakes provide the V8 naturally aspirated engine*

with an optimum supply of cooling air. The lowered suspension improves roadholding. And the optional 19-inch cast aluminium wheels assist the power transmission to the road. Design elements that will help you to gain crucial seconds in each lap.

*The fuel consumption and CO₂ emission data can be found under "Technical Data" on page 49.









» Styling package including exhaust tailpipes, roof rails and matt black exterior trim.



» Ceramic braking system



» Floor mats with RS 4 logo



» Radiator grill frame, highly-polished, black



A race is not decided on the track.
But in the cockpit.



Time to lean back. Look around the cockpit of the Audi RS 4. Everything is where you would expect it to be. The interior is characterised by a sporty design and high-quality materials. The RS instrument cluster gives you the most important information

in any situation. The RS sports steering wheel offers optimum grip for sporty driving thanks to its flattened underside and embossed rim. And with its additional functions the Audi RS 4 is an even more dynamic experience: One press of the sport

button improves the subjective response of the accelerator even more, increases the engine sound experience by adjusting the exhaust door and adjusts the side bolsters of the RS bucket seat to fit your body.





The RS bucket seats are a special feature of the Audi RS 4. They were developed specially for it and combine the characteristics of a racing seat with the benefits of a comfort seat. They are extremely light,

have variable adjustment and are so comfortable on long journeys that you always arrive relaxed. Thanks to its extraordinary lateral stability the Audi RS 4 fulfills all safety standards even without side airbags.

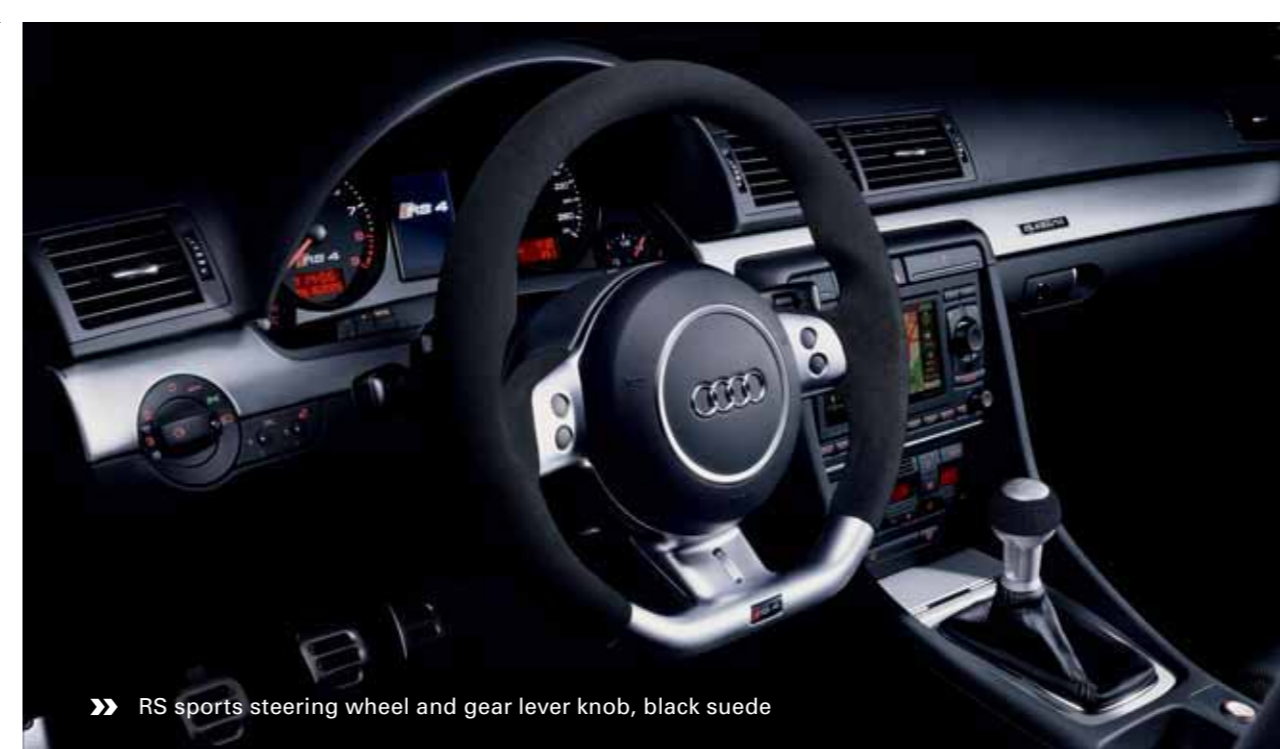

» RS sports steering wheel and gear lever knob, black suede



» The Audi RS 4 is started using the engine start button



» Audi exclusive RS 4 package, black/goya yellow

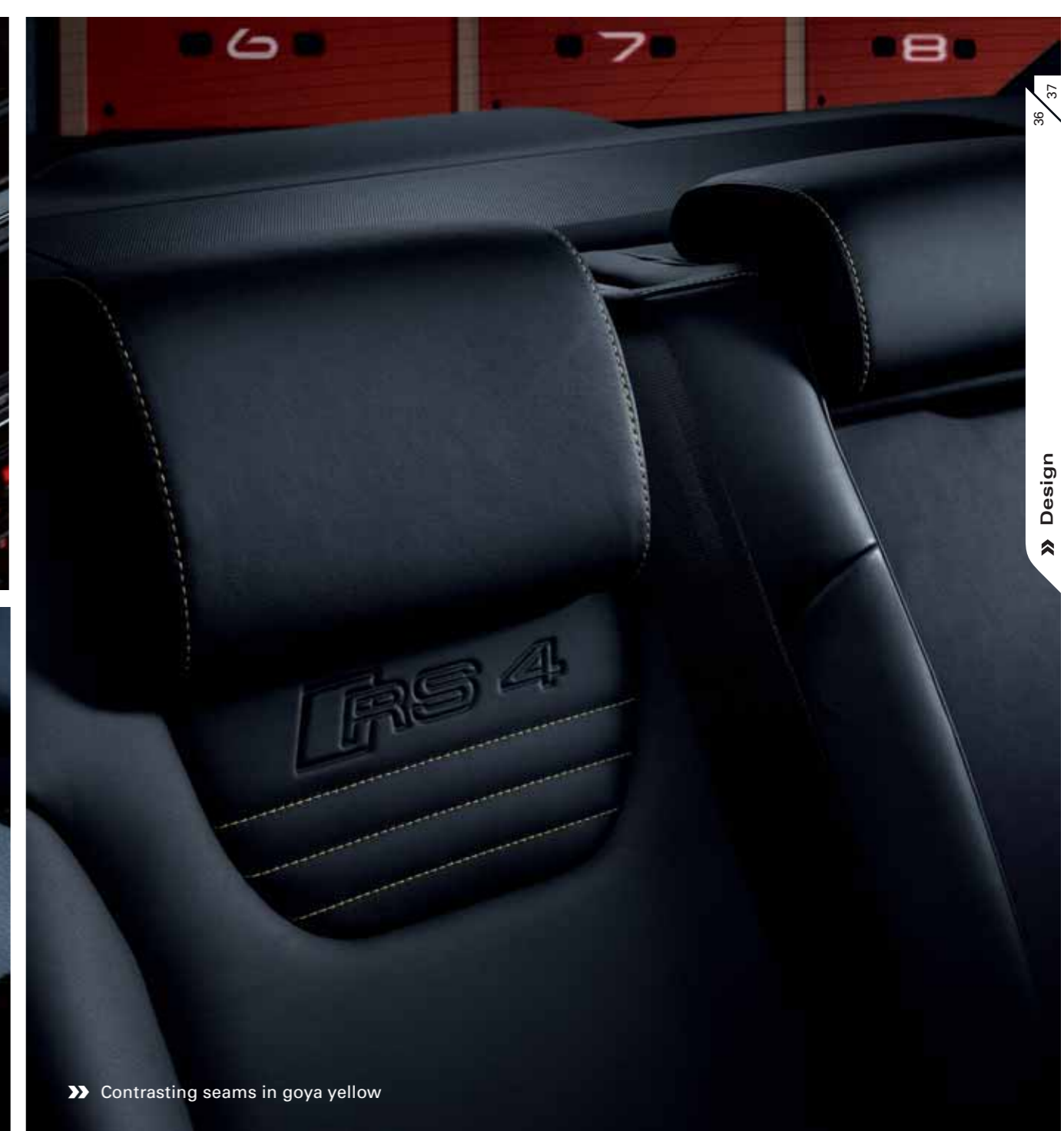

» Contrasting seams in goya yellow





Some experiences are only impressive the first time.
While others never fail to impress.

The long straight is stretched out in front of you.
You push the engine starter button. Accelerate again.

Feel that thrust again. Master those cornering forces.
Every day ideally. What are you waiting for?



Paints

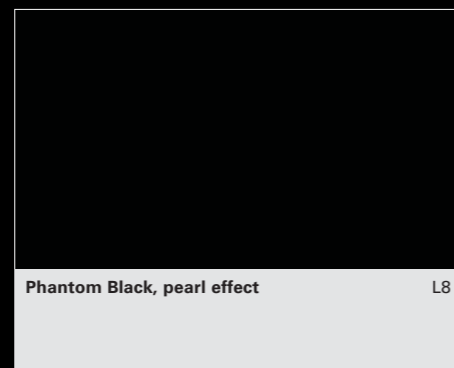
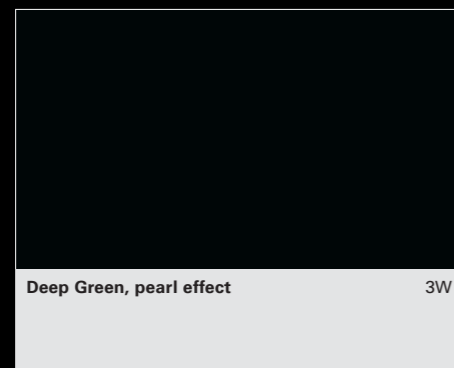
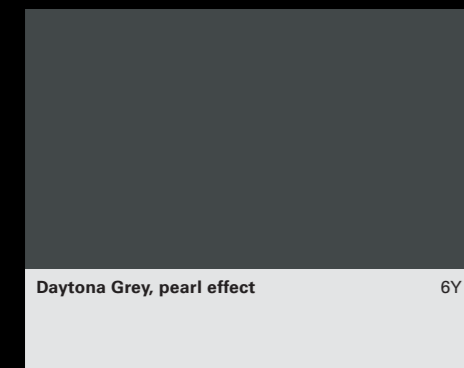
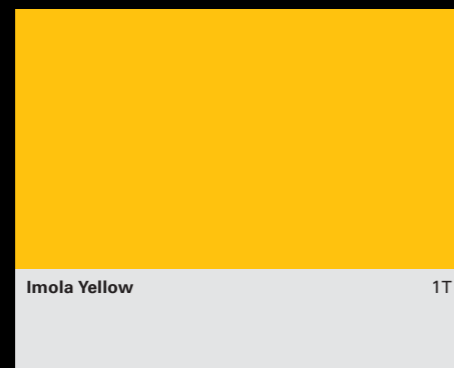
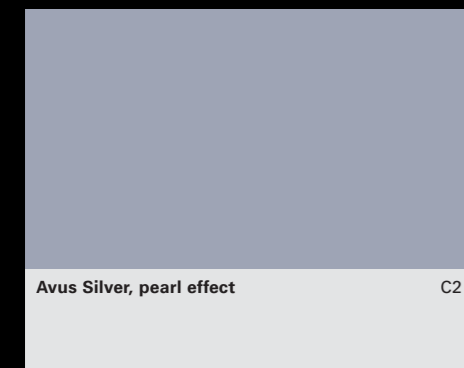
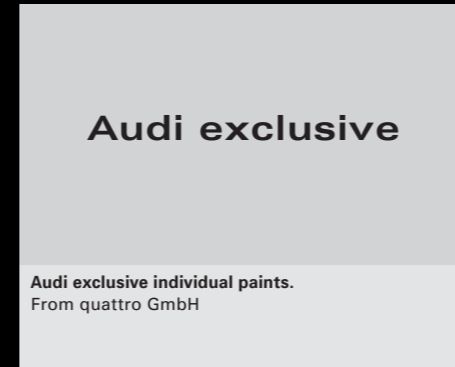
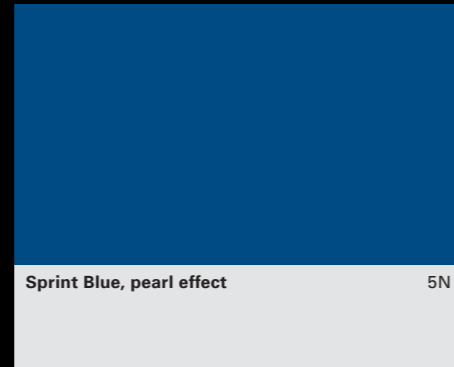

RS bucket seat/sports seats

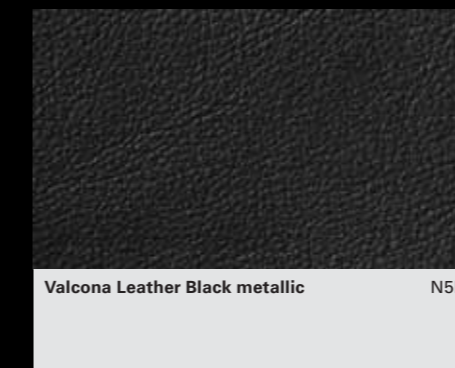
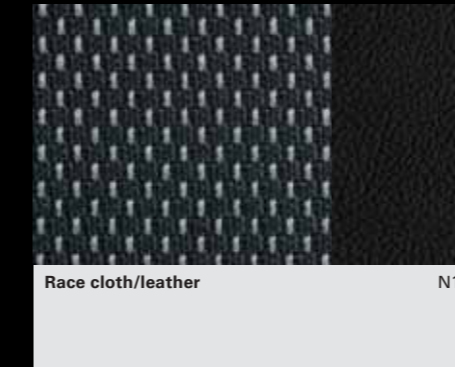

Sports seats



Please find out from your local Audi partner which equipment is standard and what optional equipment is available in your country.

Inlays



Carbon 5MN



Fine grain myrtle Nutmeg 5MR



Brushed aluminium matt 5TG

Audi exclusive

Audi exclusive inlays.
From quattro GmbH

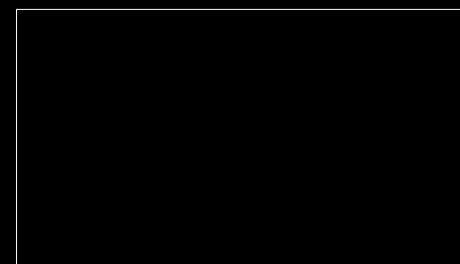

Piano finish Black 5TL

Wheels



Cast aluminium wheels in 5 spoke styling,
size 8.5 J x 18 with 255/40 R 18 tyres



Cast aluminium wheels
in 7 double-spoke styling,
size 9 J x 19 with 255/35 R 19 tyres

Equipment

Equipment packages

Audi exclusive package comprising

- Circumferential and decorative seams in contrasting colour around head zone
- Floor mats with matching coloured piping
- Rear seat in Valcona leather, black with contrasting coloured seams
- RS bucket seats, Valcona leather, black
- Seat side bolsters of front seats in perforated leather in contrasting colour
- Steering wheel rim and gear lever gaiter, black leather with coloured seams
- The package is available in Black/Goya Yellow, Black/Crimson Red and Black/Silver

Luggage compartment package (saloon) comprising

- Combined net
- Net on the right-hand side of the luggage compartment
- Socket (12 V)

Luggage compartment package (Avant) comprising

- Combined net
- Tensioning straps on the right-hand side of the luggage compartment

Comfort package comprising

- Centre armrest, front, with storage compartment, hinged
- Cruise control system
- Floor mats, rear
- Loudspeakers with BOSE sound system
- Rear windows, electric
- Seat heater for front seats
- Through-loading facility with ski bag

Styling package comprising

- Exhaust tailpipe, twin oval tailpipes, Matt Black
- Exterior trim in rear bumper in vehicle colour (saloon)
- Exterior trim on roof frame and window capping rim, Matt Black
- Radiator grille frame, highly-polished, Black
- Roof rails, Matt Black (Avant)

adaptive light including Xenon plus; dynamic cornering light achieved with swivel headlights

Air recirculation control, automatic, for the automatic comfort air-conditioner (uses an air quality sensor)

Airbags

Front passenger airbag deactivation, see ISOFIX child seat mounting

Fullsize-airbag for driver and front passenger, two-stage deployment depending on severity of impact, sideguard head-level airbag system

Rear side airbags in addition to side impact protection in doors

Ambient temperature display

Anti-lock braking system (ABS) with **electronic brake force distribution (EBD)** and **hydraulic Brake Assist**

Anti-theft alarm system includes interior monitoring and anti-tow away protection

Audi parking system, front and rear

Automatic comfort air-conditioner with sunlight-dependent control, separate temperature control for driver and front passenger seats plus dust and pollen filter

Battery boosted (520 A)

Belt force limiters, front

Belt tensioners, front, pyrotechnic

Body, galvanised (fully galvanised in areas at risk from corrosion)

Brake lining wear indicator

Braking system: 18-inch high-performance braking system with ventilated perforated brake discs

Centre armrest, front, on the tunnel console, with hinged storage compartment

Centre armrest integrated into the rear seat back, with first-aid kit

Childproof safety locks on rear doors

Cool box in glove box, cooled during the journey by the automatic comfort air-conditioner

Cruise control, electronic

Decorative inlays

Brushed matt aluminium

Carbon

Piano finish Black

Fine grain myrtle Nutmeg

Door catches in RS styling on the inside

Door reflectors, active

Double glazing, improves outside noise insulation and extra vehicle security

Driver information system with colour display

Electric windows

Rear windows, electric (standard front) individually or centrally controlled from driver's seat, childproof safety locks for rear windows

electrically operated at the front, with safety system to limit closing force, one-touch opening/closing function with convenience switches

Engine start button on the tunnel console

ESP Electronic Stabilization Programme, two settings, including **electronic differential lock (EDL) traction control (ASR)**

Exhaust tailpipe, twin oval tailpipes

Exterior mirrors

RS exterior mirror in double arm design, housing in matt aluminium finish, electrically adjustable and heated, without folding function, with aspherical mirror glass on the driver's side and convex mirror glass on the passenger's side

automatically dimming

automatically dimming with memory function (available to order with automatically dimming interior mirror only) flat mirror glass on the driver's side

Exterior mirrors with electric fold function, electrically adjustable and heated

electrically folding, automatically dimming

electrically folding, automatically dimming with memory function (available to order with automatically dimming interior mirror only)

flat mirror glass on the driver's side

with choice of flat or aspherical mirror on the passenger side

Exterior mirrors with electric folding function

Floor mats, front and rear

Fog lights (halogen)

Front bumper, RS styling

Front windows, electric, safety system to limit closing force, one-touch opening/closing function with convenience switches

Garage door opener (HomeLink), programmable radio-operated remote control, incorporated into the sun visor

Gear lever knob in perforated leather, aluminium-look

Glove box, illuminated and lockable

Headlight cleaning system

Head restraints for all seats

Heat-insulating glass, green

Immobiliser

Infotainment/Navigation systems

Navigation system with MMI control logic¹: navigation CD (if digitised), 6-inch monochrome display in the centre console for input of destination and description of route, dynamic route guidance to destination, radio with twin tuners, CD player for navigation CD, audio or MP3 CD (not when navigation system is being used at the same time), aerial diversity, arrow indication in driver information system, including driver information system and aerial

Navigation system plus with MMI control logic: including navigation CD, 6 inch TFT colour screen with 3D map display, dynamic route guidance, radio with twin tuners, DVD player for navigation DVD, audio or MP3 CDs (not when navigation system is being used), two integral MMC/SD card slots for MP3, alternative route calculation. Find out from your Audi partner about digitised countries.

Voice control system for navigation system plus: In conjunction with the optional multifunction steering wheel, the main basic functions for the navigation system, radio, CD, mobile phone fittings and CD changer can be operated by voice control.

TV receiver for Navigation system plus, suitable for receiving analogue television stations, including teletext (can only receive programmes when vehicle is stationary; can only be ordered with Navigation system plus)

Infotainment/Radios

concert radio with CD player, MP3 capability, loudspeakers front and rear, bass loudspeaker and centre loud-speaker, total output 150 watts, aerial diversity

symphony radio with integral 6xCD changer, MP3 capability, with TP memo function, loudspeakers front and rear, bass loudspeaker and centre speaker, total output 150 watts, aerial diversity

BOSE Sound system with a total of 10 BOSE high-performance loudspeakers, specially adapted acoustics and dynamic driving noise compensation, total output 190 Watts

CD changer for 6 CDs, in the glove box

Audi exclusive iPod interface, console in glove compartment; some iPod functions can be operated from the radio or multifunction leather steering wheel (if ordered at same time); console charges battery when in use

Infotainment/Telephone

Mobile phone fittings with hands-free facility on the centre console to the right next to the radio, dual band (D and E networks), voice activation, control via multifunction sports leather steering wheel (where ordered with package), Bluetooth interface; wireless adapters (also required for Bluetooth phones) and information about compatible mobile phones can be obtained from your Audi partner.

Mobile phone fittings in the centre armrest including front centre armrest, like mobile phone fittings with hands-free facility (available to order in conjunction with the multifunction sports leather steering wheel only)

Interior lighting package

Interior lighting with reading lights, front and rear

Interior mirror

Interior mirror, automatically dimming, with light/rain sensor to control the automatic lights-on facility, the coming home/leaving home function and the automatic windscreen wiping function

Interior mirror with digital compass display (can only be ordered in conjunction with automatically dimming interior mirror)

ISOFIX child seat mounting kit for outer rear seats

Lashing eyes in luggage compartment

Luggage compartment cover (Avant), single handed operation

Luggage compartment, velour (Avant)

Pedals, aluminium look

quattro[®], permanent all-wheel drive with asymmetric/dynamic torque distribution

Radiator grille, lozenge design

Radio-controlled clock

Radio remote control for central locking

Rear bumper, RS styling

Rear seat can be split and folded down 1/3 or 2/3

Rear spoiler (saloon) in vehicle colour, integrated into the body

Rear window wiper (Avant), with automatic wash/wipe function

Rev counter

Reversible mat (Avant) in luggage compartment, velour/rubberised on one side, fold out for entire loading surface including when rear seat backrest is folded down, with unfolding cover for loading sill and bumper

Roof edge spoiler (Avant)

Roof rail, aluminium matt (Avant)

Roof rail, in matt black (Avant)

RS 4 logo in radiator grille, on rear door protective side mouldings, in sill trims, on the tailgate, on the RS sports steering wheel, in the rev counter and on the seat covers

Seat belts, three-point automatic, height adjustable at front

Seat covers

Silk Nappa leather trim: seat covers, head restraints and door trim (inner panels) in leather Silk Nappa, seats and head restraints with pipping in contrasting colour

Seat covers, Race fabric/leather

Valcona leather trim: seat covers, head restraints and door trim (inner panels) in Valcona leather

Seats

RS bucket seats at front, manually adjustable, electrically adjustable lumbar support, width of seat cushion and seat back electrically adjustable, no side airbag

Sports seats at front, front seats electrically adjustable, include Audi backguard (in the event of a rear-end collision, the seats are designed to hold the upper body in position and support the head in good time; this increases the level of protection and helps reduce the risk of whiplash injuries)

Memory function for the electrically adjustable driver's seat and exterior mirror (available to order in conjunction with sports seats at front and exterior mirrors with memory function only)

ISOFIX child seat mounting, standard mountings for front passenger seat and outer rear seats, including deactivation switch for passenger airbag (available to order in conjunction with front sports seats only)

Seat heaters for the front seats, steplessly variable heating of seat cushions, backrests and side bolsters

Seat heaters for the front and rear seats, steplessly variable heating of seat cushions, backrests and side bolsters at the front and the outer seat cushions in the rear

Self-locking centre differential, with asymmetric/dynamic torque distribution

servotronic, speed-sensitive power steering

sideguard head-level airbag system

Side impact protection

Sill extensions

Sill trims in door sills with **RS 4 logo**

Sliding roofs

Glass sliding sunroof, electric with steplessly adjustable sun protection

Solar sliding sunroof, electric with integrated solar cells for continuous airflow when vehicle is parked

Socket (Avant), 12 V, in luggage compartment

Sports suspension with variable damping (Dynamic Ride Control DRC)

Steering wheel adjustment for height and reach

Steering wheels

RS Sports steering wheel in perforated leather with inserts in aluminium finish, 3-spoke design, flattened at bottom

Multifunction sports leather steering wheel, 3 spoke styling, for operating Audi radio systems and/or mobile telephone

Sunblind (Avant), manual for rear door windows

Sunblind (saloon), electric for rear window, manual for rear door windows

Tailgate, automatically opening (saloon): when unlocked the tailgate opens automatically

Through-loading facility with ski bag

Tinted windows (Avant), rear window, rear door windows and rear side windows

tire mobility system, with 12V compressor and tyre sealant

Tyre pressure monitoring system

Vehicle tool kit in luggage compartment

Wheels and tyres

Cast aluminium wheels in 5-spoke styling, size 8.5 J x 18 with 225/40 R 18 tyres

Cast aluminium wheels in 7-double spoke styling, size 9 J x 19 with 255/35 R 19 tyres

Cast aluminium wheels in 7-double spoke styling, titanium look, size 9 J x 19 with 255/35 R 19 tyres

Cast aluminium winter wheels in 5-spoke styling, size 7.5 J x 18 with 225/45 R 18 tyres

Cast aluminium winter wheels in 7-double spoke styling, size 8 J x 19 with 235/40 R 19 tyres

Cast aluminium winter wheels in 7-double spoke styling, size 9 J x 19 with 255/35 R 19 tyres

Wheel arch extensions front and rear

Windscreen wipers and cleaning system: two speeds, 4-speed adjustable intermittent wipe

Xenon plus headlights including daytime driving light

Audi exclusive
Audi exclusive controls, leather
Audi exclusive floor mats with leather piping
Audi exclusive individual paint
Audi exclusive inlays
Audi exclusive leather trim (Package 1), Pearl Nappa leather, black/Alcantara coloured
Audi exclusive leather trim (Package 1), Valcona leather
Audi exclusive leather trim (Package 2), Valcona leather
Audi exclusive seat belts
Audi exclusive steering wheel rim, leather

Audi exclusive carpet
RS 4 Sport
Ceramic braking system, at front ¹ , perforated brake discs made from carbon fibre reinforced ceramic, with specially developed cooling passages, ventilated; 6-piston monoblock aluminium brake callipers in anthracite with "Audi ceramic" logo; maximum braking power and fading stability, extremely long service life, increased driving dynamics and agility, designed for sports use and maximum demands, e.g. on the race track; note: only in combination with 19-inch wheels
Floor mats with RS 4 logo , black, with stitching on front floor mats and piping in black or silver
RS Sports steering wheel in suede , suede covered steering wheel rim, gear lever knob and handbrake grip
Sports suspension plus , stiffer spring/damper setting, 10 mm lower suspension compared to standard Sports suspension
Sports tyres : cast aluminium wheels in 7-double spoke styling, size 9 J x 19 with high performance sports tyres 255/35 R 19, extra set of wheels for racing track use or driver safety training; street-legal with certain restrictions regarding wet handling

Model	RS 4 Saloon	RS 4 Avant
Engine type	V8 petrol engine	V8 petrol engine
Displacement cc (valves per cylinder)	4163 (4)	4163 (4)
Max. output, kW (hp) at rpm	309 (420)/7800	309 (420)/7800
Max. torque, Nm, at rpm	430/5500	430/5500

Driveline/Wheels		
Layout	quattro® permanent all-wheel drive	quattro® permanent all-wheel drive
Transmission	6-speed manual transmission	6-speed manual transmission
Wheels	Cast aluminium wheels, size 8.5 J x 18	Cast aluminium wheels, size 8.5 J x 18
Tyres	255/40 R 18	255/40 R 18

Weights/capacities		
Unladen weight ¹ kg	1650	1710
Gross vehicle weight kg	2200	2260
Roof load/trailer nose weight in kg	75	75
Fuel tank approx. l	63	63

Performance/consumption ²		
Top speed ³ in km/h	250	250
Acceleration 0–100 km/h in s	4.8	4.9
Fuel grade	SuperPlus unleaded 98 RON ⁴	SuperPlus unleaded 98 RON ⁴
Fuel consumption ⁵ in litres/100 km	urban	urban
	extra-urban	extra-urban
	combined	combined
CO₂ emissions ⁵ in g/km	innerorts	innerorts
	extra-urban	extra-urban
	combined	combined
Emissions standard	EU4	EU4

- Notes**
- ¹ Vehicle unladen weight without driver (calculated in accordance with the current version of Directive 92/21/EEC). Optional equipment may increase the car's unladen weight and drag coefficient, whereby the possible payload limit and top speed will be reduced accordingly.
 - ² The fuel consumption and CO₂ emissions of a vehicle depend not only on the efficient utilisation of the fuel by the vehicle, but also on driving behaviour and other non-technical factors. CO₂ is the greenhouse gas that is primarily responsible for global warming.
 - ³ Regulated
 - ⁴ SuperPlus unleaded (98 RON) is recommended. If unavailable, use Super unleaded (95 RON); power output will be slightly reduced.
 - ⁵ The figures given have been calculated in accordance with the specified measuring procedures (current version of Directive 80/1268/EEC). The figures do not refer to one individual vehicle and do not form part of any offer, but rather should be used purely for purposes of comparison between the different vehicle models.

Important note
Inspections are due as shown on the service display.

Dimensions RS 4

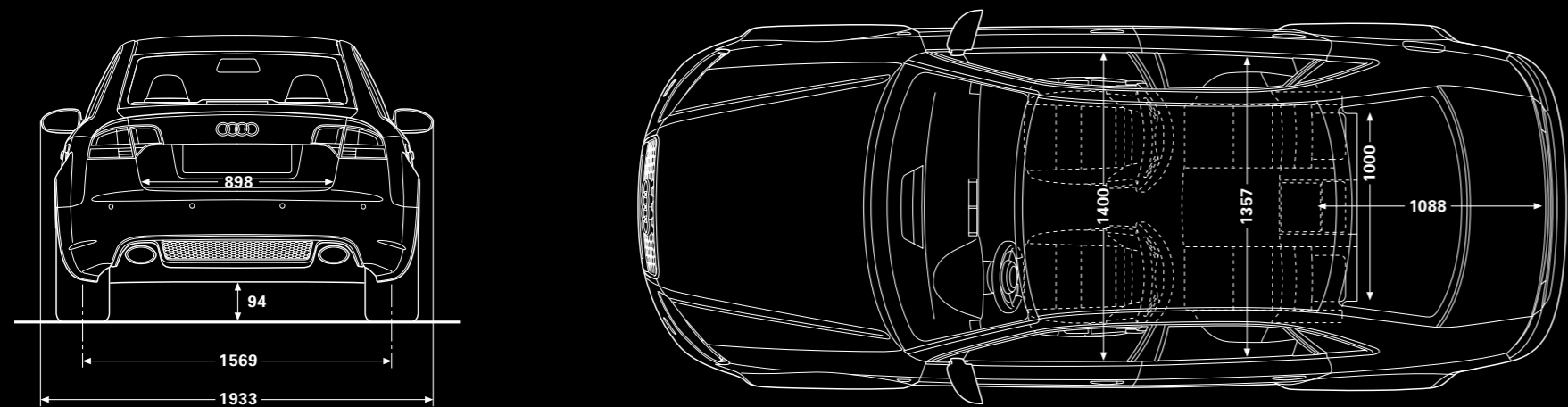
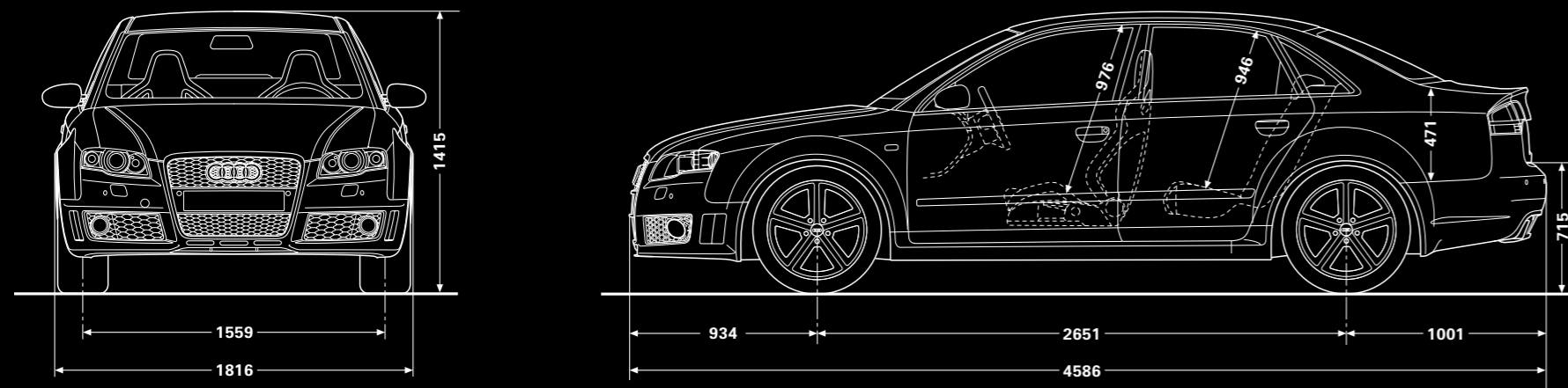

Dimensions in millimetres.

Dimensions were measured with vehicle at unladen weight, ground clearance measured with vehicle carrying its maximum load.
Luggage compartment volumes 460/833 litres (measured by the VDA standard test method using 200 x 100 x 50 mm blocks; second value with rear seat folded down).
Turning circle approx 11.1 m.

Dimensions RS 4 Avant

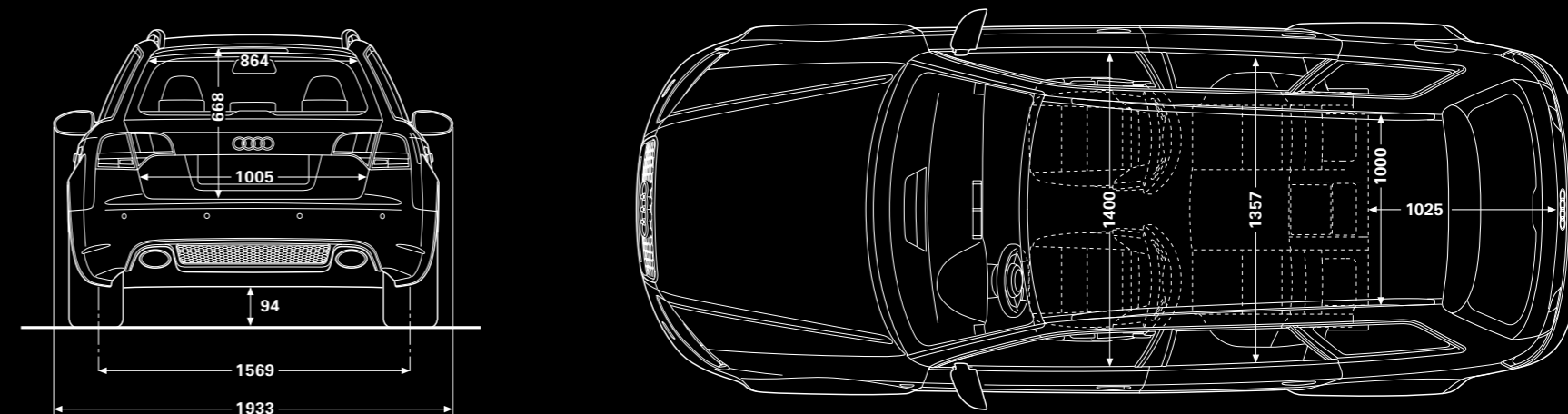
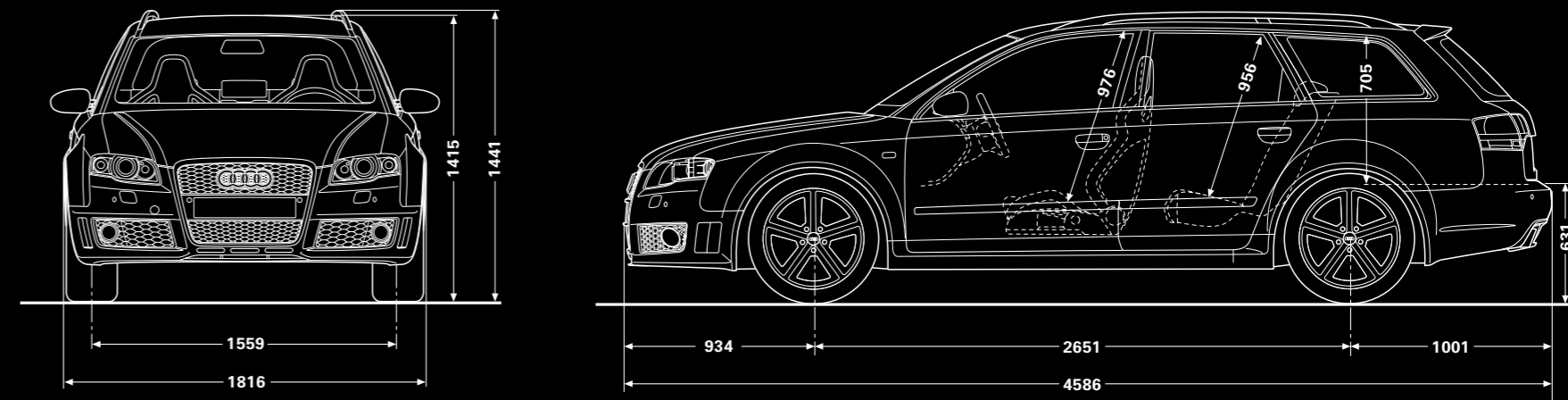

Dimensions in millimetres.

Dimensions were measured with vehicle at unladen weight, ground clearance measured with vehicle carrying its maximum load.
Luggage compartment volumes 442/1354 litres (measured by the VDA standard test method using 200 x 100 x 50 mm blocks; second value with rear seat folded down).
Turning circle approx 11.1 m.

Vorsprung durch Technik www.audi.com

The models and equipment versions illustrated and described in this brochure and some of the services listed are not available in all countries. Some of the cars illustrated are equipped with optional equipment for which an extra charge is made. Details concerning the delivery specifications, appearance, performance, dimensions and weights, fuel consumption and running costs of the vehicle were correct to the best of our knowledge at the time of going to press. Deviations from the colours and shapes shown in the illustrations may occur. No liability is accepted for errors and printing errors. The right to introduce modifications is reserved. Not to be reproduced, including in part, without the written approval of AUDI AG.

This brochure is printed on paper made from pulp bleached without the use of chlorine.

AUDI AG
85045 Ingolstadt
www.audi.com
Valid from September 2006

Printed in Germany
658/1142.00.18