



R8

Audi R8 Coupé | R8 Spyder

 **Audi Sport**
performance cars





	Page	
Fascination		
	4	History
	6	Manufacture
	8	The Audi R8 Coupé experience
	30	Outlook Audi R8 LMS
	32	The Audi R8 Spyder experience
Technology		
	54	FSI®
	58	quattro®
	60	Audi magnetic ride
	62	Audi Space Frame (ASF)
	64	Hood, belt microphone
Equipment		
	68	Audi exclusive
	70	R8 luggage sets
	72	Style guides Audi R8 Coupé
	74	Style guides Audi R8 Spyder
	76	Paints, sideblades, hood colours
	78	Seats/seat covers
	80	Leather upholstery and trim, headlining/hood headlining
	82	Inlays
	83	Wheels/tyres
	84	Lights and mirrors, exterior equipment
	86	Interior equipment
	88	Infotainment
	89	Assistance systems, technology
	91	Audi extended warranty
Miscellaneous		
	92	Technical data
	94	Dimensions
	96	Index
	100	Fascination Audi

The equipment for the vehicles illustrated can be found on page 99.
The fuel consumption and CO₂ emission figures can be found on page 92.

The experience from over 70 years in motorsport.

The Audi name has been an integral part of motor racing for many years. From the success enjoyed by Auto Union in the 1930s, through the manufacturers' world rally championships and the touring car victories of the 80s and 90s and right up to the present day – our engineers have continually found ways of setting new standards in motorsport.

Since 1999, it has been the drivers with the four rings that have been demonstrating in the legendary Le Mans 24 Hours that the motto "Vorsprung durch Technik" is a lot more than just a promise. With five overall victories in the toughest long-distance race in the world and more than 60 victories at international races, the Audi R8 sport prototype, equipped with the direct fuel injection technology FSI®, has been the most successful Le Mans racing car of all time. Since 2006, Audi uses the TDI technology in motor racing with which Audi was able to celebrate the fourth triple triumph of the Audi brand at the long-distance classic in Le Mans in 2010.

Technologies that have been tested under the most severe conditions during racing and the experiences gained from it have consequently been implemented for the development of the Audi R8. The Audi R8 LMS which is used in customer sport extremely successfully since 2009 proves that the result was an excellent overall concept with particularly sporty talents.

The Audi R8. Whether Coupé or Spyder, in either case with the genes of a winner: "Gentlemen, start your engines!"





The implication of relying on craftsmanship.

To create a truly unique car you need a very special tool: the human hand. Unlike in large-scale productions with fully automated processes, the production of the Audi R8 is a pure manufacture. For example, the 99 metres of weld seam of the bodyshell is mostly manually created. Small, highly qualified teams give the super sports car its unique shape within 72 hours. The most experienced employees assemble the R8 on 14 coordinated stations almost exclusively by hand. Due to the numerous equipment variants and customising possibilities hardly any combination is created twice.

After completion, each car undergoes demanding quality control, because precision is top priority at Audi. From the detection of surface unevenness and checking of the extremely narrow clearances to the detailed road driving test – we only have one goal: to create an absolutely unique vehicle together.

Each Audi R8 is unique and therefore bears a very personal style.









Born of powerful ideas.

Designing a top-end sports car is one of the greatest challenges in car design. It is where technical precision and performance are stretched to the very limits of feasibility. In the Audi R8, our designers and developers have succeeded in creating a car which in every respect embodies our striving for automotive perfection.

R8

Audi R8 Coupé

The design of the Audi R8 Coupé makes a clear statement. Its muscular, clearly structured contours emphasise the fascination with the car's origins – namely motorsport. Its exciting stylistic line makes a promise – powerful, irresistible dynamics –, which the car honours effortlessly.

The contrasting-colour sideblades behind the doors highlight the lateral air flow and lend the R8 Coupé a unique dynamic character. The large air outlets, interplaying with the slimline LED rear lights, give the rear of the car a very powerful, broad appearance.

The exhaust system with dual-branch tailpipes rounds off the impressive looks of the R8 Coupé 4.2 FSI quattro.









The Audi R8 bears the four rings on its bonnet. These, together with the large air intakes and the slim, sporty Audi Singleframe leave you in no doubt: you are looking at a performance-oriented sports car.

The rear spoiler is automatically extended at 100 km/h and is retracted sleekly back into the vehicle silhouette at 35 km/h. If desired, the spoiler can also be operated manually by pressing a button.

The headlights with LED daytime running lights give the R8 Coupé 4.2 FSI quattro a striking appearance. The characteristic rear lights are also LED technology and represent the optimum in engineering expertise.

The design of the Audi R8 Coupé 5.2 FSI quattro is a revolution of the performance concept. Its greater power is evident right from the first glance. The looks of the high-gloss black painted radiator grille with distinctive chrome-look fins radiate sporting dominance. This impression is only strengthened by the front headlights with full LED technology and the front spoiler edge, painted in high-gloss black. Flared sideblades channel the air directly to the powerful 5.2 litre high-speed engine located towards the rear. Extended sills and the V10 emblem on the front hood underline its distinctive presence.



The fuel consumption and CO₂ emission figures can be found on page 92.





A diffuser painted in high-gloss black, deep-set black rear lights and the oval tailpipe trims of the dual-branch exhaust system give the rear portion an unmistakable charisma.

The aluminium look air outlets on the left and right of the rear window form the perfect frame for the heart of the Audi R8 Coupé 5.2 FSI quattro: the V10 mid-engine.

The polished two-tone 19-inch, 10-spoke Y design forged aluminium wheels round off the exclusive appearance of the Audi R8 Coupé 5.2 FSI quattro.





R8

HH MF 442

The expertise to bring motorsport technology to the road.

The monoposto cockpit is reminiscent of the typical shape of a cockpit for racing cars. Clearly arranged and geared to the driver, it convinces with perfected ergonomics and intuitive operability. Like everything else in the R8, the leather-covered multifunction sports steering wheel in 3-spoke design with a flattened steering wheel rim base and the standard sports seats radiate pure sportiness. It goes without saying that the finish is top quality.









The instrument cluster and the gear lever knob in V-10 specific design let you know that you are driving a top performance sports car. Experience how your steering commands are carried out with absolute precision. Challenge the performance capabilities of the V10 mid-engine. You will be rewarded with a driving experience that is usually only reserved for racing drivers. And so that you are able to enjoy every corner, the Fine Nappa leather sports seats in the R8 Coupé 5.2 FSI quattro provide excellent lateral support. A host of storage facilities, high-quality materials and a wide selection of customisation options complete the high-quality interior.

The fuel consumption and CO₂ emission figures can be found on page 92.



The fuel consumption and CO₂ emission figures can be found on page 92.



The desire to give free rein to power.

This car has racing genes. And you can feel them on the road. Like practically no other sports car, the R8 Coupé offers the feeling of unmediated control over almost limitless power. So direct and intense, you will feel you are at one with the technology.



The claim to make Vorsprung durch Technik a real liveable experience.

Its design arouses respect. Its technology is ready to take on any challenge.

Experience the superiority of your Audi R8 Coupé:
you won't get any closer to the racetrack whilst on the road.









The conviction
that a drive in the R8 will say more than a thousand words.





The motivation to combine motorsport and standard production.

With the Audi R8 LMS, the R8 returns to the racing track: 54% of its parts are based on the R8 Coupé 5.2 FSI quattro, including the Audi Space Frame (ASF), the suspension and last but not least its V10 engine. Built in accordance with the GT3 regulation of the FIA, the R8 LMS offers pure-bred racing technology, high performance and one thing above all: the basis for successful motorsport.

No other GT3 racing car has been more successful in its initial years of deployment: 163 podium results, 64 victories and 7 championship titles prove the impressive performance of the Audi R8 LMS.

The programme from Audi race experience enables you to experience racing sport atmosphere with the R8 LMS first hand – from individual training and acquiring a motorsport licence to participating in a race with a professional team.

Further information about this topic and your personal contact persons concerning the Audi R8 LMS are available at www.audi.com/r8lms and www.audi.com/driving.

R8

Audi R8 LMS





Audi Sport

MICHELIN

Audi quattro GmbH BILSTEIN Eibach





Opening up possibilities – even when closed.

A unique car like the R8 Coupé cannot be improved. However, it may be changed: for new perspectives and even more freedom. Get ready to meet an extraordinary car: Audi R8 Spyder, the open high-performance sports car. Powerful. Dynamic. Extrovert. A spyder which fulfils expectations of performance and the high demands of the Audi brand: to build one of the most breathtaking vehicles of its class.

R8

Audi R8 Spyder



The extended fabric hood with fins emphasises the clearly structured vehicle lines of the Audi R8 Spyder. It can be opened easily at speeds of between 6 and 50 km/h with the touch function – fully automatically in just 19 seconds. After being opened, the folded hood disappears, by taking up only little space, in a flat storage compartment above the engine compartment. In addition to the hood compartment cover made from extremely light carbon fibre, the use of the fabric hood also contributes to minimising the weight of the vehicle.

The fuel consumption and CO₂ emission figures can be found on page 92.









Sovereign performance is our foremost priority.
Yet we have moved it backwards.

The sporty dominance of the front of the Audi R8 Spyder and the powerful and muscular form of the rear will win you over – even when the hood is open. The strikingly formed wings and distinctive trailing edge skilfully draw attention to the Audi R8 Spyder rear. The engine sound emphasises the potential of the mid-engine in an impressive manner.

The fuel consumption and CO₂ emission figures can be found on page 92.







Follows a straight line.
Even in corners.









The characteristic Audi Singleframe signals unrestrained forward thrust. The large air outlets in aluminium look on the hood compartment cover quote the shapes of classic racing cars. The dual-branch exhaust system rounds off this high-performance vehicle in a fitting manner.

The fuel consumption and CO₂ emission figures can be found on page 92.



Above all else, top sporting performances require the right breathing technique.

Extended air inlets stress the suspense of the side view. Muscular sill extensions ensure a sporty appearance.







First you want to look at it for even longer.
Then you never want to get out.





The interior of the R8-typical monoposto look ensures a classic motor racing feeling even in the Spyder. Ergonomically shaped sports seats with high-quality seat covers offer superb lateral hold and the optional R8 leather-covered multifunction sports steering with its more heavily contoured rim sits pleasantly in the hand with maximum grip, especially during sporty driving. The heated rear window can be lowered electrically and also serves as a wind deflector when the hood is open. The Bang & Olufsen Sound System always provides excellent sound quality, no matter whether you enjoy the R8 Spyder open or closed.





The standard wind deflector can be attached quickly and provides additional protection from annoying draughts. The illuminated storage compartment in the rear panel offers space for sun glasses, an iPod, or the optional CD changer.





The polished, two-tone forged aluminium wheels in 10-spoke Y design underline the extravagance of the Audi R8 Spyder 5.2 FSI quattro. The all-LED headlights (standard on the R8 Spyder 5.2 FSI quattro) in futuristic design create a brightness close to that of daylight and are unique in the sports car segment.

The fuel consumption and CO₂ emission figures can be found on page 92.





For the first time, you will be wishing that the journey never ends.

Pure aesthetics: The R8 Spyder 4.2 FSI quattro owes its special elegance to the powerfully defined vehicle body and extended side air inlets. The 4.2 litre mid-engine has 316 kW of power at its disposal and accelerates the car from 0 to 100 km/h in just 4.8 seconds. It will even take you to a top speed of 300 km/h, should you wish to do so. The dual-branch exhaust system with twin tailpipes rounds off this high-performance vehicle. It ensures a dynamic sound and an unmistakable look.







What is the quickest way to
say performance?

HRC.



V10 engine with 5,204 cm³ of displacement

- Maximum torque of 530 Nm at 6,500 rpm
- Maximum power of 386 kW at 8,000 rpm
- Specific power output of 74.2 kW per litre of displacement
- FSI® direct fuel injection with up to 120 bar of pressure
- A high compression ratio of 12.5: 1
- Dry sump lubrication adapted from use in motorsport
- Wide cylinder angle of 90 degrees for low centre of gravity

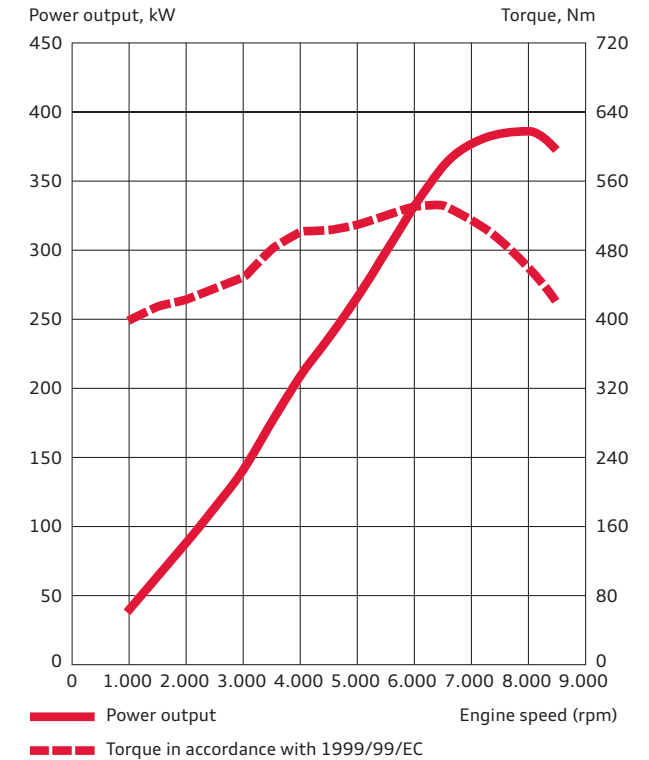

High-revving concept (HRC). The meaning behind this technical term is pure driving enjoyment derived directly from motorsport. The high-rev concept in the V8 and V10 mid-engines of the Audi R8 works according to a simple principle.

An increased number of combustion processes in the cylinders creates more power and therefore a greater power yield. With the V10 engine, for example, the maximum speed is at impressive

8,700 rpm and its maximum power output is 386 kW. Yet, even at low speeds, the long-stroke units drive powerfully forward. The torque curve of the V10 power unit reaches a maximum value of a full 530 Nm. In the R8 Coupé 5.2 quattro, this will enable you to spurt from 0 to 100 km/h in just 3.9 seconds and only 8.1* seconds later you have already reached 200 km/h. The propulsion only ends at 316 km/h. With 4.1 seconds for the spurt from 0 to 100 km/h and a maximum speed of

313 km/h, the R8 Spyder with a 10-cylinder engine variant is almost equal.

The resulting vibrational and thermal stresses are restrained by the compact, high-strength design of the lightweight aluminium engines. In conjunction with the dry sump lubrication used in motorsport, high lateral acceleration forces are also possible. Instead of a conventional deep oil sump, a oil pump module and a separate oil tank ensure that

the oil supply to the engine is even, so that you can fully enjoy every second of the torque and agility of the Audi R8.

* Figure for R8 Coupé 5.2 FSI quattro with R tronic. The fuel consumption and CO₂ emission figures can be found on page 92.



The FSI® principle: continue where others stop.

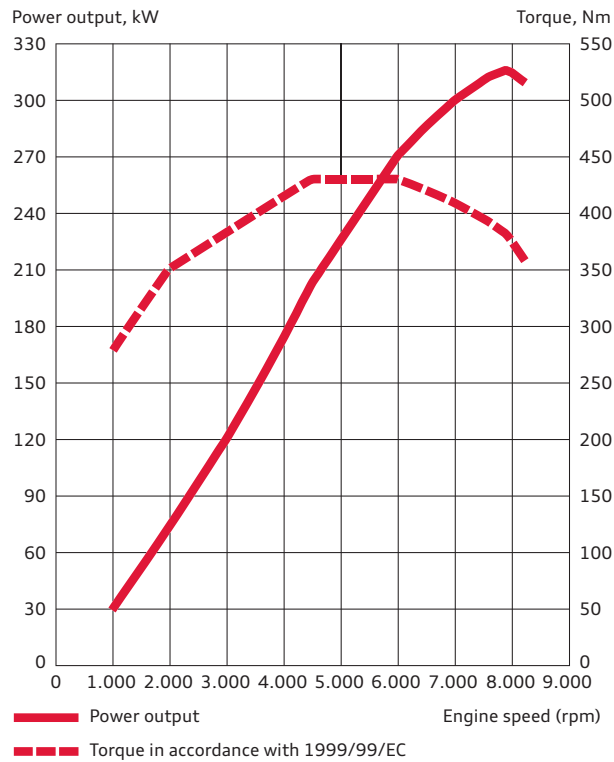

V8 engine with 4,163 cm³ of displacement

- Maximum torque of 430 Nm at 4,500–6,000 rpm
- Maximum power of 316 kW at 7,900 rpm
- Specific power output of 75.9 kW per litre of displacement
- FSI® direct fuel injection with up to 120 bar of pressure
- A high compression ratio of 12.5: 1
- Dry sump lubrication adapted from use in motorsport
- Wide cylinder angle of 90 degrees for low centre of gravity



In addition to the high-rev concept, this is the second component for the irresistible forward movement of the R8 models: FSI®. This fuel injection technology, which we have also brought from the racing track to the road, works in both engine variants.

The FSI technology directly injects the fuel into the combustion chamber where it is highly compressed. This produces a very even fuel/air mixture, leading to particularly efficient

combustion and therefore to a better power delivery and power yield.

The V8 power unit in the Audi R8 reaches its maximum torque of 430 Nm between 4,500 and 6,000 rpm with 90% of the power already being available at a wider speed range between 3,500 and 7,500 rpm. This power lets the R8 Coupé spurt from 0 to 100 km/h in just 4.6 seconds and the R8 Spyder in 4.8 seconds.

Moreover, the mid-engine sports car design means that the mass of the vehicle is concentrated close to its centre of gravity, for very good distribution of axle load and a balanced driving performance. The performance of both engines with their spontaneous responsiveness, the even power delivery and enormous speed willingness is accentuated by a powerful sound backdrop that will thrill you over the entire rev range.



The optional ceramic brake emphasises the proximity of the Audi R8 to motorsport. Its brake discs are produced from carbon fibre reinforced ceramic. With diameters of 380 mm at front and 356 mm at rear, they ensure an excellent deceleration and control, even under high thermal stress – and they are lightweight. Moreover, the enormously firm and abrasion-resistant material increases the service life of the discs.



With quattro®[®], we have developed one of the best all-wheel drive systems in the world.

Try it out: in the Audi R8.

Those who know Audi know quattro®. And once you have driven with quattro, you do not want to drive with anything else. Why? Because this drives brings motorsport to the road in such a convincing way.

quattro is a permanent all-wheel drive. To prevent spinning of the wheels of one axle the drive power is transferred to the other axle. In the Audi R8,

this is achieved by a directly responding multi-plate clutch with optimised control which allows for a variable distribution of the torque between the front and rear axle.

Due to the mid-engine, the quattro in the R8 has been designed with a rear emphasis. The transmission has been placed behind the transversely mounted engine and has a power

take-off which transmits the power to the front axis. This is where the Visco clutch distributes the torques. In the basic design of the drive train, about 15% of the power reaches the front wheels and 85% the rear wheels; if needed, up to 30% are immediately moved to the front. A differential lock on the rear axle further increases the dynamics; its effect is 25% under tension and 45% under thrust. If one wheel of an axle spins,

the electronic differential lock EDS brakes the wheel.

And also in the R8, quattro provides the superior features which have been Audi characteristics for a long time: excellent grip, almost non-slip acceleration, increased handling, improved directional stability – and of course a plus in driving enjoyment.

In the Audi R8 a mid-engine is combined with the proven quattro® technology. The engine power of the R8 can therefore be distributed to all four wheels as required. The permanent all-wheel drive thereby assists active safety, traction and driving dynamics. This means more agile handling and an even more dynamic driving experience on virtually all road surfaces.

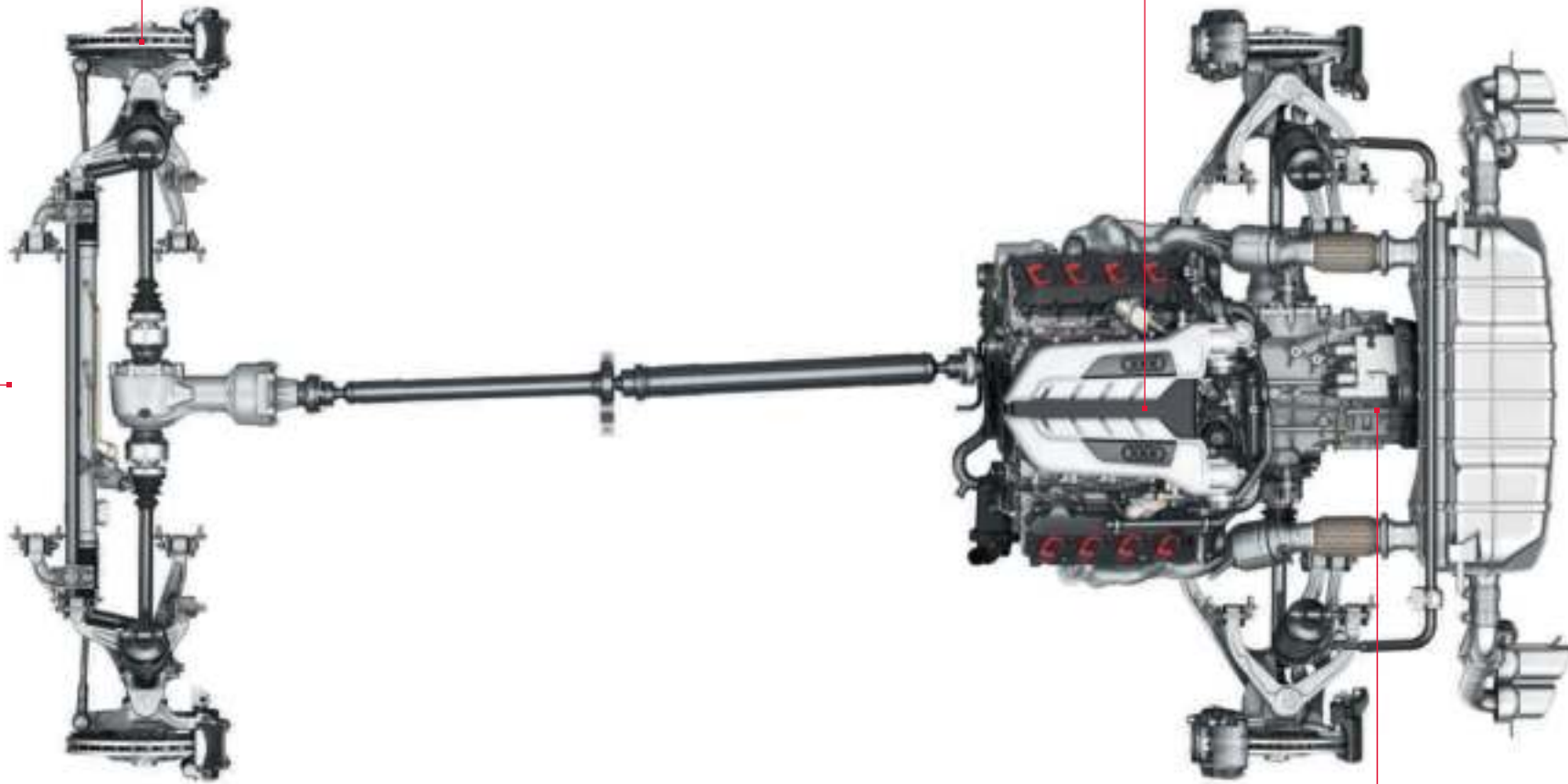

The sequential 6-speed manual transmission R tronic is directly derived from motorsport and is built particularly compact and light. Its shift-by-wire technology enables very short gearshift times. R tronic can be operated by using either the joystick on the centre console or the so-called paddles on the steering wheel - alternatively, you can opt for the automatic mode. And in addition, R tronic offers a sports mode.



Core of the damper is a piston with a magnetic coil. The damper oil runs through the piston which is influenced by a changeable magnetic field. Increasing the flow resistance also increases the damping forces. This is carried out by aligning the iron particles which are contained in the oil along the magnetic field lines.

Our vehicles are often acknowledged to have magnetic appeal.

We use that for the suspension.

The adaptive damper system, Audi magnetic ride, is a very special way to move comfortably and sporty. The system adjusts the firmness of the dampers to the road conditions incredibly fast.

Instead of conventional damper oil, Audi magnetic ride uses a special fluid whose flow behaviour can be changed by an electromagnetic field. Tiny magnetic particles which are contained in the oil

are aligned against the direction of movement of the damper. As a result, the damping force is increased depending on the strength of the magnetic field. Wheel travel sensors and other systems such as steering and ESP inform the magnetic ride control unit about each driving situation and influence the degree of damping within a fraction of a second.

The driver can select one of two basic settings. In the normal mode, the Audi magnetic ride is a comfortable sports suspension which enables relaxed driving even on long journeys. In the sports mode, the suspension transmits direct feedback from the road; the vehicle reacts with even more agility.

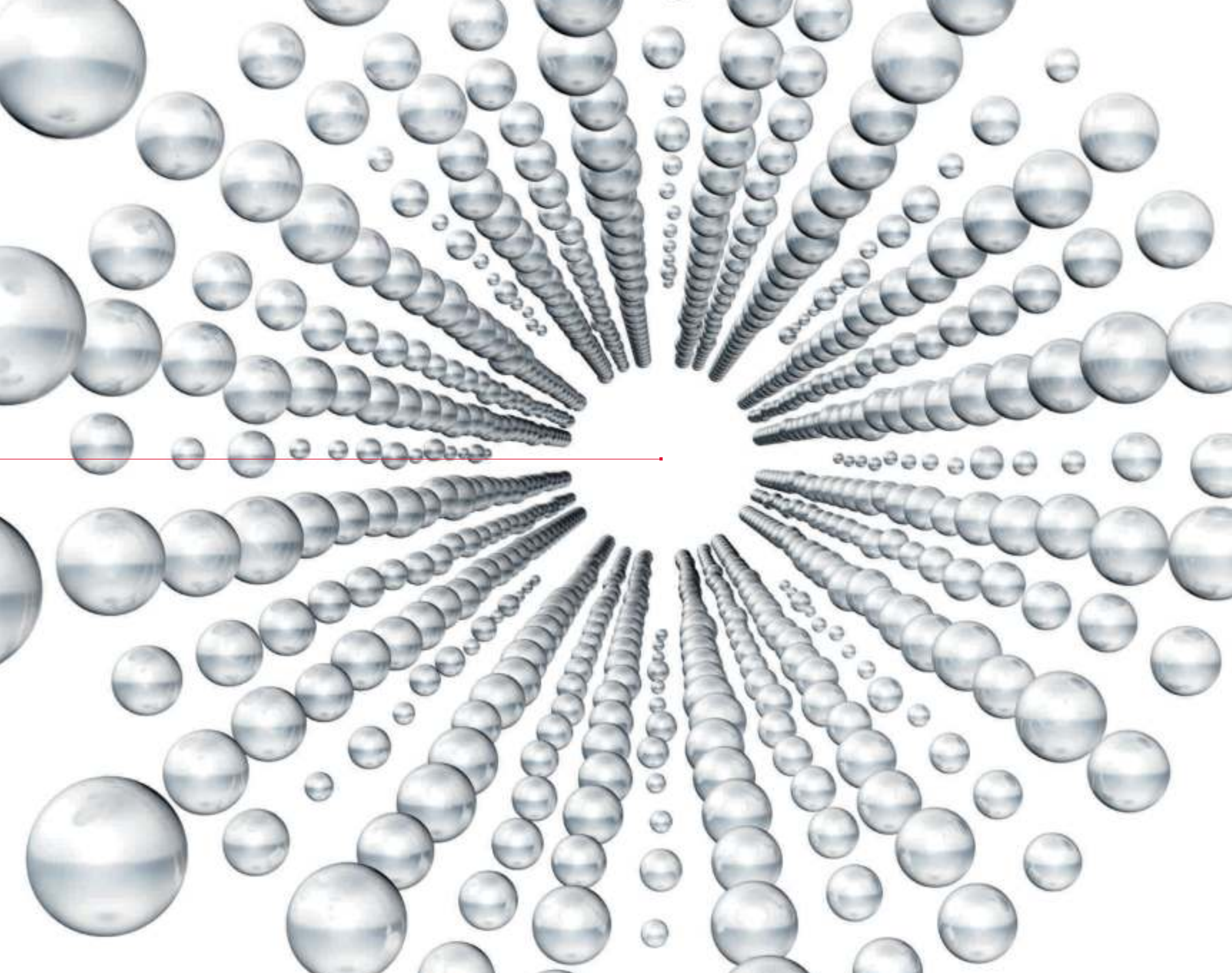

Cast aluminium components: Structural castings provide a high degree of design freedom and function integration. Variable wall thicknesses, flexible shaping and ribbing optimised for the flow of forces ensure that material is only used where it is actually needed. The development of high-strength structural castings establishes the basis for superb integration of extruded aluminium sections into the ASF structure.

Extruded aluminium sections: Thanks to variable wall thicknesses, profiled cross sections and the use of high-strength alloys, extruded profiles enable a very rigid vehicle body to be achieved. They also facilitate excellent energy absorption in the deformation zones. They reveal their full potential in the optimum integration of the castings to form part of the structure, thereby enabling the high performance of the ASF structure

Aluminium panels: They supplement the structure formed by the castings and the profiles and increase overall body rigidity with transition points optimised for force flow, simultaneously combined with superb individual part performance. Thanks to thermally-hardened alloys, they unite optimum function with low weight. The correct choice of joining technology also plays a key role here. Only if this is right will the individual parts be integrated into the ASF to form part of the structure and thereby perform a load-bearing function.

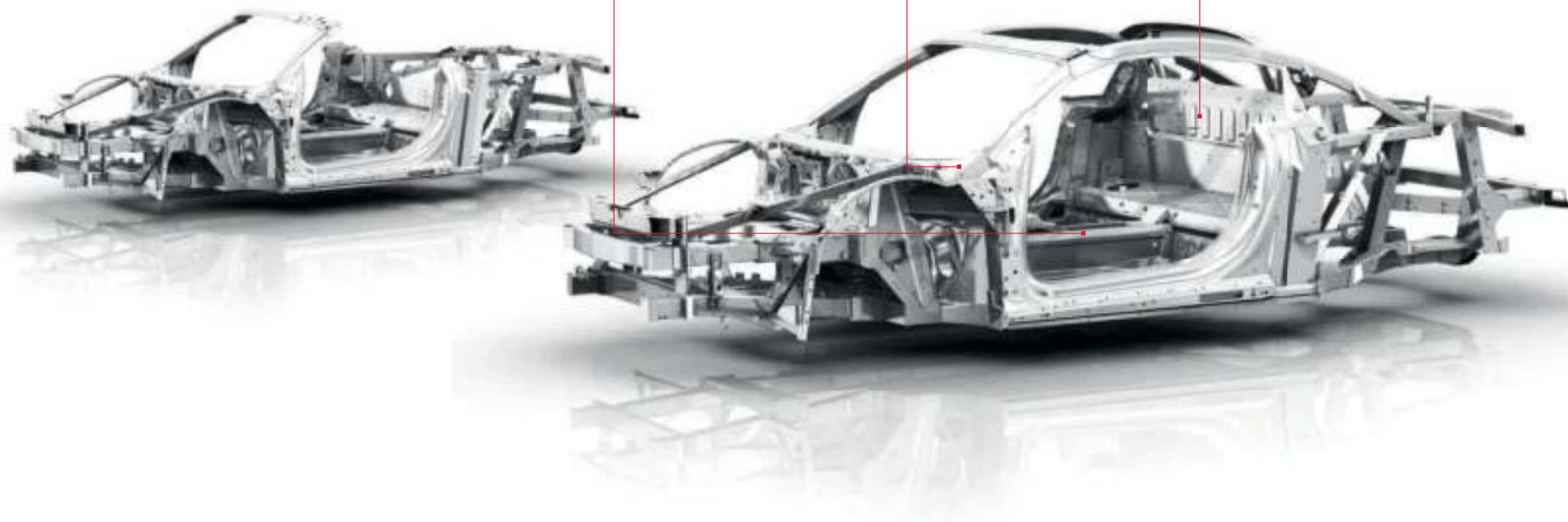

Why an aluminium body?

Because the advantages of lightweight construction are overwhelming.

The aluminium in the Audi Space Frame (ASF) is light, offers more flexible design possibilities in cast parts and extruded aluminium sheets than steel and the resulting components are extremely rigid. Processing it, however, is a challenge, because it demands the highest standards.

That is why we founded the Aluminium Centre (today: Audi Leichtbau Zentrum) at our Neckar-sulm site in 1994, where the Development, Product Planning and Quality Assurance departments work closely together. A three-digit number of patents in this field proves our expertise. And others see it the same way: In 2008, the European Patent Office honoured the achievements of the ASF inventors with "European Inventor of the Year".

The development of special welding methods was just one challenge of many which were successfully overcome. That is why we continually develop the lightweight construction further.

In the Audi R8, the innovative combination of aluminium and magnesium materials provides for a lower vehicle weight and balanced weight distribution. Resulting from consequent lightweight construction in the entire vehicle, the R8 sets a standard concerning weight, sportiness and consumption.

And in the R8 Spyder, particularly light carbon fibre reinforced plastic (CRP) is additionally used. Seven strands of carbon fibre put together are only as thick as a human hair. Yet the finished part made from CRP is much more stable than those from traditional materials, and lighter. So CRP is to be found in the Audi R8 Spyder in the side body panels, in the hood compartment cover and in the interior. What this means for you is a high degree of safety, greater performance and improved handling.

Interior: Optional carbon fibre elements set the tone of the high-quality cockpit and emphasize the close relation to motorsport.

Hood compartment cover: the high level of design freedom permitted by CRP is particularly evident in this complex element.

Side panel: the finished CRP part consists of up to 10 layers and is considerably lighter than a comparable metal part..



Over 800 individual parts.
3 years of development, countless test cycles ...



... and all for one push
of a button.

Opening the classic fabric hood of the R8 Spyder should be as easy as possible for you. That is why there is the additional touch function. At speeds of between 6 and 50 km/h, you only need to push a button and in 19 seconds you are driving with the top down. But it took a long way to get to this point. Extremely demanding design specifications and the tight dimensions of the storage space were just some of the challenges to which our designers have found a particularly convincing answer. The complex double Z fold causes 1.7 m² of material and the longest fins of its class to vanish under the striking, aluminium look air

outlet openings completely automatically and space saving. For a breathtaking silhouette, which you can enjoy with closed top again just 19 seconds later.

Worthy of note: thanks to the precise processing and excellent material, the interior acoustics are almost the same as those of a closed coupé. However, if you do not wish to forego that open air feeling, just lower the rear window and enjoy the mighty sound of the mid-engine.



If you want to talk to us about innovation, talk to your belt.

For the improved communication via voice control system or hands-free facility of the optional Bluetooth interface or mobile phone fitting, and in addition to the microphone in the interior lighting module, we have integrated 3 microphones into each seatbelt of the driver and the front passenger. This new position ensures a speaking distance as close as possible of only 10-15 cm and therefore provides much better voice quality and that the speaker can be easily understood – in the R8 Spyder even when the hood is open.







It is the equipment that transforms an Audi into your Audi.



Because nobody knows your taste as well as you do: Audi exclusive.



Each year Audi sells hundreds of thousands of vehicles. Yet they only sell yours once. How is that possible? With the quattro GmbH service, which makes your Audi unmistakable: Audi exclusive. Paint customised to your concept, fine leather, high-quality Alcantara and selected trim; it is these materials and the precise workmanship which give your Audi its own unique personality. Your Audi partner and the customisation studio at the Audi Forum Neckarsulm are awaiting your wishes.



Customisation example in Fine Nappa leather, cognac and black with seams in crimson red

Tailor-made for your tailor-made vehicle – the R8 luggage set.

The R8 luggage set makes optimum use of the space in the R8 and is tailored to your requirements. This set of cases is hand-made in Germany from finest cowhide. It is available in the same colours as the R8 seat leather and has an embossed R8 logo. The handle recesses of the cases are made from real carbon. Colour-contrasting seams and matching lining made from superior textile fibre turn the luggage items into unique elements.



The luggage set for the R8 in finest cowhide in cognac with crimson red contrasting seams. Individually hand-made in every leather colour available for the seats.



Fitting perfectly to the contours of the interior of the Audi R8 Coupé: 2 suitcases from the luggage sets.



The luggage set makes use of the space underneath the bonnet of the Audi R8.

R8 luggage sets

Product descriptions:

Suitcase

leather handle with real Carbon inlay, all-round metal zip, flat front pocket with concealed zipped compartment; 2 interior leather straps, Nardia lining; dimensions: height 37 cm, width 45 cm, depth 17 cm

Briefcase

leather handle with real Carbon inlay, all-round metal zip, flat front pocket with concealed zipped compartment; Nardia lining; inner compartments for laptop, mobile phone, organiser business cards and pens; dimensions: height 37 cm, width 45 cm, depth 12 cm

Clothes bag

leather clothes bag, folded twice with all round zip, front pocket, leather handle and detachable shoulder strap, Nardia lining with net compartments, 2 zipped compartments, 2 fastening straps; holder for 2 regular clothes hangers; dimensions: height 40 cm, width 57 cm, depth 9 cm

Toiletry bag

v-shaped leather bag with double zipper opening, centre partition with zipped compartment and side pockets with elastic cord. Dimensions: height 9 to 14 cm, width 15 cm, depth 33 cm

Available combinations:

Luggage set for luggage compartment

1 suitcase, 1 briefcase, 1 clothes bag, 2 toiletry bags

Luggage set for the interior

2 suitcases (R8 Coupé)

All seat leather colours and Audi exclusive colours can be individually made with the desired contrasting seams upon request.



R8 Coupé 5.2 FSI quattro in Sepang Blue, pearl effect, with sideblades in Carbon Sigma and forged aluminium wheels in 10-spoke Y design, polished, two-tone. Upholstery and trim: full-leather trim in black Fine Nappa leather, with seams in pale grey, inlays in Carbon Sigma





R8 Coupé 4.2 FSI quattro in Daytona Grey, pearl effect with sideblades in Oxygen Silver and forged aluminium wheels in 5-double-spoke design, high-gloss polished, single-colour. Upholstery and trim: full-leather trim in Fine Nappa leather in mustang brown, headlining in Alcantara black, inlays in matt-silk finish deep black, Bang & Olufsen Sound System



R8 Spyder 5.2 FSI quattro in Brilliant Red with black hood and forged aluminium wheels in 5-double-spoke design, high-gloss polished, single-colour. Upholstery and trim: Fine Nappa full leather trim in black with lunar grey seams, carbon sigma inlays, R8 leather-covered multifunction sports steering wheel in 3-spoke design





R8 Spyder 4.2 FSI quattro in Teak Brown, metallic, with brown hood and forged aluminium wheels in 10-spoke Y design, polished, two-tone. Upholstery and trim: full-leather trim in luxor beige Fine Nappa leather, with seams in luxor beige, inlays in carbon sigma Audi exclusive upholstery and trim: centre console and radio panel in Fine Nappa black with seams in luxor beige, black floor mats with luxor beige piping



Paints R8 Coupé



Ibis White
sideblades in Ice Silver, metallic



Suzuka Grey, metallic
sideblades in Ice Silver, metallic



Sepang Blue, pearl effect
sideblades in Mugello Blue, pearl effect
(R8 Coupé 5.2 FSI quattro)

sideblades R8 Coupé



sideblades in Oxygen Silver
Individual choice of paint colour



Brilliant Red
sideblades in Brilliant Red



Daytona Grey, pearl effect
sideblades in Quartz Grey, metallic



Audi exclusive individual paints
From quattro GmbH



sideblades in Carbon Sigma
Individual choice of paint colour



Jet Blue, metallic
sideblades in Ice Silver, metallic



Lava Grey, pearl effect
sideblades in Quartz Grey, metallic



sideblades in the Audi exclusive colour of your choice
Individual choice of paint colour.
From quattro GmbH



Ice Silver, metallic
sideblades in Apollo Silver, metallic



Phantom Black, pearl effect
sideblades in Lava Grey, pearl effect

sideblades
colour coordinated to the vehicle colour
(R8 Coupé 5.2 FSI quattro features flared sideblades)

Paints R8 Spyder

Hood colours R8 Spyder

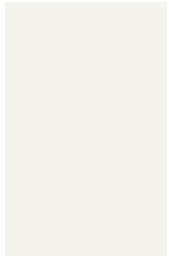

Ibis White

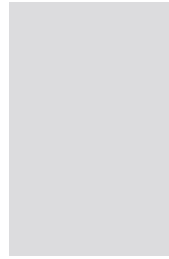

Suzuka Grey, metallic



Lava Grey, pearl effect



Hood, Black



Brilliant Red



Aurum Beige, metallic



Phantom Black, pearl effect



Hood, Red



Jet Blue, metallic



Teak Brown, metallic



Sepang Blue, pearl effect
(R8 Spyder 5.2 FSI quattro)



Hood, Brown



Ice Silver, metallic



Daytona Grey, pearl effect



Audi exclusive individual paints
From quattro GmbH



Sports seats

with shaped side bolsters for better lateral support, manual fore/aft, head restraint and backrest angle adjustment, adjustable seat height for driver and passenger, seat backrest release (R8 Coupé)



Audi exclusive bucket seats

more contoured seat style for increased lateral support, with integral head restraints, manual seat height, fore/aft and backrest angle adjustment, seat backrest release (R8 Coupé), electric 4-way lumbar support and width adjustment of seat cushion and backrest, including seat heaters, without side airbag; seat cover in Fine Nappa leather with embossed R8 logo in seat backrests. From quattro GmbH

Seat covers R8 Coupé



Alcantara/Leather, pale grey

Seat covers R8 Coupé/R8 Spyder



Alcantara/Leather, black



Audi exclusive leather upholstery and trim
From quattro GmbH

Seat covers R8 Spyder



Alcantara/Leather, titanium grey



Fine Nappa leather, pale grey*



Fine Nappa leather, black



Fine Nappa leather, titanium grey*



Fine Nappa leather, mustang brown*



Fine Nappa leather, red*

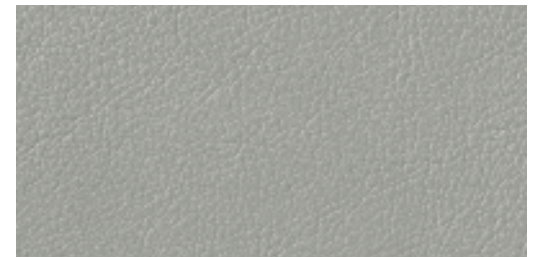

Fine Nappa leather, lunar silver*



Audi exclusive black natural leather for bucket seats
From quattro GmbH



Fine Nappa leather, luxor beige*



Fine Nappa leather, nougat brown*

* Door trims and door handle on front-passenger side in seat colour.

Full-leather trim and upholstery R8 Coupé



Fine Nappa leather seats black and black leather attachments. Seams for seats and attachments in black, optionally in pale grey or mustang brown

Full-leather trim and upholstery R8 Coupé/R8 Spyder



Fine Nappa leather seats black and black leather attachments. Seams for seats and attachments in black, optionally in red or luxor beige

Full-leather trim and upholstery R8 Spyder



Fine Nappa leather seats black and black leather attachments. Seams for seats and attachments in black, optionally in titanium grey, lunar silver or nougat brown



Fine Nappa leather seats pale grey* and black leather attachments. Seams for attachments in black or optionally in pale grey



Fine Nappa leather seats red* and black leather attachments. Seams for attachments in black or optionally in red



Fine Nappa leather seats titanium grey* and black leather attachments. Seams for attachments in black or optionally in titanium grey



Fine Nappa leather seats mustang brown* and black leather attachments. Seams for attachments in black or optionally in mustang brown



Fine Nappa leather seats luxor beige* and black leather attachments. Seams for attachments in black or optionally in luxor beige

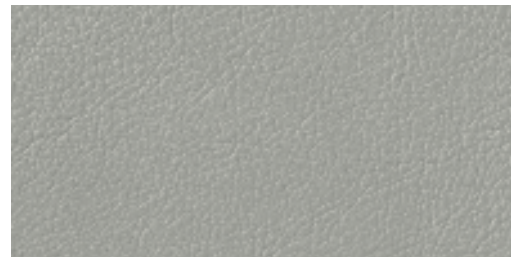

Fine Nappa leather seats lunar silver* and black leather attachments. Seams for attachments in black or optionally in lunar silver



Audi exclusive full-leather trim and upholstery
From quattro GmbH



Fine Nappa leather seats nougat brown* and black leather attachments. Seams for attachments in black or optionally in nougat brown

Seat covers, leather trim and upholstery R8 Coupé/R8 Spyder

Heat protection

(in direct sunlight) for the head restraints, seat side bolsters and seat centre sections; for Alcantara/Leather combination (without seat centre sections) and leather upholstery and trim. The special colour pigmentation of the leather prevents excessive build-up of heat. The infrared radiation in sunlight is reflected. The heat protection can reduce surface temperature up to 20°C. (R8 Spyder)

Alcantara/Leather combination

head restraints and side bolsters in leather (R8 Spyder models including heat protection), seat centre sections in Alcantara

Fine Nappa leather upholstery and trim

seat covers including head restraints (R8 Spyder models including heat protection), passenger-side door trim and door handle in Fine Nappa leather

Fine Nappa full leather trim

the same as Fine Nappa leather upholstery and trim. The following attachments are additionally in black leather: dashboard, door rails, rear side wall trim, door storage compartments, monoposto, instrument panel cover, cover of rear storage compartment, kneepad, function Fine Nappa full leather trim also optionally available with coloured seams

Coloured seams for Fine Nappa full leather trim

Coloured seams for the following items of equipment: Seat covers, monoposto, instrument panel cover, door trim, passenger-side interior door handle, kneepad and cover of rear storage compartment

Audi exclusive R8 package

seat covers in black Fine Nappa leather, seat centre sections with a textured structure optionally available in Signal Orange, Crimson Red or Silver (R8 Spyder models including heat protection), coloured seams on seat side bolsters, instrument panel cover and steering wheel rim to match seat centre sections. From quattro GmbH

Audi exclusive monoposto design package in Fine Nappa leather

the following items are trimmed in leather: monoposto, instrument panel cover, kneepad, driver side handle trim. From quattro GmbH

Audi exclusive leather upholstery and trim (package 1), Fine Nappa leather

seat covers including head restraints (R8 Spyder models including heat protection), passenger-side door handle and door trim in Fine Nappa leather. From quattro GmbH

Audi exclusive leather upholstery and trim (package 1), Alcantara/Leather combination

seat centre panels in Alcantara, seat side bolsters, headrests (for R8 Spyder models including heat protection), passenger-side door handle and door trim in Fine Nappa leather. From quattro GmbH.

Audi exclusive leather upholstery and trim (package 1) in Alcantara/Leather combination for bucket seats

seat centre panels in Alcantara, seat side bolsters, headrests, passenger-side door trim and door handle inserts in Fine Nappa leather. (R8 Coupé). From quattro GmbH

Audi exclusive black natural leather upholstery and trim (package 1) for bucket seats

seat covers in Audi exclusive black natural leather, inside seat side bolster inserts and seat centre panel inserts in the upper area with decorative seams in diamond design, individual choice of colour for decorative seams.

Audi exclusive black natural leather imparts a luxurious character by its natural appearance. The leather is solely coloured “in the barrel” without subsequently applied leather dye and maintains its natural colour. This leather therefore offers a high breathing ability and provides a unique seating climate. The natural material can have slight colour deviations and in time, a typical patina is formed. (R8 Coupé). From quattro GmbH

Audi exclusive leather upholstery and trim (package 2), Fine Nappa leather

seat covers including head restraints (R8 Spyder models including heat protection), door trim, passenger-side door handle, dashboard, door rails, rear side wall trim, door storage compartments, monoposto, instrument panel cover, cover for rear storage compartment, kneepad, function pad in Fine Nappa leather; top side of dashboard available in the following leather colours: black, chestnut brown, saddle brown, cognac brown, Havana brown, smoke blue, night blue, jet grey, classic red, crimson red and iceland green. From quattro GmbH



Full-leather trim with seats in Fine Nappa leather red and attachments in black leather with red seams

Audi exclusive leather upholstery and trim (package 2), Alcantara/Leather combination

seat centre sections in Alcantara, seat side bolsters including head restraints (with heat protection), door trim, passenger-side door handle, dashboard, door rails, rear side wall trim, door storage compartments, monoposto, instrument panel cover, cover for rear storage compartment, kneepad, function pad in Fine Nappa leather; top side of dashboard available in the following leather colours: black, chestnut brown, saddle brown, cognac brown, Havana brown, smoke blue, night blue, jet grey, classic red, crimson red and iceland green. (R8 Spyder). From quattro GmbH

Audi exclusive leather upholstery and trim (package 2) in Alcantara/Leather combination for bucket seats

seat centre sections in Alcantara, seat side bolsters including head restraints (with heat protection), door trim, passenger-side door handle, dashboard, door rails, rear side wall trim, door storage compartments, monoposto, instrument panel cover, cover for rear storage compartment, kneepad, function pad in Fine Nappa leather; top side of dashboard available in the following leather colours: black, chestnut brown, saddle brown, cognac brown, Havana brown, smoke blue, night blue, jet grey, classic red, crimson red and iceland green. (R8 Spyder). From quattro GmbH

Audi exclusive Fine Nappa leather seat trim

for sports seats (can only be ordered in conjunction with Audi exclusive leather upholstery and trim [package 2]). From quattro GmbH

Headlining/hood headlining

Cloth headlining

in black or pale grey to match the selected interior colour. (R8 Coupé)

Headlining in Alcantara

in black, pale grey or luxor beige to match the selected interior colour. (R8 Coupé)

Audi exclusive headlining in Alcantara

available in different Audi exclusive colours. (R8 Coupé). From quattro GmbH

Audi exclusive headlining and parcel shelf in Alcantara

available in different Audi exclusive colours; individual choice of the decorative seams on the headlining. (R8 Coupé). From quattro GmbH

Audi exclusive headlining and rear panel in leather

available in all Audi exclusive colours; individual choice for the decorative seams on the headlining. (R8 Coupé). From quattro GmbH

Hood headlining

in black (R8 Spyder)

* Door trims and door handle on front-passenger side in seat colour.

Inlays

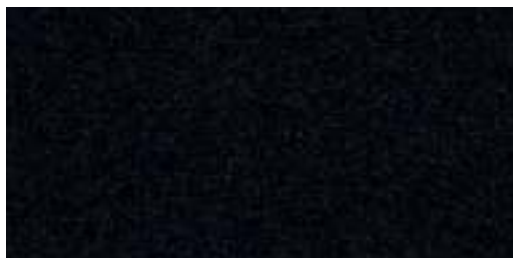

Matt silk finish, deep black

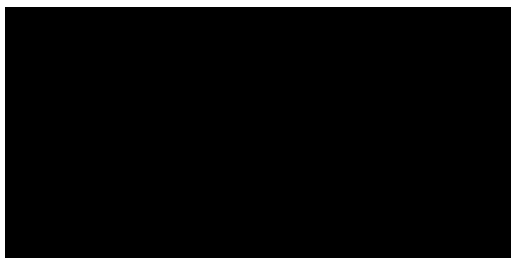

Audi exclusive Piano finish black
From quattro GmbH

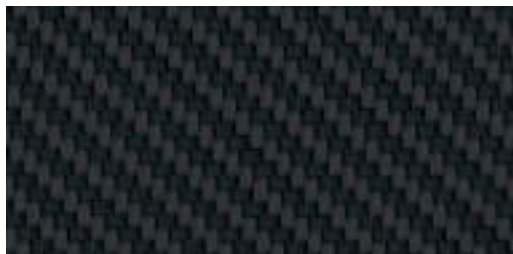

Carbon Sigma



Audi exclusive inlays
optionally in the colour of your choice or Fine Nappa leather.
From quattro GmbH

Inlays

choice of:

matt silk finish, deep black

for radio panel and inlays in the doors and the centre console

in Carbon Sigma

for monoposto, door handles and inlays in doors and centre console

Audi exclusive inlays

From quattro GmbH
choice of:

in Piano finish black

for radio panel and inlays in the doors and the centre console

in Fine Nappa leather

for inlays in the doors and centre console; available in all Audi exclusive colours; passenger-side door handle in leather with decorative seam

in the colour of your choice

for radio panel and inlays in the doors and the centre console; individual choice of colour for paint

Wheels/tyres



Cast aluminium wheels in 6-arm design,
Size 8.5 J x 18 at front, size 10.5 J x 18 at rear, with
235/40 R 18 tyres at front and 285/35 R 18 tyres at rear



Forged aluminium wheels, 5-double spoke design,
Size 8.5 J x 19 at front, size 11 J x 19 at rear, with 235/35
R 19 tyres at front and 295/30 R 19 tyres at rear



Audi exclusive forged aluminium wheels,
10-double-spoke Y design,
high-gloss polished finish, single-colour, size 8.5 J x 19 at
front, size 11 J x 19 at rear, with 235/35 R 19 tyres at
front and 305/30 R 19 tyres at rear. From quattro GmbH



Cast aluminium winter wheels, 6-arm design,
size 8.5 J x 18 at front, size 10.5 J x 18 at rear, with
235/40 R 18 tyres at front and 285/35 R 18 tyres at rear,
permissible top speed 240 km/h, suitable for snow chains



Forged aluminium wheels, 10-spoke Y design,
polished, two-colour, size 8.5 J x 19 at front, size 11 J x
19 at rear, with 235/35 R 19 tyres at front and 295/30 R
19 tyres at rear.



Audi exclusive forged aluminium wheels,
5-double-spoke design,
high-gloss polished finish, single-colour, size 8.5 J x 19 at
front, size 11 J x 19 at rear, with 235/35 R 19 tyres at
front and 305/30 R 19 tyres at rear. From quattro GmbH



Forged aluminium winter wheels,
5-double-spoke design,
size 8.5 J x 19 at front, size 10.5 J x 19 at rear, with
235/35 R 19 tyres at front and 295/30 R 19 tyres at rear,
permissible top speed 240 km/h, suitable for snow chains



Audi exclusive forged aluminium wheels,
5-double-spoke design, in titanium look,
size 8.5 J x 19 at front, size 11 J x 19 at rear, with 235/35
R 19 tyres at front and 305/30 R 19 tyres at rear.
From quattro GmbH

Wheel bolts, anti-theft
can only be loosened using adapter provided

Tyre repair kit
12 volt compressor and tyre sealant, located under
the loading floor cover in the luggage compartment;
top speed 80 km/h

Tyre pressure monitoring system
visual and acoustic warning if the pressure drops in one or
more tyres; display in the driver information system

Vehicle tool kit
in the luggage compartment under the loading floor

Vehicle jack
in the luggage compartment under the loading floor

Lights

Xenon plus including headlight cleaning system

headlights utilising durable gas discharge technology for dipped and high beam ensure intensive illumination of the road and provide good uniformity and range both close up and in the distance. The automatic dynamic headlight range control prevents oncoming traffic from being dazzled; low-energy LED daytime running lights



LED headlights

including headlight cleaning system

dipped beam, high beam, daytime running lights and indicators in full LED technology enable a near-daylight illumination of the road

High-beam assist

within system limits, automatically recognises the headlights of oncoming traffic, the rear lights of other road users and built-up areas. Depending on the traffic situation, the high beam is automatically adjust to dipped-beam and vice versa. The system thereby improves the driver's visibility and safety and ensures a more relaxed drive thanks to the extra comfort and convenience. (Can only be ordered in conjunction with automatically dimming interior mirror with light/rain sensor)



LED rear lights

brake lights, third brake light, indicators and licence plate lights in LED technology. (Black rear light inserts for R8 Coupé/Spyder 5.2 FSI quattro)

Rear fog light

integrated into centre of rear apron

Interior lighting

with delayed switch-off and contact switches on all doors; LED technology utilised for entrance, interior, luggage compartment and glove compartment lighting; active door reflectors

Lighting package

illumination of footwells, inside door handles and engine compartment (R8 Coupé) using LED technology, including automatically dimming interior mirror, with light/rain sensor

Mirrors



Exterior mirrors with integral LED indicators

electrically adjustable and heated, including heated windscreen washer jets; convex, flat or aspherical mirror glass, body-coloured housing choice of:

folding and automatically dimming

(only in conjunction with automatically dimming interior mirror with light/rain sensor)

Audi exclusive exterior mirror housings in carbon

From quattro GmbH

Interior mirror

choice of:

can be dimmed

automatically dimming, with light/rain sensor

to control the automatic lights-on function and the windscreen wipers, includes coming home/leaving home function: delayed switching off/automatic switching on of main headlights, rear and licence plate lights when vehicle is turned off/opened; optionally available with digital compass; this provides a digitised display of the current direction;

Make-up mirror

in driver and front-passenger sun visors

Roof systems (R8 Spyder)

Fully automatic finned hood

made from insulated 3-layer fabric with optimised material thickness and binding techniques for a lower level of noise in the interior; hood opens at up to 50 km/h with one touch operation

Wind deflector

can be stowed with bag in the luggage compartment

Closing systems

Radio-operated remote control

for the central locking, incorporated into the vehicle key, opens and locks doors, windows and luggage compartment at the touch of a button – with variable rolling code

Electronic immobiliser

incorporated in the engine control unit, automatically activated by the vehicle key



Garage door opener (HomeLink)

programmable radio-operated remote control, control button integrated into the interior lighting module; can be used to open and/or close garage doors and exterior gates; allows control of security and lighting systems. For more information, please contact your Audi partner

Anti-theft alarm

including interior monitoring and tow-away protection via angle of inclination sensor, can be deactivated; horn operates independently of vehicle electrical system; monitors engine and luggage compartments, doors and interior

Fitting for Tracking Assistant

fitting for the connecting of a tracking assistant (available from Audi Genuine Accessories), by means of which the stolen vehicle can be located

Glazing

Heat-insulating glass

green tinted, windscreen made of laminated glass with area to view chassis number

Aluminium windscreen frame

(R8 Spyder)

Rear window

heated, with timer switch;
R8 Coupé models: for rear window and partition window, including integral window aerial, black air outlets next to the rear window (R8 Coupé 5.2 FSI quattro models in aluminium look);
R8 Spyder models feature: retractable

Windscreen cleaning system

two speeds, four-speed adjustable intermittent wipe, flick-wipe function, automatic wash/wipe, automatic wiping after the last wash/wipe process

Sun visors

left and right, folding, including covered make-up mirrors

Further exterior equipment



Rear spoiler

can be extended electrically depending on speed; automatic extending at 100 km/h, retracting at 35 km/h; can also be operated manually using the button in the centre console

Bumpers

at front with spoiler edge and large-area black air intakes, at rear with air outlets, fins and striking black diffuser insert; R8 Coupé/Spyder 5.2 FSI quattro models feature front air intakes and spoiler edge and rear air outlets, fins, bumpers between the air outlets and the enlarged diffuser insert painted in high-gloss black

Audi Singleframe

radiator grille painted in high gloss black; R8 Coupé/Spyder 5.2 FSI quattro models feature horizontal and vertical chrome struts

Exhaust system

dual-branch, with round twin tailpipes; R8 Coupé/Spyder 5.2 FSI quattro models feature oval tailpipes



Aluminium tank cover

with embossed R8 logo and electric unlocking

Sill extensions

body-coloured (R8 Coupé/Spyder 5.2 FSI quattro)

R8 logo

on the rear, R8 Coupé/Spyder 5.2 FSI quattro models feature V10 emblem on the side of the front hood

Air outlets in aluminium look

on the hood compartment cover (R8 Spyder)

Audi exclusive Carbon package

front spoiler and rear diffuser in Carbon.
From quattro GmbH

Audi exclusive black styling package

the frame of the radiator grille, radiator grille and licence plate holder, as well as the tailpipe trims of exhaust system in high gloss black;
R8 Coupé 5.2 FSI quattro models feature air outlets of rear window additionally in matt black. R8 Spyder models feature air outlets on the hood compartment cover in high gloss black. From quattro GmbH

Seats/seating comfort

4-way lumbar support

electric, for driver and front-passenger seats, with horizontal and vertical adjustment

Front seats, electrically adjustable

including 4-way lumbar support, electric adjustment of fore/aft position, seat height and seat and backrest angle. (Cannot be ordered in conjunction with Audi exclusive bucket seats)

Seat heating

3 settings, including side bolster heater

Head restraints

height adjustable, integrated in Audi exclusive bucket seats

ISOFIX child seat mounting

for front passenger seat, mounting for child seats in accordance with ISO standard, including deactivation switch for front-passenger airbag. (Not available in conjunction with Audi exclusive bucket seats)

Steering wheels/gear levers/controls



Leather-covered multifunction sports steering wheel in 3-spoke design

flattened at the bottom, with full-size airbag, adjustable for height and reach; for operating all Audi radios, the Bluetooth interface or mobile phone fitting; R tronic models also feature shift paddles behind the steering wheel (R8 Coupé/Spyder 5.2 FSI quattro with shift paddles in aluminium look)

Leather-covered sports steering wheel in 3-spoke design

flattened base, with full size airbag, adjustable for height and reach

Gear/selector lever knob

R8 Coupé/Spyder 5.2 FSI quattro models with red trim ring choice of:

in aluminium

in aluminium with leather inlay



R8 leather-covered multifunction sports steering wheel in 3-spoke design

flattened at the bottom, more heavily contoured steering wheel rim with ergonomic shape, with R8 emblem and full-size air-bag, perforated leather cover, adjustable for height and reach; for operating all Audi radios, the Bluetooth interface or mobile phone fitting; R tronic models also feature aluminium-look shift paddles behind the steering wheel

Audi exclusive leather controls

leather trimmed steering wheel rim, gear/selector lever knob and handbrake grip, available in all Audi exclusive colours. From quattro GmbH

Audi exclusive controls in black suede

leather trimmed steering wheel rim, gear/selector lever knob and handbrake grip in black suede. From quattro GmbH

Air-conditioning

Automatic air conditioning system

specific R8 finish, CFC-free with sunlight-dependent control; electronically regulates air temperature, air flow rate and air distribution; ram air control and recirculation mode, activated charcoal filter

Luggage securing and storage systems

Storage compartment

lockable, illuminated in LED technology, integrated into rear panel. (R8 Spyder)

Glove compartment

on the front-passenger side, lockable, with light and spectacles compartment

Storage package

storage nets on the backs of the seats, storage compartments under seats. R8 Coupé models feature additional luggage net for rear parcel shelf. (Cannot be ordered in conjunction with Audi exclusive bucket seats)

Drinks holders

two, integrated into the centre console

Further interior equipment



Pedals and footrests
in aluminium look

Footwell trim and floor mats

in velour, coordinated with the colour chosen for the interior (black for red, mustang brown, lunar silver and nougat brown seats)

Audi exclusive carpet and parcel shelf/rear panel
including floor mats with leather piping; available in different Audi exclusive colours. From quattro GmbH

Audi exclusive floor mats

floor mats with leather piping; available in different Audi exclusive colours. From quattro GmbH

Audi exclusive floor mats with R8 logo

From quattro GmbH



Door sill trims with aluminium inlays
and R8 emblem on door sills

Audi exclusive door sill trims with illuminated aluminium inlay

the inner edging of the aluminium insert and the R8 logo are illuminated. From quattro GmbH

Audi exclusive door sill trims in Carbon

with aluminium inlays and R8 logo on the door sills. From quattro GmbH

Audi exclusive personalised door sill trims

The aluminium inlay of the door sill trims may be customised with a logo. For more information, please contact your Audi partner. From quattro GmbH



Audi exclusive door sill trims in Carbon with illuminated aluminium inlay

the inner edging of the aluminium insert and the R8 logo are illuminated. From quattro GmbH

Windows

electric, with safety system to limit closing force, one-touch opening/closing function; convenience opening/closing via central locking

Cigarette lighter and ashtray

in the centre console

12 V socket

in the centre console, glove compartment and luggage compartment

Aluminium look in the interior

for radio and automatic air conditioning system controls, rotary light switches and steering wheel spokes

Audi exclusive luggage compartment lining in Alcantara

available in different Audi exclusive colours. From quattro GmbH

Audi exclusive sill trim in Fine Nappa leather

Carpet edge strips and lower sections of the front pillar trim are trimmed with leather; available in all Audi exclusive colours. From quattro GmbH

Audi exclusive vents in Fine Nappa leather

Surrounds and inserts of vents in the instrument panel are trimmed with leather. From quattro GmbH

Audi exclusive centre console and radio panel in Fine Nappa leather

centre console, ashtray cover (R8 Coupé) and radio panel are trimmed with leather. From quattro GmbH

Audi exclusive windscreen frame in Alcantara

interior trim of the windscreen frame including sun visors in Alcantara (R8 Spyder). From quattro GmbH

Audi exclusive windscreen frame in Fine Nappa leather

interior trim of the windscreen frame including sun visors trimmed with leather (R8 Spyder). From quattro GmbH

MMI® and navigation systems**Navigation system plus with MMI® control logic**

includes 2 navigation DVDs, 6.5-inch TFT colour display (800 x 480 pixels) with 3D map display, dynamic route guidance (where available), radio with twin tuner, DVD drive for navigation DVD, audio or MP3 CDs (cannot be played when navigation system is being used), 2 integral MMC/SDHC card readers for MP3 files (up to 32 GB), AUX-IN connection, arrow display in driver information system, display of visual parking information (only if parking system plus is included in the order); includes aerial, 7 loudspeakers and 5-channel amplifier with a total output of 140 watts, connection with Audi music interface possible

Navigation data (2 DVDs)

contains navigation data for the following countries (where digitised): Andorra, Austria, Belgium, Croatia, Czech Republic, Denmark, Estonia, Finland, France, Germany, Greece, Hungary, Ireland, Italy, Latvia, Liechtenstein, Lithuania, Luxembourg, Monaco, the Netherlands, Norway, Poland, Portugal, San Marino, Slovakia, Slovenia, Spain (including the Canary Islands), Sweden, Switzerland, UK, the Vatican City

Driver information system

with high-resolution display in white; with displays for: Auto-Check-Control, digital speed display, radio frequency, 2 adjustable speed warning thresholds, outside temperature, trip computer, LAP timer, doors, engine and luggage compartment monitors

Radio and TV systems**Bang & Olufsen Sound System**

surround sound reproduction via 12 speakers; centre speaker on the instrument panel, 1 midrange speaker and 1 woofer in each door, and 1 tweeter in mirror mount; 1 woofer and tweeter in the rear side panelling on each side; subwoofer; dynamic driving noise compensation; 10-channel amplifier with a total output of 465 watts

concert radio

with single CD player (MP3-compatible), 6.5-inch TFT colour screen, FM (UKW) and AM (MW, LW) reception range, 2 slots for MMC/SD memory card for playing MP3 files, 7 speakers and 5-channel amplifier with a total output of 140 watts; includes AUX-IN connection in the centre console for connecting audio end devices

CD changer

in the parcel shelf (R8 Coupé) or in the storage compartment (R8 Spyder) for 6 CDs, vibration-proof, easily accessible. Each CD can be loaded and changed individually

Audi music interface

for the connection of Apple iPod from generation 4, Apple iPhone (music functionality) as well as USB storage media and MP3 players. Operated via the concert radio, the navigation system plus or a leather-covered multifunction sports steering wheel. Note: can only be used with a special adapter cable (available from Audi Genuine Accessories). Please contact your Audi partner for information on compatible MP3 players

Telephone and communication

Mobile phone fittings (Bluetooth)

including a belt microphone and voice control system; comprises a hands-free facility and voice control for telephone functions as well as a fitting for optional mobile-specific charger; operation via concert radio, navigation system plus or a leather-covered multifunction sports steering wheel; please contact your Audi partner for adapters and information about which mobile phones are compatible

Bluetooth interface

including belt microphone and voice control system; Bluetooth-capable mobile phones can be connected to the vehicle via the interface. Hands-free calls in the vehicle possible via microphone

Belt microphone

3 microphones integrated into each seatbelt. The positioning ensures a more consistent speaking distance of 10–15 cm; speaker can be easily understood

Assistance systems

Parking system front and rear

acoustic indication of how far away the vehicle is from an obstacle at the front and rear; measurement is by ultrasonic sensors concealed discreetly in the bumpers

Parking system plus

acoustic and visual park assist system for the front and rear with display of symbols on the screen to indicate distance from an obstacle; measurement is by ultrasonic sensors concealed discreetly in the bumpers



Parking system plus with reversing camera

acoustic and visual parking aid for front and rear, image of area behind the vehicle shown on the screen, with 2 dynamic display modes showing the calculated path, steer angle dependent, includes help lines and guidelines, reversing camera concealed in rear bumper

Hill-hold assist

after the foot brake is pressed for a longer period of time while the vehicle is stationary, the brake pressure that is built up is maintained for a short while after the brake is released; this automatic braking action makes hill-starts much easier and more comfortable

Cruise control system

maintains the desired speed above around 30 km/h, provided engine power output and engine braking effect permit; operation via separate steering column stalk

Suspension/brakes



Audi magnetic ride*

adaptive damper system with individual selection of suspension settings (Normal/Sport) via button on the centre console; improves ride comfort and handling characteristics by regulating the damping forces according to the driving conditions

Sports suspension

with dynamically tuned spring/damper combination

Braking system

8-piston fixed-calliper brakes at front and 4-piston fixed calliper brakes at rear, adapted brake servo, disc brakes ventilated at front and rear, perforated and with floating bearing

Brake callipers

painted in high-gloss Black, with silver R8 logo

Ceramic brakes

brake discs made from carbon fibre reinforced ceramic, with specially developed cooling channels, ventilated, perforated and with floating bearing; front: 6-piston monoblock aluminium callipers; rear: 4-piston fixed calliper brakes; brake callipers in Anthracite with the "Audi ceramic" logo on the front and rear brake callipers. For high braking performance and fading stability, very long service life. (Can only be ordered in conjunction with 19-inch wheels)

*The image is an illustration, not a real representation.

Technology/safety



Fullsize-Airbags*

for driver and front passenger, two-stage deployment

Side airbags

incorporated into the seat backrests (not in conjunction with Audi exclusive bucket seats)

Audi Space Frame (ASF) body

innovative combination of aluminium and magnesium materials, a high level of stiffness for better handling, greater stability and enhanced safety; R8 Spyder models feature hood compartment cover and rear side panels in carbon fibre reinforced plastic (CRP) to optimise weight while at the same time increasing rigidity

Side impact protection

comprising bend-resistant aluminium impact bars in the doors; activation of side airbags by pressure sensors in the B-pillar; protective side padding in the doors

Rollover protection, active

automatically-triggered protective system behind the head restraints (R8 Spyder)

Integral head restraint system

in the event of a rear-end collision the design of the seat restrains the upper torso and supports the head; this increases safety and reduces the danger of whiplash

Safety steering column

increases the protective potential of the seat belt and airbag; steering wheel can be adjusted mechanically for height and reach

Seat belts

3-point automatic for driver and front-passenger seat, with belt tensioners and belt force limiters

Seat belt reminder

for the driver's seat; an acoustic and optical warning signal reminds you to fasten your seat belt



Instrument cluster

in Micrometallic grey with red needles and R8 logo in rev counter (R8 Coupé/Spyder 5.2 FSI quattro models feature red trim rings, white needles and V10 logo in rev counter, as well as R8 logo in speedometer); with lighting control; coolant and outside temperature display, rev counter with digital clock and date display, speedometer with disproportionate display, odometer/trip odometer, fuel gauge, warning and indicator lights, service interval display, oil temperature, battery display

Audi exclusive dial instrument cluster in white

(R8 Coupé/Spyder 5.2 FSI quattro).
From quattro GmbH

Warning and indicator lamps

for, among others: airbag, ABS, ESP/ASR, handbrake on, EDL electronics, alternator, lights, main beam, indicators, braking system, engine oil pressure, closed tailgate, engine electrics, rear spoiler



Engine compartment cover in Carbon Sigma

(can only be ordered for R8 Coupé in conjunction with lighting package), lettering plate in Carbon Sigma (standard for R8 Coupé 5.2 FSI quattro)

Warning triangle

in the luggage compartment under the loading floor

First-aid kit

in the luggage compartment under the loading floor

Fuel tank

with an increased capacity of 90 l (R8 Coupé)

Technology/safety



Manual transmission

6-speed, fully synchronised, with exposed gear pattern

Anti-lock braking system ABS

with electronic brake force distribution EBD and hydraulic brake assist

Traction control ASR

reduces spinning of the drive wheels by reducing the engine output – thereby improving traction and stability on the road surface

Electronic differential lock EDL

on surfaces with varying levels of grip, this start-off assistant automatically brakes the drive wheels on the surface that is too slippery, thereby ensuring smooth, powerful progress

Electronic Stabilization Programme ESP

with sport mode, disengageable in two stages, includes electronic differential lock EDL and traction control ASR



R tronic

6-speed sequential gearbox with shift-by-wire-technology and sport mode

Power steering

hydraulically supported, maintenance-free rack-and-pinion steering

quattro®

permanent all-wheel drive for increased traction and driving safety, electronic differential lock EDL via braking intervention on all driven wheels

Recuperation

Increasing the generator voltage converts kinetic energy into usable electrical energy when the vehicle is coasting or braking. This energy is used to assist the generator during subsequent acceleration, saving up to 3 % fuel

Audi extended warranty

Audi extended warranty

can be ordered directly and exclusively when you purchase a new vehicle; consistently continues the manufacturer's guarantee and thus offers lasting protection against risk and service cost control even beyond the first 2 years. Choice of 9 service life/total mileage combinations:

Additionally 1 year of Audi extended warranty, maximum mileage of 30,000 km

Additionally 1 year of Audi extended warranty, maximum mileage of 60,000 km

Additionally 1 year of Audi extended warranty, maximum mileage of 90,000 km

Additionally 2 years of Audi extended warranty, maximum mileage of 40,000 km

Additionally 2 years of Audi extended warranty, maximum mileage of 80,000 km

Additionally 2 years of Audi extended warranty, maximum mileage of 120,000 km

Additionally 3 years of Audi extended warranty, maximum mileage of 50,000 km

Additionally 3 years of Audi extended warranty, maximum mileage of 100,000 km

Additionally 3 years of Audi extended warranty, maximum mileage of 150,000 km

Model	R8 Coupé 4.2 FSI quattro		R8 Coupé 5.2 FSI quattro		R8 Spyder 4.2 FSI quattro		R8 Spyder 5.2 FSI quattro		
Engine type	V8 cylinder petrol engine with direct fuel injection		V10 cylinder petrol engine with direct fuel injection		V8 cylinder petrol engine with direct fuel injection		V10 cylinder petrol engine with direct fuel injection		
Displacement in cc (valves per cylinder)	4163 (4)		5204 (4)		4163 (4)		5204 (4)		
Max. output ¹ in kW at rpm	316/7900		386/8000		316/7900		386/8000		
Max. torque in Nm at rpm	430/4500-6000		530/6500		430/4500-6000		530/6500		
Power transmission/wheels									
Type of drive	quattro® permanent all-wheel drive		quattro® permanent all-wheel drive		quattro® permanent all-wheel drive		quattro® permanent all-wheel drive		
Transmission	6-speed manual transmission [sequential 6-speed manual transmission R tronic]		6-speed manual transmission [sequential 6-speed manual transmission R tronic]		6-speed manual transmission [sequential 6-speed manual transmission R tronic]		6-speed manual transmission [sequential 6-speed manual transmission R tronic]		
Wheels	Cast aluminium wheels, size 8.5 J x 18 at front, 10.5 J x 18 at rear		Forged aluminium wheels, size 8.5 J x 19 at front, 11 J x 19 at rear		Cast aluminium wheels, size 8.5 J x 18 at front, 10.5 J x 18 at rear		Forged aluminium wheels, size 8.5 J x 19 at front, 11 J x 19 at rear		
Tyres	235/40 R 18 at front, 285/35 R 18 at rear		235/35 R 19 at front, 295/30 R 19 at rear		235/40 R 18 at front, 285/35 R 18 at rear		235/35 R 19 at front, 295/30 R 19 at rear		
Weights/capacities									
Unladen weight ² in kg	1635	[1640]	1695	[1700]	1735	[1740]	1795	[1800]	
Permitted total vehicle weight in kg	1860	[1865]	1920	[1925]	1960	[1965]	2020	[2025]	
Fuel tank capacity, approx. in l	75		90		80		80		
Performance/consumption³									
Top speed in km/h	302		316		300		313		
Acceleration 0-100 km/h in s	4.6		3.9		4.8		4.1		
Fuel grade	SuperPlus sulphur-free 98 RON ⁴		SuperPlus sulphur-free 98 RON ⁴		SuperPlus sulphur-free 98 RON ⁴		SuperPlus sulphur-free 98 RON ⁴		
Fuel consumption ⁵ in l/100 km	urban	21.3	[20.1]	22.2	[21.1]	21.3	[20.1]	22.2	[21.5]
	extra-urban	10.0	[9.4]	10.6	[9.9]	10.3	[9.6]	10.7	[10.2]
	combined	14.2	[13.3]	14.9	[13.9]	14.4	[13.5]	14.9	[14.2]
CO ₂ emissions ⁵ in g/km	urban	496	[467]	515	[493]	499	[470]	518	[499]
	extra-urban	234	[219]	246	[232]	241	[225]	251	[237]
	combined	332	[310]	346	[326]	337	[315]	349	[332]
Emissions standard	EU5		EU5		EU5		EU5		

Notes

¹ The figure given has been calculated in accordance with the specified measuring procedure (current version of Directive 80/1269/EEC).

² Weight of car, unladen, with driver (68 kg), luggage (7 kg) and fuel tank 90 % full, calculated in accordance with the current version of Directive 92/21/EEC. Optional equipment may increase the car's unladen weight and drag coefficient, whereupon the possible payload limit and the top speed will be reduced accordingly.

³ A vehicle's fuel consumption and CO₂ emissions do not just depend on how efficiently the vehicle uses the fuel, but are also influenced by driving behaviour and other non-technical factors. CO₂ is the greenhouse gas primarily responsible for global warming.

⁴ We recommend using sulphur-free SuperPlus unleaded fuel RON 98 complying with DIN EN 228. If this is not available, use sulphur-free super unleaded RON 95 complying with DIN EN 228; power output will be slightly reduced.

⁵ The figures given were calculated using the specified measuring procedures. The figures do not refer to one individual vehicle and do not form part of any offer, but rather should be used purely for purposes of comparison between the different vehicle models.

Important note

Inspections are due as shown by the service display.

Audi R8 Coupé 4.2 FSI quattro

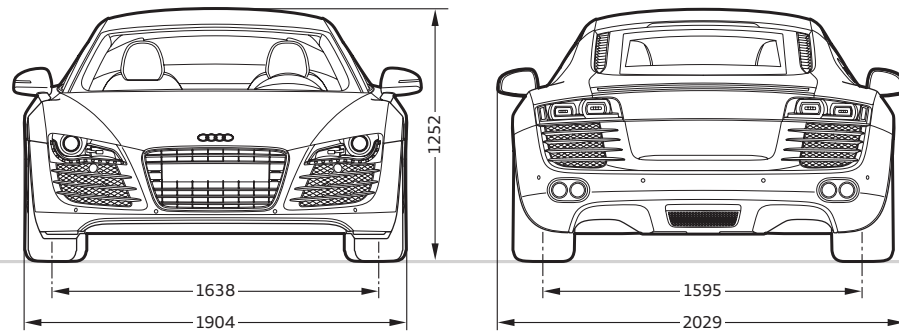
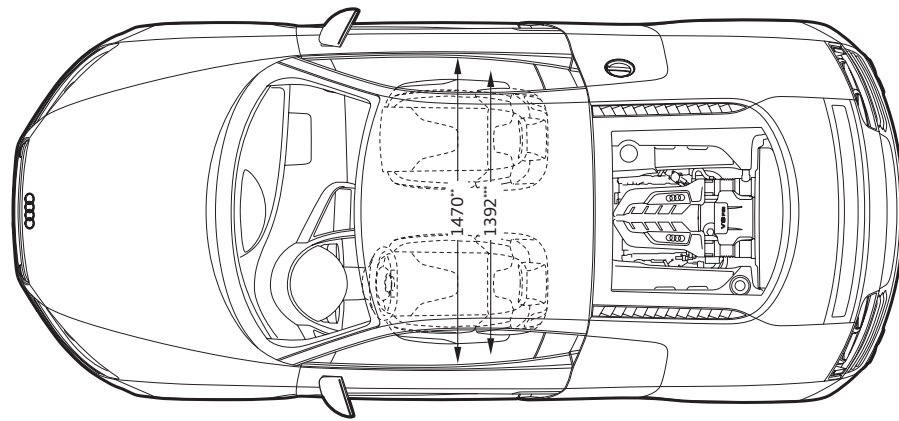
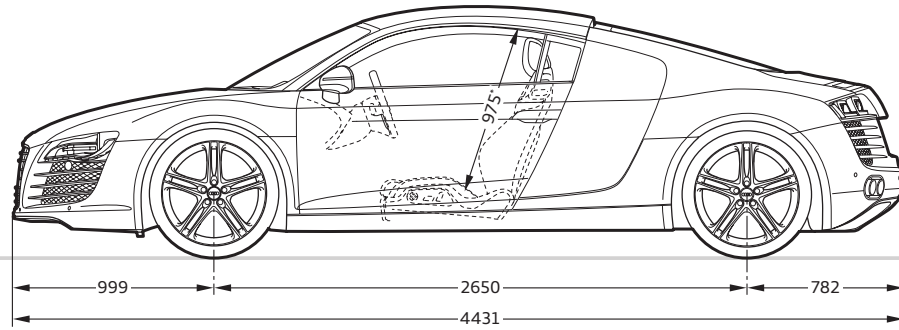

Audi R8 Coupé 5.2 FSI quattro

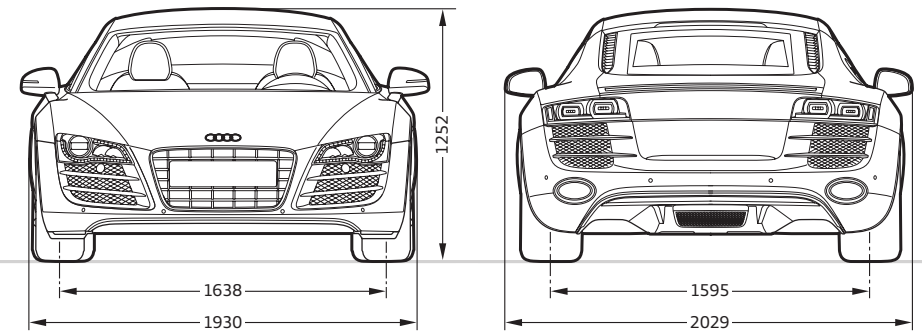
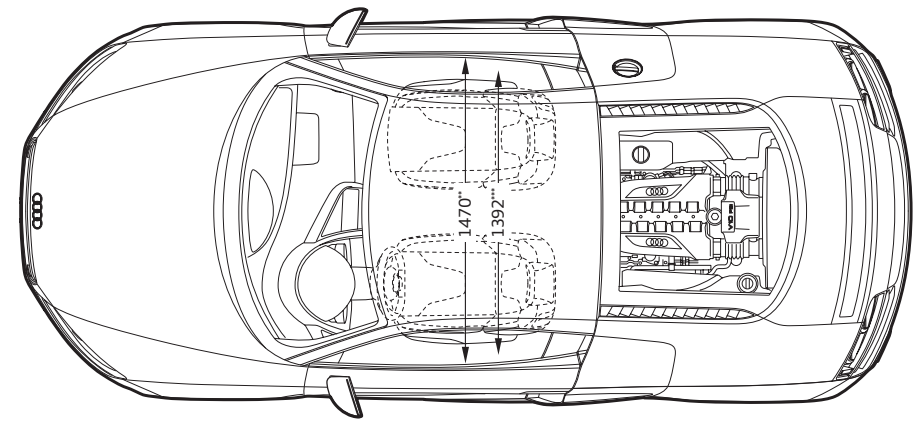
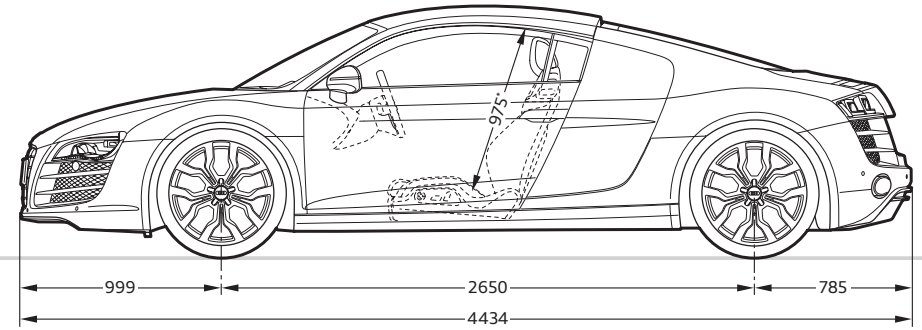

Dimensions in millimetres.

Dimensions were measured with vehicle at unladen weight, ground clearance measured with vehicle carrying its maximum load. Luggage compartment volume in l: 100 (measured by the VDA method using 200 x 100 x 50 mm blocks). Turning circle approx. 11.8 m.

*Maximum headroom. **Elbow room width. ***Shoulder room width.

Dimensions in millimetres.

Dimensions were measured with vehicle at unladen weight, ground clearance measured with vehicle carrying its maximum load. Luggage compartment volume in l: 100 (measured by the VDA method using 200 x 100 x 50 mm blocks). Turning circle approx. 11.8 m.

*Maximum headroom. **Elbow room width. ***Shoulder room width.

Audi R8 Spyder 4.2 FSI quattro

Audi R8 Spyder 5.2 FSI quattro

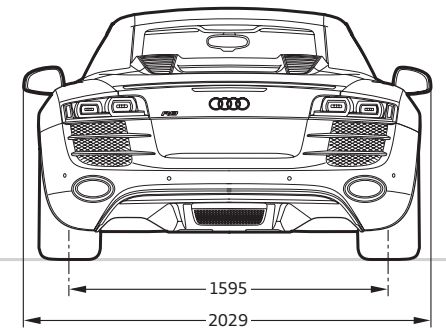
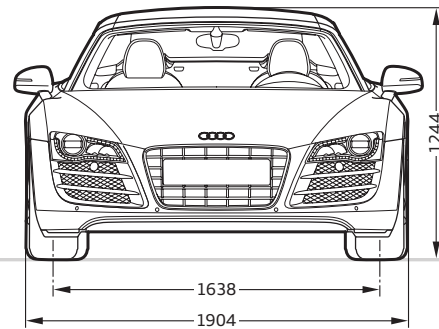
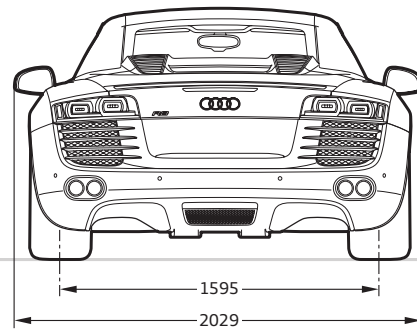
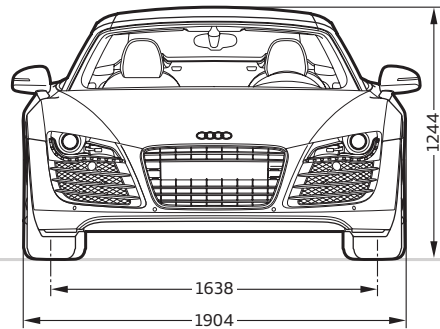
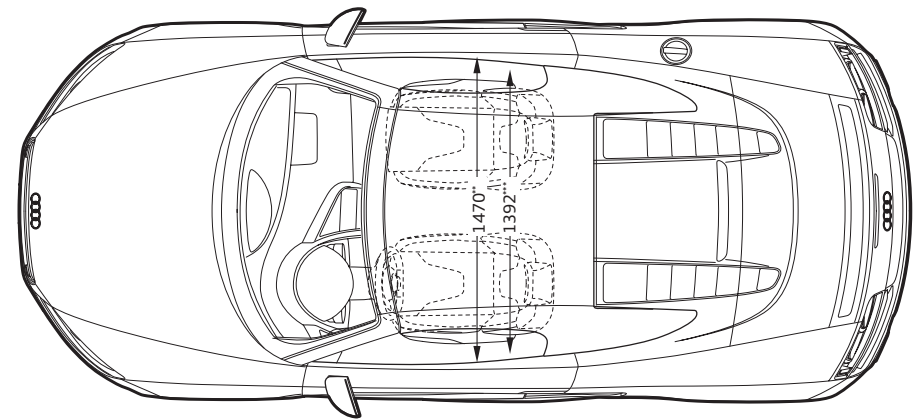
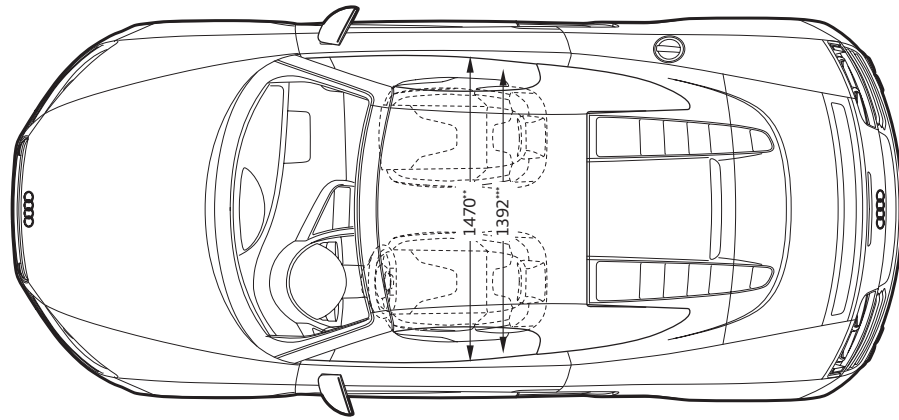
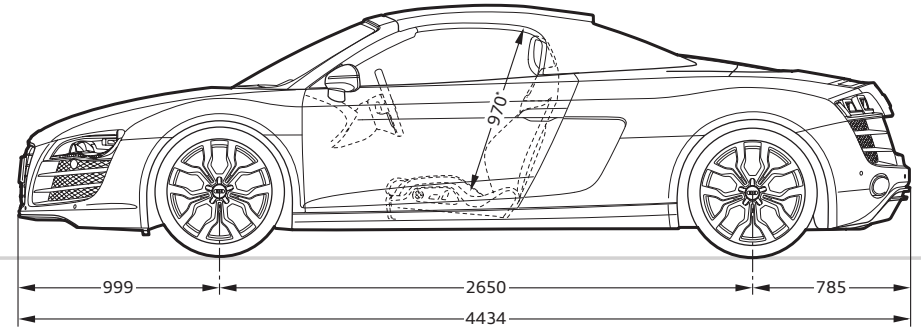
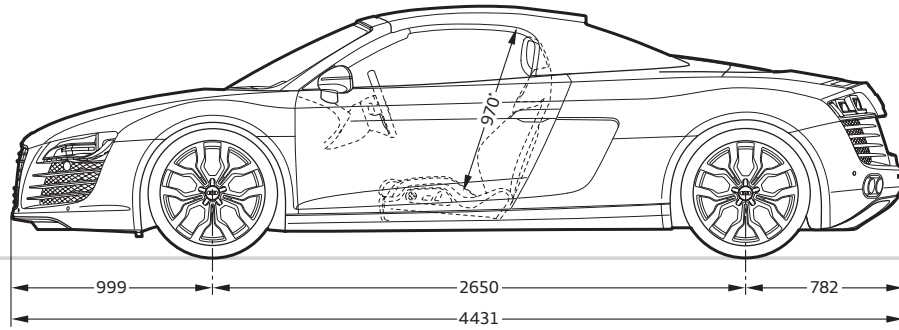

Dimensions in millimetres.

Dimensions were measured with vehicle at unladen weight, ground clearance measured with vehicle carrying its maximum load. Luggage compartment volume in l: 100 (measured by the VDA method using 200 x 100 x 50 mm blocks). Turning circle approx. 11.8 m.

*Maximum headroom. **Elbow room width. ***Shoulder room width.

Dimensions in millimetres.

Dimensions were measured with vehicle at unladen weight, ground clearance measured with vehicle carrying its maximum load. Luggage compartment volume in l: 100 (measured by the VDA method using 200 x 100 x 50 mm blocks). Turning circle approx. 11.8 m.

*Maximum headroom. **Elbow room width. ***Shoulder room width.

	Page	R8 Coupé 4.2 FSI quattro	R8 Coupé 5.2 FSI quattro	R8 Spyder 4.2 FSI quattro	R8 Spyder 5.2 FSI quattro
Paints/sideblades (only for R8 Coupé)	76				
Ibis White (sideblades in Ice Silver, metallic)		<input type="checkbox"/>	<input type="checkbox"/>	<input type="checkbox"/>	<input type="checkbox"/>
Brilliant Red (sideblades in Brilliant Red)		<input type="checkbox"/>	<input type="checkbox"/>	<input type="checkbox"/>	<input type="checkbox"/>
Jet Blue, metallic (sideblades in Ice Silver, metallic)		<input checked="" type="checkbox"/>	<input checked="" type="checkbox"/>	<input checked="" type="checkbox"/>	<input type="checkbox"/>
Ice Silver, metallic (sideblades in Apollo Silver, metallic)		<input checked="" type="checkbox"/>	<input checked="" type="checkbox"/>	<input checked="" type="checkbox"/>	<input type="checkbox"/>
Suzuka Grey, metallic (sideblades in Ice Silver, metallic)		<input checked="" type="checkbox"/>	<input checked="" type="checkbox"/>	<input checked="" type="checkbox"/>	<input type="checkbox"/>
Daytona Grey, pearl effect (sideblades in Quartz Grey, metallic)		<input checked="" type="checkbox"/>	<input checked="" type="checkbox"/>	<input checked="" type="checkbox"/>	<input type="checkbox"/>
Lava Grey, pearl effect (sideblades in Quartz Grey, metallic)		<input checked="" type="checkbox"/>	<input checked="" type="checkbox"/>	<input checked="" type="checkbox"/>	<input type="checkbox"/>
Phantom Black, pearl effect (sideblades in Lava Grey, pearl effect)		<input checked="" type="checkbox"/>	<input checked="" type="checkbox"/>	<input checked="" type="checkbox"/>	<input type="checkbox"/>
Sepang Blue, pearl effect (sideblades in Mugello Blue, pearl effect)		-	<input checked="" type="checkbox"/>	-	<input type="checkbox"/>
Aurum Beige, metallic		-	-	<input checked="" type="checkbox"/>	<input type="checkbox"/>
Teak Brown, metallic		-	-	<input checked="" type="checkbox"/>	<input type="checkbox"/>
Audi exclusive individual paints		<input checked="" type="checkbox"/>	<input checked="" type="checkbox"/>	<input checked="" type="checkbox"/>	<input checked="" type="checkbox"/>
sideblades colour coordinated to the vehicle colour		<input type="checkbox"/>	<input type="checkbox"/>	-	-
sideblades in Oxygen Silver		<input checked="" type="checkbox"/>	<input checked="" type="checkbox"/>	-	-
sideblades in Carbon Sigma		<input checked="" type="checkbox"/>	<input checked="" type="checkbox"/>	-	-
sideblades in the Audi exclusive colour of your choice		<input checked="" type="checkbox"/>	<input checked="" type="checkbox"/>	-	-
Hood colours	77				
Hood, Black		-	-	<input type="checkbox"/>	<input type="checkbox"/>
Hood, Red		-	-	<input type="checkbox"/>	<input type="checkbox"/>
Hood, Brown		-	-	<input type="checkbox"/>	<input type="checkbox"/>
Seats/seat covers	78				
Sports seats		<input type="checkbox"/>	<input type="checkbox"/>	<input type="checkbox"/>	<input type="checkbox"/>
Audi exclusive bucket seats		<input checked="" type="checkbox"/>	<input checked="" type="checkbox"/>	<input checked="" type="checkbox"/>	<input checked="" type="checkbox"/>
Alcantara/Leather, black		<input type="checkbox"/>	<input checked="" type="checkbox"/>	<input type="checkbox"/>	<input checked="" type="checkbox"/>
Alcantara/Leather, pale grey		<input type="checkbox"/>	<input checked="" type="checkbox"/>	-	-
Alcantara/Leather, titanium grey		-	-	<input type="checkbox"/>	<input checked="" type="checkbox"/>
Fine Nappa leather, black		<input checked="" type="checkbox"/>	<input type="checkbox"/>	<input checked="" type="checkbox"/>	<input type="checkbox"/>
Fine Nappa leather, pale grey		<input checked="" type="checkbox"/>	<input type="checkbox"/>	-	-
Fine Nappa leather, titanium grey		-	-	<input checked="" type="checkbox"/>	<input type="checkbox"/>
Fine Nappa leather, lunar silver		-	-	<input checked="" type="checkbox"/>	<input type="checkbox"/>
Fine Nappa leather, red		<input checked="" type="checkbox"/>	<input type="checkbox"/>	<input checked="" type="checkbox"/>	<input type="checkbox"/>

	Page	R8 Coupé 4.2 FSI quattro	R8 Coupé 5.2 FSI quattro	R8 Spyder 4.2 FSI quattro	R8 Spyder 5.2 FSI quattro
Fine Nappa leather, luxor beige		<input checked="" type="checkbox"/>	<input type="checkbox"/>	<input checked="" type="checkbox"/>	<input type="checkbox"/>
Fine Nappa leather, mustang brown		<input checked="" type="checkbox"/>	<input type="checkbox"/>	-	-
Fine Nappa leather, nougat brown		-	-	<input checked="" type="checkbox"/>	<input type="checkbox"/>
Audi exclusive black natural leather for bucket seats		<input checked="" type="checkbox"/>	<input checked="" type="checkbox"/>	-	-
Audi exclusive leather upholstery and trim		<input checked="" type="checkbox"/>	<input checked="" type="checkbox"/>	<input checked="" type="checkbox"/>	<input checked="" type="checkbox"/>
Fine Nappa full leather trim, black		<input checked="" type="checkbox"/>	<input checked="" type="checkbox"/>	<input checked="" type="checkbox"/>	<input checked="" type="checkbox"/>
Fine Nappa full leather trim, pale grey		<input checked="" type="checkbox"/>	<input checked="" type="checkbox"/>	-	-
Fine Nappa full leather trim, titanium grey		-	-	<input checked="" type="checkbox"/>	<input checked="" type="checkbox"/>
Fine Nappa full leather trim, lunar silver		-	-	<input checked="" type="checkbox"/>	<input checked="" type="checkbox"/>
Fine Nappa full leather trim, red		<input checked="" type="checkbox"/>	<input checked="" type="checkbox"/>	<input checked="" type="checkbox"/>	<input checked="" type="checkbox"/>
Fine Nappa full leather trim, luxor beige		<input checked="" type="checkbox"/>	<input checked="" type="checkbox"/>	<input checked="" type="checkbox"/>	<input checked="" type="checkbox"/>
Fine Nappa full leather trim, mustang brown		<input checked="" type="checkbox"/>	<input checked="" type="checkbox"/>	-	-
Fine Nappa full leather trim, nougat brown		-	-	<input checked="" type="checkbox"/>	<input checked="" type="checkbox"/>
Audi exclusive full-leather trim and upholstery		<input checked="" type="checkbox"/>	<input checked="" type="checkbox"/>	<input checked="" type="checkbox"/>	<input checked="" type="checkbox"/>
Heat protection		-	-	<input type="checkbox"/>	<input type="checkbox"/>
Alcantara/Leather combination		<input type="checkbox"/>	<input checked="" type="checkbox"/>	<input type="checkbox"/>	<input checked="" type="checkbox"/>
Fine Nappa leather upholstery and trim		<input checked="" type="checkbox"/>	<input type="checkbox"/>	<input checked="" type="checkbox"/>	<input type="checkbox"/>
Fine Nappa full leather trim		<input checked="" type="checkbox"/>	<input checked="" type="checkbox"/>	<input checked="" type="checkbox"/>	<input checked="" type="checkbox"/>
Coloured seams for Fine Nappa full leather trim		<input checked="" type="checkbox"/>	<input checked="" type="checkbox"/>	<input checked="" type="checkbox"/>	<input checked="" type="checkbox"/>
Audi exclusive R8 package		<input checked="" type="checkbox"/>	<input checked="" type="checkbox"/>	<input checked="" type="checkbox"/>	<input checked="" type="checkbox"/>
Audi exclusive monoposto design package in Fine Nappa leather		<input checked="" type="checkbox"/>	<input checked="" type="checkbox"/>	<input checked="" type="checkbox"/>	<input checked="" type="checkbox"/>
Audi exclusive leather upholstery and trim (package 1), Fine Nappa leather		<input checked="" type="checkbox"/>	<input checked="" type="checkbox"/>	<input checked="" type="checkbox"/>	-
Audi exclusive leather upholstery and trim (package 1), Alcantara/Leather combination		<input checked="" type="checkbox"/>	<input checked="" type="checkbox"/>	<input checked="" type="checkbox"/>	<input checked="" type="checkbox"/>
Audi exclusive leather upholstery and trim (package 1) in Alcantara/Leather combination for bucket seats		<input checked="" type="checkbox"/>	<input checked="" type="checkbox"/>	-	-
Audi exclusive black natural leather upholstery and trim (package 1) for bucket seats für Schalensitze		<input checked="" type="checkbox"/>	<input checked="" type="checkbox"/>	-	-
Audi exclusive leather upholstery and trim (package 2), Fine Nappa leather		<input checked="" type="checkbox"/>	<input checked="" type="checkbox"/>	<input checked="" type="checkbox"/>	<input checked="" type="checkbox"/>
Audi exclusive leather upholstery and trim (package 2), Alcantara/Leather combination		-	-	<input checked="" type="checkbox"/>	<input checked="" type="checkbox"/>
Audi exclusive leather upholstery and trim (package 2) in Alcantara/Leather combination for bucket seats		-	-	<input checked="" type="checkbox"/>	<input checked="" type="checkbox"/>
Audi exclusive Fine Nappa leather seat trim		<input checked="" type="checkbox"/>	<input checked="" type="checkbox"/>	<input checked="" type="checkbox"/>	<input checked="" type="checkbox"/>

Standard equipment Optional equipment - not available

Country-specific deviations are possible. Please find out from your local Audi partner which equipment is standard and what optional equipment is available in your country.

	Page	R8 Coupé 4.2 FSI quattro	R8 Coupé 5.2 FSI quattro	R8 Spyder 4.2 FSI quattro	R8 Spyder 5.2 FSI quattro
Headlining/hood headlining	81				
Cloth headlining		<input type="checkbox"/>	<input type="checkbox"/>	-	-
Headlining in Alcantara		<input checked="" type="checkbox"/>	<input checked="" type="checkbox"/>	-	-
Audi exclusive headlining in Alcantara		<input checked="" type="checkbox"/>	<input checked="" type="checkbox"/>	-	-
Audi exclusive headlining and parcel shelf in Alcantara		<input checked="" type="checkbox"/>	<input checked="" type="checkbox"/>	-	-
Audi exclusive headlining and rear panel in leather		<input checked="" type="checkbox"/>	<input checked="" type="checkbox"/>	-	-
Headlining in black		-	-	<input type="checkbox"/>	<input type="checkbox"/>
Inlays	82				
Matt silk finish, deep black		<input type="checkbox"/>	<input type="checkbox"/>	<input type="checkbox"/>	<input type="checkbox"/>
Carbon Sigma		<input checked="" type="checkbox"/>	<input checked="" type="checkbox"/>	<input checked="" type="checkbox"/>	<input checked="" type="checkbox"/>
Audi exclusive Piano finish black		<input checked="" type="checkbox"/>	<input checked="" type="checkbox"/>	<input checked="" type="checkbox"/>	<input checked="" type="checkbox"/>
Audi exclusive Fine Nappa leather		<input checked="" type="checkbox"/>	<input checked="" type="checkbox"/>	<input checked="" type="checkbox"/>	<input checked="" type="checkbox"/>
Audi exclusive colour of your choice		<input checked="" type="checkbox"/>	<input checked="" type="checkbox"/>	<input checked="" type="checkbox"/>	<input checked="" type="checkbox"/>
Wheels/tyres	83				
Cast aluminium wheels, 6-arm design		<input type="checkbox"/>	-	<input type="checkbox"/>	-
Forged aluminium wheels, 10-spoke Y design		<input checked="" type="checkbox"/>	<input type="checkbox"/>	<input checked="" type="checkbox"/>	<input type="checkbox"/>
Forged aluminium wheels, 5-double-spoke design		<input checked="" type="checkbox"/>	<input checked="" type="checkbox"/>	<input checked="" type="checkbox"/>	<input checked="" type="checkbox"/>
Audi exclusive forged aluminium wheels, 5-double-spoke design, high-gloss polished finish, single tone		<input checked="" type="checkbox"/>	<input checked="" type="checkbox"/>	<input checked="" type="checkbox"/>	<input checked="" type="checkbox"/>
Audi exclusive forged aluminium wheels, 5-double-spoke design, in titanium look		<input checked="" type="checkbox"/>	<input checked="" type="checkbox"/>	<input checked="" type="checkbox"/>	<input checked="" type="checkbox"/>
Audi exclusive forged aluminium wheels, 10-double-spoke Y design, high-gloss polished finish, single tone		<input checked="" type="checkbox"/>	<input checked="" type="checkbox"/>	<input checked="" type="checkbox"/>	<input checked="" type="checkbox"/>
Cast aluminium winter wheels, 6-arm design		<input checked="" type="checkbox"/>	<input checked="" type="checkbox"/>	<input checked="" type="checkbox"/>	<input checked="" type="checkbox"/>
Forged aluminium winter wheels, 5-double-spoke design		<input checked="" type="checkbox"/>	<input checked="" type="checkbox"/>	<input checked="" type="checkbox"/>	<input checked="" type="checkbox"/>
Wheel bolts, anti-theft		<input type="checkbox"/>	<input type="checkbox"/>	<input type="checkbox"/>	<input type="checkbox"/>
Tyre repair kit		<input type="checkbox"/>	<input type="checkbox"/>	<input type="checkbox"/>	<input type="checkbox"/>
Tyre pressure monitoring system		<input checked="" type="checkbox"/>	<input checked="" type="checkbox"/>	<input checked="" type="checkbox"/>	<input checked="" type="checkbox"/>
Vehicle tool kit		<input type="checkbox"/>	<input type="checkbox"/>	<input type="checkbox"/>	<input type="checkbox"/>
Vehicle jack		<input checked="" type="checkbox"/>	<input checked="" type="checkbox"/>	<input checked="" type="checkbox"/>	<input checked="" type="checkbox"/>

	Page	R8 Coupé 4.2 FSI quattro	R8 Coupé 5.2 FSI quattro	R8 Spyder 4.2 FSI quattro	R8 Spyder 5.2 FSI quattro
Lights	84				
Xenon plus including headlight cleaning system		<input type="checkbox"/>	<input checked="" type="checkbox"/>	<input type="checkbox"/>	<input checked="" type="checkbox"/>
LED headlights including headlight cleaning system		<input checked="" type="checkbox"/>	<input type="checkbox"/>	<input checked="" type="checkbox"/>	<input type="checkbox"/>
High-beam assist		<input checked="" type="checkbox"/>	<input checked="" type="checkbox"/>	<input checked="" type="checkbox"/>	<input checked="" type="checkbox"/>
LED rear lights		<input type="checkbox"/>	<input type="checkbox"/>	<input type="checkbox"/>	<input type="checkbox"/>
Rear fog light		<input type="checkbox"/>	<input type="checkbox"/>	<input type="checkbox"/>	<input type="checkbox"/>
Interior lighting		<input type="checkbox"/>	<input type="checkbox"/>	<input type="checkbox"/>	<input type="checkbox"/>
Lighting package		<input checked="" type="checkbox"/>	<input checked="" type="checkbox"/>	<input checked="" type="checkbox"/>	<input checked="" type="checkbox"/>
Mirrors	84				
Exterior mirrors with integral LED indicators		<input type="checkbox"/>	<input type="checkbox"/>	<input type="checkbox"/>	<input type="checkbox"/>
Exterior mirrors with integral LED indicators, folding and automatically dimming		<input checked="" type="checkbox"/>	<input checked="" type="checkbox"/>	<input checked="" type="checkbox"/>	<input checked="" type="checkbox"/>
Audi exclusive exterior mirror housings in carbon		<input checked="" type="checkbox"/>	<input checked="" type="checkbox"/>	<input checked="" type="checkbox"/>	<input checked="" type="checkbox"/>
Interior mirror, dimming		<input type="checkbox"/>	<input type="checkbox"/>	<input type="checkbox"/>	<input type="checkbox"/>
Interior mirror, automatically dimming, with light/rain sensor		<input checked="" type="checkbox"/>	<input checked="" type="checkbox"/>	<input checked="" type="checkbox"/>	<input checked="" type="checkbox"/>
Interior mirror, automatically dimming, with light/rain sensor and digital compass display		<input checked="" type="checkbox"/>	<input checked="" type="checkbox"/>	<input checked="" type="checkbox"/>	<input checked="" type="checkbox"/>
Make-up mirror		<input type="checkbox"/>	<input type="checkbox"/>	<input type="checkbox"/>	<input type="checkbox"/>
Roof systems	84				
Fully automatic finned hood		-	-	<input type="checkbox"/>	<input type="checkbox"/>
Wind deflector		-	-	<input type="checkbox"/>	<input type="checkbox"/>
Closing systems	84				
Radio-operated remote control		<input type="checkbox"/>	<input type="checkbox"/>	<input type="checkbox"/>	<input type="checkbox"/>
Electronic immobiliser		<input type="checkbox"/>	<input type="checkbox"/>	<input type="checkbox"/>	<input type="checkbox"/>
Garage door opener (HomeLink)		<input checked="" type="checkbox"/>	<input checked="" type="checkbox"/>	<input checked="" type="checkbox"/>	<input checked="" type="checkbox"/>
Anti-theft alarm		<input type="checkbox"/>	<input type="checkbox"/>	<input type="checkbox"/>	<input type="checkbox"/>
Fitting for Tracking Assistant		<input checked="" type="checkbox"/>	<input checked="" type="checkbox"/>	<input checked="" type="checkbox"/>	<input checked="" type="checkbox"/>
Glazing	85				
Heat-insulating glass		<input type="checkbox"/>	<input type="checkbox"/>	<input type="checkbox"/>	<input type="checkbox"/>
Aluminium windscreen frame		-	-	<input type="checkbox"/>	<input type="checkbox"/>
Rear window		<input type="checkbox"/>	<input type="checkbox"/>	<input type="checkbox"/>	<input type="checkbox"/>
Windscreen cleaning system		<input type="checkbox"/>	<input type="checkbox"/>	<input type="checkbox"/>	<input type="checkbox"/>
Sun visors		<input type="checkbox"/>	<input type="checkbox"/>	<input type="checkbox"/>	<input type="checkbox"/>

	Page	R8 Coupé 4.2 FSI quattro	R8 Coupé 5.2 FSI quattro	R8 Spyder 4.2 FSI quattro	R8 Spyder 5.2 FSI quattro
Further exterior equipment	85				
Rear spoiler		<input type="checkbox"/>	<input type="checkbox"/>	<input type="checkbox"/>	<input type="checkbox"/>
Bumpers		<input type="checkbox"/>	<input type="checkbox"/>	<input type="checkbox"/>	<input type="checkbox"/>
Audi Singleframe		<input type="checkbox"/>	<input type="checkbox"/>	<input type="checkbox"/>	<input type="checkbox"/>
Exhaust system		<input type="checkbox"/>	<input type="checkbox"/>	<input type="checkbox"/>	<input type="checkbox"/>
Aluminium tank cover		<input type="checkbox"/>	<input type="checkbox"/>	<input type="checkbox"/>	<input type="checkbox"/>
Sill extensions		–	<input type="checkbox"/>	–	<input type="checkbox"/>
R8 logo		<input type="checkbox"/>	<input type="checkbox"/>	<input type="checkbox"/>	<input type="checkbox"/>
Air outlets in aluminium look		–	–	<input type="checkbox"/>	<input type="checkbox"/>
Audi exclusive Carbon package		<input checked="" type="checkbox"/>	<input checked="" type="checkbox"/>	<input checked="" type="checkbox"/>	<input checked="" type="checkbox"/>
Audi exclusive black styling package		<input checked="" type="checkbox"/>	<input checked="" type="checkbox"/>	<input checked="" type="checkbox"/>	<input checked="" type="checkbox"/>
Seats/seating comfort	86				
4-way lumbar support		<input checked="" type="checkbox"/>	<input checked="" type="checkbox"/>	<input checked="" type="checkbox"/>	<input checked="" type="checkbox"/>
Front seats, electrically adjustable		<input checked="" type="checkbox"/>	<input checked="" type="checkbox"/>	<input checked="" type="checkbox"/>	<input checked="" type="checkbox"/>
Seat heating		<input checked="" type="checkbox"/>	<input type="checkbox"/>	<input checked="" type="checkbox"/>	<input type="checkbox"/>
Head restraints		<input type="checkbox"/>	<input type="checkbox"/>	<input type="checkbox"/>	<input type="checkbox"/>
ISOFIX child seat mounting		<input checked="" type="checkbox"/>	<input checked="" type="checkbox"/>	<input checked="" type="checkbox"/>	<input checked="" type="checkbox"/>
Steering wheels/gear levers/controls	86				
Leather-covered sports steering wheel in 3-spoke design		<input type="checkbox"/> ¹	<input type="checkbox"/> ¹	<input type="checkbox"/> ¹	<input type="checkbox"/> ¹
Leather-covered multifunction sports steering wheel in 3-spoke design		<input type="checkbox"/> ²	<input type="checkbox"/> ²	<input type="checkbox"/> ²	<input type="checkbox"/> ²
R8 leather-covered multifunction sports steering wheel in 3-spoke design		<input checked="" type="checkbox"/>	<input checked="" type="checkbox"/>	<input checked="" type="checkbox"/>	<input checked="" type="checkbox"/>
Gear/selector lever knob in aluminium		<input type="checkbox"/>	<input type="checkbox"/>	<input type="checkbox"/>	<input type="checkbox"/>
Gear/selector lever knob in aluminium with leather inlay		<input checked="" type="checkbox"/>	<input checked="" type="checkbox"/>	<input checked="" type="checkbox"/>	<input checked="" type="checkbox"/>
Audi exclusive leather controls		<input checked="" type="checkbox"/>	<input checked="" type="checkbox"/>	<input checked="" type="checkbox"/>	<input checked="" type="checkbox"/>
Audi exclusive controls in black suede		<input checked="" type="checkbox"/>	<input checked="" type="checkbox"/>	<input checked="" type="checkbox"/>	<input checked="" type="checkbox"/>
Air-conditioning	86				
Automatic air conditioning system		<input type="checkbox"/>	<input type="checkbox"/>	<input type="checkbox"/>	<input type="checkbox"/>
Luggage securing and storage systems	86				
Storage compartment		–	–	<input type="checkbox"/>	<input type="checkbox"/>
Glove compartment		<input type="checkbox"/>	<input type="checkbox"/>	<input type="checkbox"/>	<input type="checkbox"/>
Storage package		<input checked="" type="checkbox"/>	<input checked="" type="checkbox"/>	<input checked="" type="checkbox"/>	<input checked="" type="checkbox"/>
Drinks holders		<input type="checkbox"/>	<input type="checkbox"/>	<input type="checkbox"/>	<input type="checkbox"/>

Standard equipment Optional equipment Standard/optional equipment depends on the model
Country-specific deviations are possible. Please find out from your local Audi partner which equipment is standard and what optional equipment is available in your country.

	Page	R8 Coupé 4.2 FSI quattro	R8 Coupé 5.2 FSI quattro	R8 Spyder 4.2 FSI quattro	R8 Spyder 5.2 FSI quattro
R8 luggage sets	70				
Luggage set for luggage compartment		<input checked="" type="checkbox"/>	<input checked="" type="checkbox"/>	<input checked="" type="checkbox"/>	<input checked="" type="checkbox"/>
Luggage set for the interior		<input checked="" type="checkbox"/>	<input checked="" type="checkbox"/>	–	–
Further interior equipment	87				
Pedals and footrests in aluminium look		<input checked="" type="checkbox"/>	<input type="checkbox"/>	<input checked="" type="checkbox"/>	<input type="checkbox"/>
Footwell trim and floor mats		<input type="checkbox"/>	<input type="checkbox"/>	<input type="checkbox"/>	<input type="checkbox"/>
Audi exclusive carpet and parcel shelf/rear panel		<input checked="" type="checkbox"/>	<input checked="" type="checkbox"/>	<input checked="" type="checkbox"/>	<input checked="" type="checkbox"/>
Audi exclusive floor mats		<input checked="" type="checkbox"/>	<input checked="" type="checkbox"/>	<input checked="" type="checkbox"/>	<input checked="" type="checkbox"/>
Audi exclusive floor mats with R8 logo		<input checked="" type="checkbox"/>	<input checked="" type="checkbox"/>	<input checked="" type="checkbox"/>	<input checked="" type="checkbox"/>
Door sill trims with aluminium inlays		<input type="checkbox"/>	<input type="checkbox"/>	<input type="checkbox"/>	<input type="checkbox"/>
Audi exclusive door sill trims with illuminated aluminium inlay		<input checked="" type="checkbox"/>	<input checked="" type="checkbox"/>	<input checked="" type="checkbox"/>	<input checked="" type="checkbox"/>
Audi exclusive door sill trims in Carbon		<input checked="" type="checkbox"/>	<input checked="" type="checkbox"/>	<input checked="" type="checkbox"/>	<input checked="" type="checkbox"/>
Audi exclusive door sill trims in Carbon with illuminated aluminium inlay		<input checked="" type="checkbox"/>	<input checked="" type="checkbox"/>	<input checked="" type="checkbox"/>	<input checked="" type="checkbox"/>
Audi exclusive personalised door sill trims		<input checked="" type="checkbox"/>	<input checked="" type="checkbox"/>	<input checked="" type="checkbox"/>	<input checked="" type="checkbox"/>
Windows		<input type="checkbox"/>	<input type="checkbox"/>	<input type="checkbox"/>	<input type="checkbox"/>
Cigarette lighter and ashtray		<input type="checkbox"/>	<input type="checkbox"/>	<input type="checkbox"/>	<input type="checkbox"/>
12 V socket		<input type="checkbox"/>	<input type="checkbox"/>	<input type="checkbox"/>	<input type="checkbox"/>
Aluminium look in the interior		<input type="checkbox"/>	<input type="checkbox"/>	<input type="checkbox"/>	<input type="checkbox"/>
Audi exclusive luggage compartment lining in Alcantara		<input checked="" type="checkbox"/>	<input checked="" type="checkbox"/>	<input checked="" type="checkbox"/>	<input checked="" type="checkbox"/>
Audi exclusive sill trim in Fine Nappa leather		<input checked="" type="checkbox"/>	<input checked="" type="checkbox"/>	<input checked="" type="checkbox"/>	<input checked="" type="checkbox"/>
Audi exclusive vents in Fine Nappa leather		<input checked="" type="checkbox"/>	<input checked="" type="checkbox"/>	<input checked="" type="checkbox"/>	<input checked="" type="checkbox"/>
Audi exclusive centre console and radio panel in Fine Nappa leather		<input checked="" type="checkbox"/>	<input checked="" type="checkbox"/>	<input checked="" type="checkbox"/>	<input checked="" type="checkbox"/>
Audi exclusive windscreen frame in Alcantara		–	–	<input checked="" type="checkbox"/>	<input checked="" type="checkbox"/>
Audi exclusive windscreen frame in Fine Nappa leather		–	–	<input checked="" type="checkbox"/>	<input checked="" type="checkbox"/>
MMI® and navigation systems	88				
Navigation system plus with MMI® control logic		<input checked="" type="checkbox"/>	<input checked="" type="checkbox"/>	<input checked="" type="checkbox"/>	<input checked="" type="checkbox"/>
Navigation data (2 DVDs)		<input checked="" type="checkbox"/>	<input checked="" type="checkbox"/>	<input checked="" type="checkbox"/>	<input checked="" type="checkbox"/>
Driver information system		<input type="checkbox"/>	<input type="checkbox"/>	<input type="checkbox"/>	<input type="checkbox"/>
Radio and TV systems	88				
concert radio		<input type="checkbox"/>	<input type="checkbox"/>	<input type="checkbox"/>	<input type="checkbox"/>
Bang & Olufsen Sound System		<input checked="" type="checkbox"/>	<input checked="" type="checkbox"/>	<input checked="" type="checkbox"/>	<input checked="" type="checkbox"/>
CD changer		<input checked="" type="checkbox"/>	<input checked="" type="checkbox"/>	<input checked="" type="checkbox"/>	<input checked="" type="checkbox"/>
Audi music interface		<input checked="" type="checkbox"/>	<input checked="" type="checkbox"/>	<input checked="" type="checkbox"/>	<input checked="" type="checkbox"/>

– not available

	Page	R8 Coupé 4.2 FSI quattro	R8 Coupé 5.2 FSI quattro	R8 Spyder 4.2 FSI quattro	R8 Spyder 5.2 FSI quattro
Telephone and communication	89				
Bluetooth interface		■	■	■	■
Mobile phone fittings (Bluetooth)		■	■	■	■
Belt microphone		■	■	■	■
Assistance systems	89				
Parking system front and rear		■	■	■	■
Parking system plus		■	■	■	■
Parking system plus with reversing camera		■	■	■	■
Hill-hold assist		■	□	■	□
Cruise control system		■	■	■	■
Suspension/brakes	89				
Sports suspension		□	□	□	□
Audi magnetic ride		■	■	■	■
Braking system		□	□	□	□
Brake callipers		□	□	□	□
Ceramic brakes		■	■	■	■
Technology/safety	90				
Full-size airbags		□	□	□	□
Side airbags		□	□	□	□
Audi Space Frame (ASF) body		□	□	□	□
Side impact protection		□	□	□	□
Rollover protection, active		-	-	□	□
Integral head restraint system		□	□	□	□
Safety steering column		□	□	□	□
Seat belts		□	□	□	□
Seat belt reminder		□	□	□	□
Instrument cluster		□	□	□	□
Audi exclusive dial instrument cluster in white		-	■	-	■
Warning and indicator lights		□	□	□	□
Engine compartment cover in Carbon Sigma		■	■	■	■
Warning triangle		□	□	□	□
First-aid kit		□	□	□	□

	Page	R8 Coupé 4.2 FSI quattro	R8 Coupé 5.2 FSI quattro	R8 Spyder 4.2 FSI quattro	R8 Spyder 5.2 FSI quattro
Fuel tank with increased capacity of 90 l		■	□	-	-
Manual transmission		□	□	□	□
R tronic		□	□	□	□
Anti-lock braking system ABS		□	□	□	□
Traction control ASR		□	□	□	□
Electronic differential lock EDL		□	□	□	□
Electronic Stabilization Programme ESP		□	□	□	□
Power steering		□	□	□	□
quattro®		□	□	□	□
Recuperation		□	□	□	□
Audi extended warranty	91				
Audi extended warranty		■	■	■	■

Equipment of the R8 Coupé 4.2 FSI quattro which is shown on pages 8-29:
Paint: Ice Silver, metallic with sideblades in Carbon Sigma; wheels: forged aluminium wheels in 5-double spoke design;
seat covers: Fine Nappa full leather trim in black; inlays: Carbon Sigma

Equipment of the R8 Coupé 5.2 FSI quattro which is shown on pages 8-29:
Paint: Brilliant Red with sideblades in Oxygen Silver; wheels: Forged aluminium wheels, 10-spoke Y design, polished,
two-tone; seat covers: full-leather trim in black Fine Nappa leather, with seams in pale grey; inlays: Carbon Sigma

Equipment of the R8 Spyder 4.2 FSI quattro which is shown on pages 52 and 53:
Paint: Teak Brown, metallic , with brown hood; wheels: Forged aluminium wheels, 10-spoke Y design, polished,
two-tone; seat covers: Fine Nappa full leather trim in luxor beige; inlays: Carbon Sigma

Equipment of the R8 Spyder 5.2 FSI quattro which is shown on pages 32-56:
Paint: Suzuka Grey, metallic , with black hood; wheels: Forged aluminium wheels, 10-spoke Y design, polished,
two-tone; seat covers: full-leather trim in red Fine Nappa leather, with seams in red; inlays: Carbon Sigma;
Audi exclusive equipment: centre console and radio panel in Fine Nappa black with seams in red, black floor mats
with red piping

¹ Only for manual transmission. ² Standard equipment for R tronic, optional equipment for manual transmission.

At Audi, you get much more than just an Audi.

Anybody who chooses an Audi chooses a brand that offers its customers more. More individuality. More exclusivity. And more fascination.



www.audi.com

Vorsprung durch Technik, and everything that it entails: the legendary Audi history, dates of unforgettable events and ground-breaking innovations – let your fascination grow with the Audi brand.

> www.audi.com



Audi Konfigurator

Create your own personal Audi using the Audi configurator. All current models, engines, colours and equipment options are available for you to choose from.

> www.audi.com



Audi tv

On Audi tv you can discover new facets of our brand with the four rings: exciting commentaries on our models, technical innovations, fascinating events from the fields of motorsports, tradition, culture and lifestyle. Take a look behind the scenes. The latest news every day. Round the clock.

> www.audi.tv



Audi Bank

Financing. Leasing. Insuring. Whichever new Audi you decide on, every quotation from the Audi Bank is individually tailored to you. Our special offer packages, for example, combine current financing and leasing options with comprehensive insurance protection and thus offer you unlimited mobility.

> www.audi.com



quattro GmbH
85045 Ingolstadt
www.audi.com
Valid from April 2011

Printed in Germany
133/1130.88.18

The models and equipment versions illustrated and described in this brochure and some of the services listed are not available in all countries. Some of the cars illustrated are equipped with optional features for which an extra charge is made. Details concerning the delivery specifications, appearance, performance, dimensions and weights, fuel consumption and running costs of the vehicle were correct to the best of our knowledge at the time of going to press. Deviations from the colours and shapes shown in the illustrations may occur. No liability is accepted for errors and printing errors. The right to introduce modifications is reserved. Not to be reproduced, including in part, without the written approval of AUDI AG.

This brochure is printed on paper made from pulp bleached without the use of chlorine.