



allroad

Audi allroad

Audi
Truth in Engineering



It's Audi because

we're driven by human achievement.

More than just cars, more than just performance. Audi is about the nature of perception, determining how people will respond to and interact with innovative design. It's about applied physics, how things glide through the air and overcome inertia through the application of power, acceleration and exhilaration.¹ It's about artistry, and the way materials elicit a tactile response and provoke an emotional response. It's

chemistry and how it bonds with you. It's poetry written in metal, engineering and design. Audi is the product of learning and application of knowledge. At its best, it is a dynamic example of what humans can create when they are vested in creating something better and bolder. So Audi is not just about cars. But then again, of course, it's also about cars.



It's Audi because

luxury tells the ornate, the garish, the gilded and the over-indulgent...

→ Ornate elements don't help to tell time →

→ Gilt prone to dull →

→ Unnecessary weight means mantle and not wall →



1 Always pay careful attention to the road, and do not drive while distracted. The features and technologies discussed above are optional, may require an additional subscription with separate terms and conditions, and should be used only when it is safe and appropriate. The Wi-Fi® hotspot feature is intended for passenger use only. 2 Features and technologies listed will not be available on all models.

...time's up.

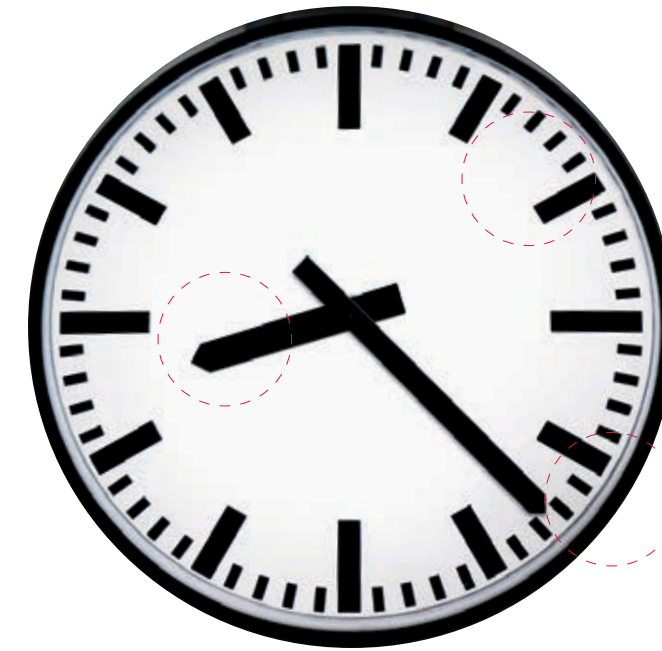

← Precise design and improved accuracy ←

← Easily processed information at a glance ←

← Design allows for hanging, for improved viewing angle ←

Excessive luxury is not our goal. But we feel that luxury doesn't mean "more," it means "proper." Proper design, proper fit, proper precision—what Audi thinks of as design purity. Our engineers and designers know that a baroque clock won't tell time any better than a streamlined one, and all the distractions that surround it actually detract from the purpose of the clock itself. Unless, of course, the purpose is just to be noticed, instead of used to its greatest

potential. We think the real purpose of design is simplicity, elegantly rendered. We think you'll see and feel that concept throughout our Audi models. In the clean design lines of the exterior, the streamlined dash, and Audi MMI® interface. In our intuitive available Audi connect®¹, the seamless fit and finish of our materials and the unmistakable look of our Audi Singleframe® grille.² They all work in concert for a pure aesthetic of timeless taste and precision.

It's Audi because

our reputation hinges on the quality of things you don't see.

It's said that when one door closes, another one opens. It sounds as if whoever said it spent some time at an Audi research and development facility. After all, while you'll open and close the door on your Audi thousands of times without thinking about it, we've obsessed about it for you, in detail. Not just about the reliability of it opening and closing, obviously, but on the proper weight that will make it more pleasing to close. What it should sound like when it is shut. How the locks should click when they are engaged. The optimal acoustic placement for the speaker port. There are the

hinges too, of course. And the door itself, which is designed to take the brunt of side-collision impacts, along with several dozen other considerations that we take into account when designing our doors (to say nothing of the countless other components, processors, sensors, features and the inner workings most people will never see). Our doors are more than a symbol of welcoming you into your vehicle, they are products of Audi engineering, and our reputation hinges on them as much as our hinges help support the door.

Award-winning design

When Audi engineers set out to build the perfect door, they had one very important goal—lighten the load. By using fully pressed aluminum doors, the weight of the Audi A6 door structure was reduced by an astonishing 44 lb, compared to the previous model. This feat, combined with the strength of its door hinges and ability to retain all of its mechanical, safety and infotainment features, is why it won the Doors and Closures Innovation Award.

Acoustic enhancements

We spend countless hours listening, so you don't have to. By using soft-mounts on our window regulator, or a sound absorber backing within the door cavity itself, as well as a simple foam liner on our door-release cable, Audi engineers have nearly eliminated all of the ambient noise associated with other less-than-acute manufacturing practices.

Speaker placement and enclosure

We work with our partners to select optimal placement of our speakers, a vital aspect of our door design, in order to deliver the most engaging and extraordinary sound you can find in the automotive space. Woofers use a specialized lightweight and ported enclosure to ensure optimum low-frequency reproduction.

40% ← Asymmetric torque split^{1,2} → 60%

Sport differential²

Torque vectoring²

You'll find truth in your corner. Torque vectoring is a handling feature so advanced that it seems to respond to your impulses even before you turn the steering wheel. An evolution of cross-axle lock, this system works within the Audi quattro® all-wheel drive system while utilizing Electronic Stability Control (ESC) and the Anti-lock Braking System (ABS) to help sense reduced load or wheel-spin on the inside cornering tire, helping to make turns smoother and more responsive.²

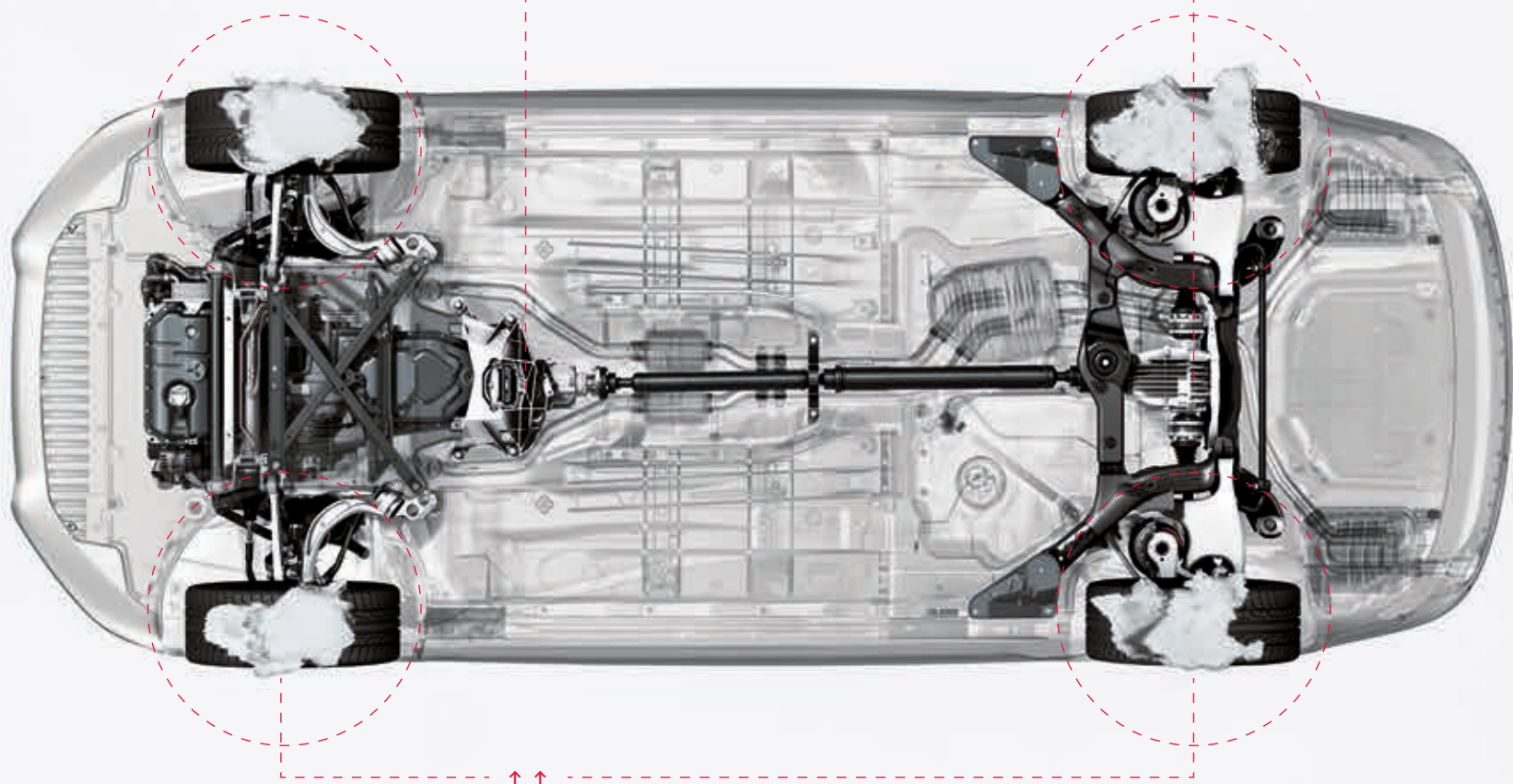

It's Audi because

conditions don't have to dictate how you stick it to the road.

As you can see, we've always felt that the best ideas are the ones that stick. And nowhere is that more true than with Audi quattro® all-wheel drive. Since 1980, we've been stuck on articulating an expanding vision of what progressive all-wheel drive technology can deliver. We didn't simply look at it as something to use in poor conditions, but rather as a performance technology that's built to handle roads from the Alps to the autobahn—and points beyond. You've seen quattro® capabilities in the way we dominated the World Rally Championship for years, in the grip you have in inclement weather,

and in the variable rear-wheel-biased power you enjoy in good conditions.¹ For more than 30 years and with five million quattro® systems installed in Audi vehicles, we have continued to refine the technology, developing a rear sport differential to help maximize performance, and torque vectoring to assist with cornering traction while helping to improve handling.² We boldly stuck to what worked while the world was trying to catch up, and we built on our vision by adding to a gripping heritage of Audi Sport® performance.

European model shown with optional equipment. 1 Torque split ratio will vary from model to model. 2 Optional features. Features and technologies listed will not be available on all models.



—

Ants can carry up to 50 times their body weight. That got us thinking about lightweight structures, smart engineering and true performance.

It's Audi because

power is measured by strength, not size.

It's perfectly fine for us to admit that other engines have more cylinders, have more horsepower and have larger displacements. It's just that we've made our engines lighter and more efficient than others, to optimize what we call power density.¹ Because anyone who has driven an Audi knows unmistakable power when they feel it. It means strength that pulses with torque at the moment of acceleration, provides a true, quick response as you change lanes, and turns the most routine cloverleaf into a joyful application of performance

handling. Sure, we love hitting the throttle and feeling the thrust of acceleration;² but we also want our drivers to experience the balance and precision of Audi engineering. From the A3 to our track-bred line of Audi performance cars, we are in the business of engineering emotion using more compact engines that concentrate power, while using less weight to your advantage, helping improve handling to the point where others just feel heavy.

TDI®

A turbocharged, fuel-sipping variant, our TDI® clean diesel engine delivers uncompromising Audi performance with bold efficiency.¹ Yes, it gets better mileage per gallon than comparable gasoline engines, but it also produces more low-end torque, which is best expressed in the elasticity you have when passing in the 30- to 60-mph range.

FSI®

The Audi FSI direct injection fuel management and delivery system directly injects fuel into the combustion chambers at precisely managed times and depths. What that means for drivers is that a fully homogenized intake charge helps increase power while also reducing fuel consumption and emissions, making efficiency more powerful.¹

TFSI®

At Audi, TFSI represents a combination of two of the brand's core areas of expertise—direct injection and forced induction. By adding forced induction (turbocharging or supercharging) to Audi FSI direct injection, the pressurized intake charge is cooled by directly injected fuel, thus achieving efficiency and performance combined with higher compression ratios—previously only attainable by naturally aspirated engines.¹

¹ See www.fueleconomy.gov for EPA estimates. Your mileage will vary. ² Obey all speed and traffic laws.



Mobile Wi-Fi® hotspot

Provides high-speed connectivity for up to eight passenger devices through an onboard wireless hub.^{1,3}



City events

Get information about current events, exciting locations and places of interest at your travel destination, current location or other chosen location instantly.³



myAudi features

Plan travel from your personal computer. Send your desired destinations to your vehicle ahead of time and access your route from your vehicle later.³



Google Voice™ Local Search

Simply tell your Audi what you are in the mood for, then let the cloud-processing power of Google™ speech recognition interpret your request and bring up a list of destinations in the area of your choice.³



Google Earth™ with 3D satellite imagery

With Google Earth™ integration, you'll enjoy 3D satellite imagery, including Google Maps Street View, displayed right on the Audi MMI display.³

It's Audi because

spicy chicken is your destiny.

If you are craving an Audi, we know your tastes run a little bold. But what happens when you crave spicy chicken, or a nice vindaloo, or some pepper salsa? Well, in your Audi, you can just say the word, and we'll help find the heat. With available Audi connect®,¹ we've developed a way to seek out your destiny, even if that's just finding the closest gas station, or the best hotel. Audi connect integrates Google™ technolo-

gies, like Google Earth™ with 3D satellite imagery, with Audi MMI® Navigation plus.² It also provides Wi-Fi® connectivity for up to eight passenger devices to help you stay informed. Check local fuel prices, weather information and, yes, the closest Szechuan restaurant using Google™ Local Search capabilities. Think of where that might take you.^{1,3}

1. Always pay careful attention to the road, and do not drive while distracted. The features and technologies discussed above are optional, may require an additional subscription with separate terms and conditions, and should be used only when it is safe and appropriate. The Wi-Fi® hotspot feature is intended for passenger use only. 2. Audi MMI® Navigation plus depends on signals from the worldwide Global Positioning Satellite network. The vehicle's electrical system and existing wireless and satellite technologies must be available and operating properly for the system to function. The system is designed to provide you with suggested routes in locating addresses, destinations and other points of interest. Changes in street names, construction zones, traffic flow, points of interest and other road system changes are beyond the control of Audi of America, Inc. Complete detailed mapping of lanes, roads, streets, toll roads, highways, etc., is not possible, therefore you may encounter discrepancies between the mapping and your actual location. Please rely on your individual judgment in determining whether or not to follow a suggested Audi MMI® Navigation plus route. Periodically mapping updates will be available for purchase at an additional cost. Consult your dealer or call 1-800-FOR-AUDI for details. 3. Optional features. Features and technologies listed will not be available on all models.





Elephant skull

How nature solved the apparent conundrum of an elephant's skull didn't escape the notice of Heinrich Timm, the longtime lead engineer for Audi. The weight of the tusks and the general size of an elephant's head would seem to make it impossible for the animal to actually be able to carry it. But the design genius behind the elephant's skull is actually to make it lightweight, yet sturdy. Its predominantly hollow design is buffered by thin, connective bone walls, which act as strong, weight-bearing cells. Audi designers used that idea when building our aluminum and steel structures. Reducing weight, yet enabling strength.

Aluminum

Our large aluminum castings are a telling example of Audi ultra® lightweight technology. Primarily used in high-stress areas, these multifunctional castings achieve exceptional rigidity while also allowing for freedom of design, all while remaining extremely lightweight.¹

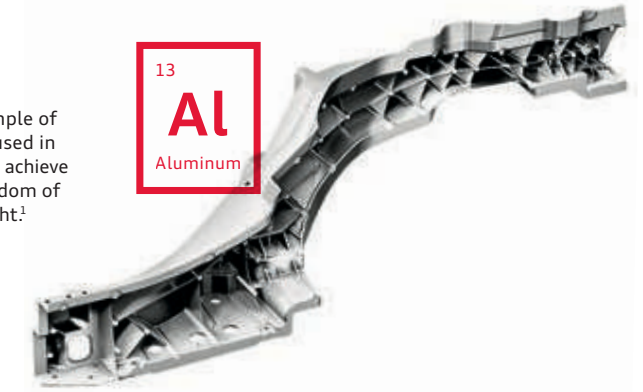

It's Audi because

the elegant structure of nature becomes a blueprint of efficiency.

It seems strange to say that, while we build strong, complex and high-performing machines, we're naturalists at heart. Then again, it might not be that unusual, seeing how nature itself builds strong, complex and high-performing machines as well. When we developed the thinking behind our Audi ultra® lightweight technology initiative, we knew that nature would serve as an inspiration to greater structural efficiency. Take the structure of the elephant skull pictured here. It has to be lightweight, yet capable of carrying a heavy load. It's porous, but its structure is such that it enhances its stability and

strength. We do the same, for example, with aluminum. Positioned one way, aluminum materials can be flexible. Positioned another, they are strong and rigid, and give better support. We also looked to bamboo, which is strong at the conjoined areas (nodes), and flexible along its stem. Our designs allow for both rigidity and flexibility where each is most needed, and for efficiency overall.² As we continue to develop strategies to improve the performance aspects and efficiency of our vehicles, we don't shy away from the world around us.² We boldly engage it even closer still.

¹ Features and technologies listed will not be available on all models. ² See www.fueleconomy.gov for EPA estimates. Your mileage will vary.



It's Audi because

you I.D. our eye queue.

Even if you knew nothing about Audi, you'd still know if you were staring at one because we are unafraid to stare back. In fact, that exchange might just be love at first sight. That's how much our iconic LED lighting technology stands out from the pack. So we had the bright idea to make our LED daytime running lights look even more in-

tense. Now featuring a solid, sleek diode design that ingeniously reinvents our signature style, Audi LED lighting technology is once again unmistakably ours. It is an efficient, beautiful way to help you see and be seen during dawn and dusk. Look deeply into our eyes, and you'll know the truth of our attraction.¹

¹ Features listed are available on all models.



1 Steering wheel

The Audi steering wheel is both an ergonomic command center and an elegant structure of performance. Easily accessed controls on the wheel give you control over your MMI® and Audi connect®, while it is designed to give you effortless access to visual information on the driver information display.^{1,2}

2 Audi connect and MMI

Simple voice or finger motions can help you access information, music and BLUETOOTH® enabled features.^{1,2}

3 Electromechanical parking brake

Properly positioned in the center console, the parking brake control is another small, but telling, design cue for Audi. The parking brake control serves to enhance the overall ergonomic intent of the vehicle, while delivering easy access and simple functionality.¹

4 Bang & Olufsen® Advanced Sound System

With retractable acoustic lenses and speakers positioned around the Audi specifically to optimize sound quality, Bang & Olufsen® engineers have worked tirelessly with Audi sound designers to create an immersive audio experience.¹

It's Audi because

optimized design makes your commute shine a little brighter.

Get away from it all, every day, around 6 p.m., when you leave work and enter into a customized world that's completely dedicated to your comfort and entertainment. This place, of course, is the cabin of your Audi. Optimized luxury, designed by committed craftsmen who have you in mind when they choose the leather seating surfaces, create the adjustable seats or provide the refinement of ergonomic design and a more intuitive MMI. There are small touches that help simplify the overall design, like a

stylish contoured electromechanical parking brake at the foot of the center stack and an available Bang & Olufsen® retracting acoustic lens, perfectly positioned for richly detailed sound quality. And there are large statements, like a steering wheel with easily accessed controls to help you feel comfortably at ease. It is your Audi interior, where you leave the world behind, even when the world might seem in front of you on the way home.¹

1. Optional features. Features and technologies listed will not be available on all models. 2. Always pay careful attention to the road, and do not drive while distracted. The features and technologies discussed above are optional, may require additional subscription with separate terms and conditions, and should be used only when it is safe and appropriate. The Wi-Fi hotspot feature is intended for passenger use only.

It's Audi because

it's as if we have SPF for seats.

With innovative pigments and dyes, the Thermocool technology Audi uses in select leather seating surfaces just might prevent that startling moment on hot sunny days. You know the one, when you sit down and feel, immediately, an intense, searing feeling on your leg. Now you can keep your cool. This supple leather doesn't heat up as

much in direct sunlight as traditional leather does. In fact, the difference between untreated leather and the temperature on your seat treated with Thermocool can be as much as 86°. A perfect solution for your Audi A5 Cabriolet, TT Roadster or R8 Spyder, Thermocool technology is Audi to its core. Because it keeps its cool, you can keep yours.



Reduce as much as **86°F**

¹ Images shown are for dramatization purposes only.

THE PASSIONS OF AUDI

The story of our collection of obsessions.

Precision. Design. Vision. These are the kind of attributes that we deliver as a company, the kind of passions that go way past getting you from point A to point B. That's because Audi knows that how you get to your destination is only part of the story. And so it is with us as a luxury brand. Our obsessions are our commitments, a collection of inspirations that make up our core truth: That from a foundation of brilliant engineering, we craft more than great vehicles—we tell great stories.

allroad

There's a reason adventure is so appealing.

Take a moment to dive into the finer details of Audi. Here you'll find a vehicle that defies conventional thinking every step of the way. From a healthy sense of adventure to a passion for the finer things in life, the Audi allroad® always stays one step ahead of its peers. It's a stunning example of what legendary engineering, generous luxury and exceptional design can accomplish together.

BE CAUSE



Enlighten

Shedding a new light on illumination just happened to be a design boon.

In season, no matter the month.

There's something to be said for acting on an impulse. When the itch for adventure hits, you don't waste any time—you just pack up your Audi allroad® and go. Of course, with so many recreational opportunities afforded by the allroad, it doesn't take an advanced degree in mathematics to figure out that acting on every impulse could mean a very busy schedule. Luckily for you, you'll have the benefit of an increased ride height, widened track, surefooted Audi quattro® all-wheel drive, and a potent yet efficient 2.0-liter Audi engine at your beck and call.¹ All while the stylish and iconic available LED daytime running light technology provides your allroad with an unmistakable look. And just because you may plan on roughing it when you reach your destination doesn't mean you and your passengers can't indulge in a little opulence on the way. Whatever activity the calendar calls for, you can count on the Audi allroad to be ripe with readiness.²

¹ EPA estimates not available at time of printing. See www.fueleconomy.gov for updated information. Your mileage will vary. ² When driving during cold, rainy, snowy or icy weather conditions, ensure that your vehicle is equipped with appropriate all-season or winter tires. Even with appropriate tires, you must always drive in a manner appropriate for the weather, visibility and road conditions.





Design

We do not change design standards. We author them.

True beauty takes its own path.

It may be its muscular silhouette that first captures your imagination, or maybe it's the way its increased ride height tells a story of adventure off the beaten path. Whatever it is, you know it didn't arrive here by following others. That's why it's possible to stare at the Audi allroad® for hours and still not pinpoint its most alluring feature. So let us offer some insight. Something we call the Tornado line draws your eye along a flowing path from front to rear. This line, combined with the flared fenders and robust aluminum roof rails, adds to its magnetic appeal. And while it may be difficult to pin down, its beauty is a product of blazing its own trail.



Electronic Stability Control with Off-road mode

Detecting loss of traction almost immediately, ESC helps you stay pointed in your intended direction by automatically adjusting the throttle and brakes. And when activated, the Off-road mode can sense changes in terrain, and varies ESC assistance to help optimize control.



Blurring the lines between roughing it and pampering.

Traditionally, one would never equate a trek into the wilderness to a relaxing day at the spa. Then came Audi allroad®, where you'll be hard pressed to tell the difference between becoming one with nature and immersing oneself in exquisite luxury. Just imagine settling in on the supple, leather-appointed seating surfaces. From this comforting position, you'll notice how the simple, intuitive controls are all within an easy arm's reach, and the available Fine Grain Ash Natural Brown Wood decorative inlays establish a serene, Zen-like atmosphere.

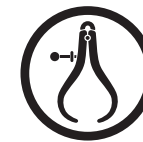

Craftsmanship

We've ensured that every stitch represents the detail that we put into every aspect of an Audi.



Cavernous interior

With the convenience of an available power tailgate, up to 50.5 cu ft of cargo capacity and split folding 60/40 rear seatbacks, the question of bringing more luggage or more toys has been answered. Bring more of both!¹

¹ All cargo should be properly secured before driving the vehicle. See your owner's manual for details.

Our terrain is not defined by topography.

The luxurious Audi allroad® was designed with SUV capabilities in mind. That means, luxury aside, those gravel-strewn switchbacks and steep, graded highways are effortless terrain for the Audi quattro® all-wheel drive system. Audi quattro® is designed to help provide maximum grip and optimized power delivery for practically all sorts of road conditions. So while your commute may not be as thrilling as a trip to the summit, you can be confident in the balance and enhanced performance Audi quattro® offers you wherever you go, while giving you no good excuse for taking a snow day.¹



▼ 56°F to 78°F



↑

All-around confidence

Just like life, the road can throw you a curve. So throw one right back with the superior grip and control of quattro®. It helps provide the performance and confidence you would expect from Audi, no matter if you're commuting in the city or crisscrossing the country. This is advanced engineering you can live with.



¹ When driving during cold, rainy, snowy or icy weather conditions, ensure that your vehicle is equipped with appropriate all-season or winter tires. Even with appropriate tires, you must always drive in a manner appropriate for the weather, visibility and road conditions.



▼ HUMIDITY 95%

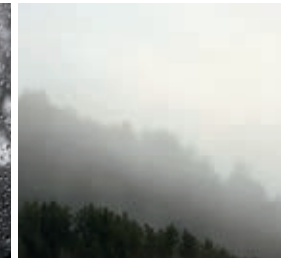

↑

All-weather capability

There is a reason quattro® is considered such a friend in foul weather. Under normal driving conditions, the center differential splits torque at a ratio of 40:60 front to rear, but as conditions change and become more challenging, the ratio is optimized to help maximize grip. And with the ability to transfer the majority of available torque mechanically to the wheels with the most grip, the operation is exceptionally smooth, even under extreme conditions.¹

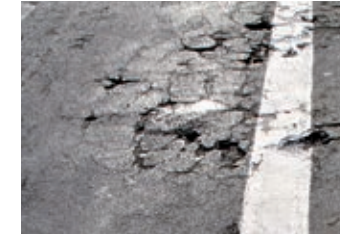

↑

Torque vectoring

It's a handling feature that seems to respond to your impulses before your steering input. An evolution of cross-axle lock, this system works within quattro®, while utilizing ESC and ABS to help sense traction loss from the inside cornering tire.



↓

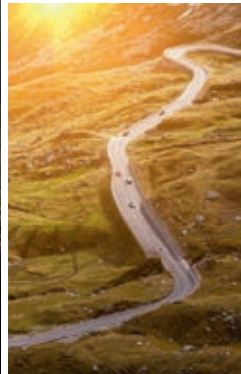

▼ WIND 54 mph

It's not just a catchy name.

We don't just make beautiful cars. We make them with purpose. And when you consider the ultimate purpose of the Audi allroad®, it should come as no surprise that it's equipped with rugged features that even the most hardened adventurer can appreciate. But not every day will be spent exploring long-forgotten roads. That's why these features are meant to be just as striking in an urban landscape as they are useful on an extended camping trip.

Roof rails

With the standard raised aluminum roof rails, the possibilities for multiple activities open up. Whether your trip calls for a ski carrier, a bike carrier or a luggage carrier, there's an attachment for it!



Underbody protection

Stainless steel underbody protection not only helps serve as a barrier between your allroad and errant rocks, but adds to its timeless, artistic beauty.



Specialized tires

With an increase in tire sidewall height, the allroad has the perfect combination of useful ground clearance and impressive, all-terrain capability.



Ride height

Obstacles to your journey can be overcome easily with the increased ride height. With over seven inches of ground clearance, there's more than enough to help get you out there and back.

Cladding

Just in case anyone was unsure about this vehicle's capability, the allroad features robust exterior cladding, making its intentions clear. And with an available full-paint finish, its refinement is just as apparent.

¹ All roof-rack system attachment accessories require the base carrier bars. All sold separately.

We don't anticipate your response so much as provide it.

At Audi, we believe you should be the ultimate master of your road-going domain. That's why we created the available Audi drive select system. It gives you the ability to adjust the vehicle's steering, throttle response and transmission shift characteristics with the utmost of ease. And with four modes to choose from, no matter what kind of road comes into question, Audi drive select will let you answer.

1

Comfort mode

Perfect for less-than-perfect roads, this setting adds optimized steering and a closer shift pattern to help provide a more relaxed drive.

2

Dynamic mode

Tighter steering and a more responsive throttle give this setting an aggressive feel and focused performance.

3

Auto mode

The best of both worlds, dialed to automatically adjust settings for a seamless combination of comfort and responsiveness based on your driving style and road conditions.

4

Individual mode

Take the turn your way—this mode allows you to adjust the steering, throttle and transmission upshifts to your style.



Transmission

From very responsive, quick gear changes to more gradual acceleration, the transmission is at the heart of Audi drive select.



Throttle-mapping

Depending on the mode of Audi drive select you choose, the throttle can be precisely responsive or a little less so.



Steering

When you turn the steering wheel, you expect the vehicle to react accordingly. Audi drive select helps give you more input on how that will feel.

Under pressure over efficiency.

There is an old school of thought in the automotive world that bigger is better. More horsepower, greater displacement—these were once the hallmark of the industry. Audi, on the other hand, progressed past this antiquated notion of engine design and adopted a system that refines the driving experience. By utilizing lightweight turbocharged engines, we solved two problems at the same time: greater efficiency and more power than was produced by previous engines.¹ And since lighter vehicles breed better performance, the result is an exhilarating driving experience at every turn.

2.0 TFSI® four-cylinder

This 2.0-liter turbocharged DOHC engine produces 220 horsepower and 258 lb-ft of torque, and combines the valvelift system, Audi FSI® direct injection and turbocharging for great power and overall efficiency.¹

air out to intercooler
↑ ↑ ↑ ↑ ↑ ↑ ↑ ↑

220 horsepower
258 lb-ft of torque
Maximum boost pressure: up to 17.4 psi

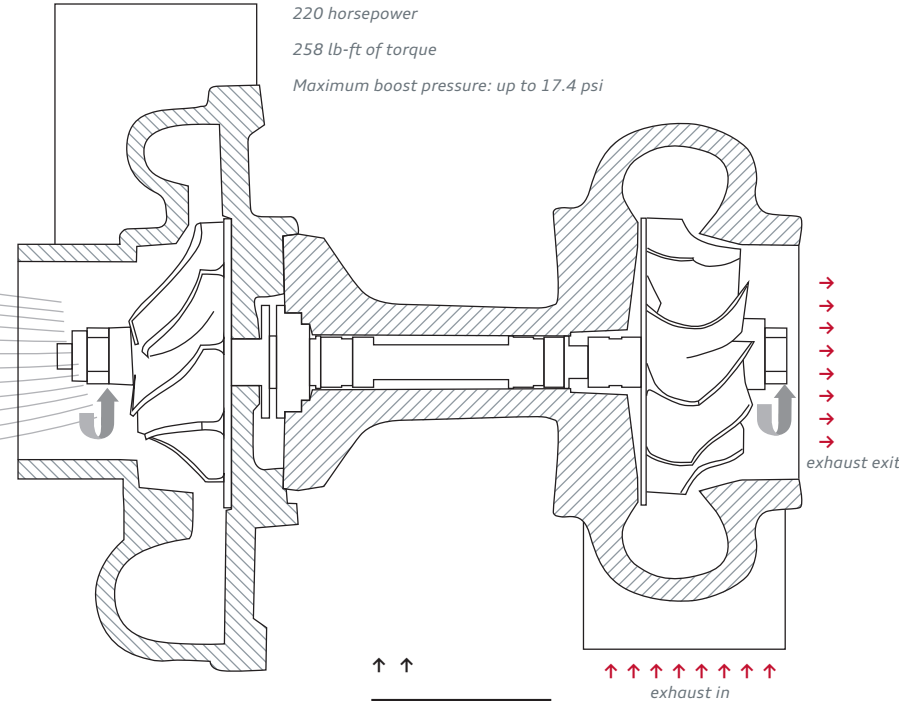

↑ ↑

Exhaust gas intake

Exhaust from the engine spins the turbine that is connected by a shaft to a compressor that pressurizes air. The compressor forces this pressurized air into the cylinders at boosted pressures up to 17.4 psi, thus producing more power from a smaller displacement engine.



Performance

The adage “good things come in small packages” has never been more true.

Induction-technology turbocharger

Compressing the airflow to the engine allows more air into the cylinder and, ultimately, more power from each combustion cycle, significantly improving the engine’s power-to-displacement ratio.

Eight-speed Tiptronic® automatic transmission

As the perfect compromise between a dedicated manual and an automatic gearbox, the eight-speed Tiptronic® automatic transmission in the Audi allroad® offers eight optimized, carefully chosen gear ratios. Selected automatically or via its console-mounted shifter or steering wheel with available shift paddles, precise shifts are delivered without sacrificing the smooth action of the Tiptronic® automatic. A high final drive ratio allows optimization of lower gears, yet the transmission’s upper range emphasizes fuel economy—particularly at highway speeds.¹

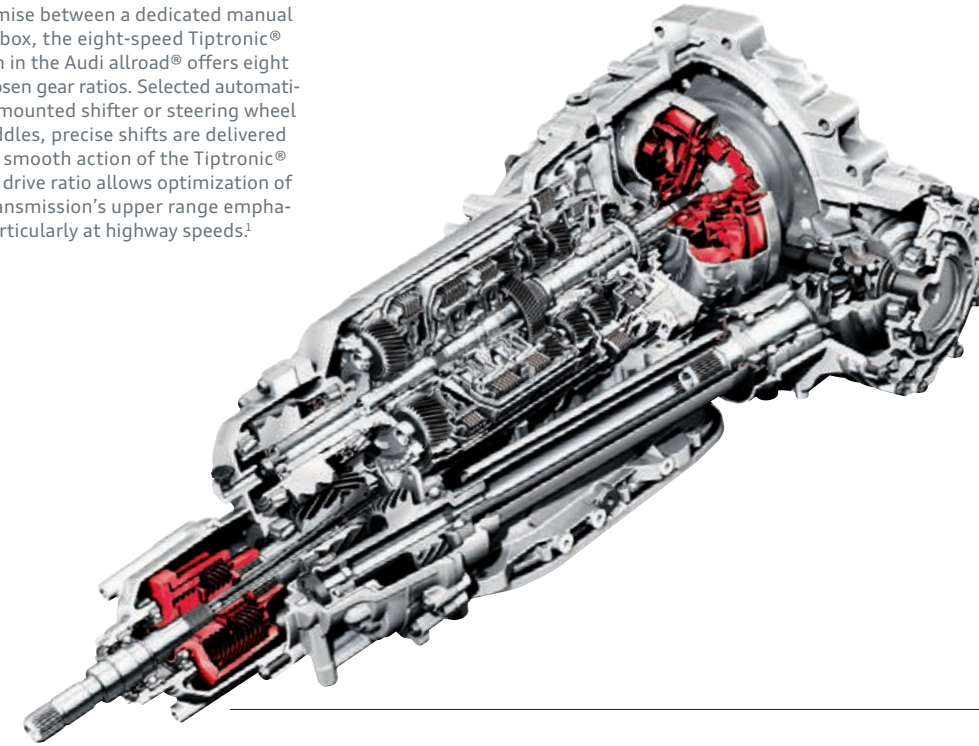

gear	ratio
1ST	4.714:1
2ND	3.143:1
3RD	2.106:1
4TH	1.667:1
5TH	1.285:1
6TH	1.000:1
7TH	0.839:1
8TH	0.667:1

Driving to the tune you choose.

The Audi allroad offers an eight-speed Tiptronic® automatic transmission that precisely transmits the power produced by the 2.0-liter TFSI® engine. With its wide gear ratios for smooth shifting, it doesn’t matter which gear you’re in, you can count on seamless power delivery. Available steering wheel-mounted shift paddles let you shift up or down with minimal effort, while giving you the control that performance drivers crave. A shift has been made in your favor. What you do with it is your choice.

¹ EPA estimates not available at time of printing. See www.fueleconomy.gov for updated information. Your mileage will vary.

We shed light on your blind spots.

With a suite of available driver assist options, we strive to constantly up the ante on driver convenience. Available Audi side assist helps inform you of other vehicles in the lanes next to you, while available Audi adaptive cruise control helps monitor the distance between you and the vehicle ahead, and adjusts your speed appropriately to keep you moving smoothly. There are also the simple things, like parking system plus, which adds a rear view camera and rear acoustic parking sensors to help ease you into that spot. It's another testament to the effort that Audi puts into helping ensure that you're not the only one keeping an eye on the road.



Audi adaptive cruise control

Everyone has their own comfort zone. The available Audi adaptive cruise control helps maintain a driver-selected distance from the vehicle in front by using a special long-range radar sensor. The system constantly measures the space between your vehicle and the vehicle ahead and helps maintain it by automatically adjusting your speed. Once the road ahead is clear, the vehicle effortlessly resumes the previously preset speed, helping to make your drive that much more relaxing.



Driver Assist

We're solving problems before you even know you have them.

Audi side assist

The available Audi side assist uses radar sensors and two different optical warnings to help keep the driver informed about what is approaching from hard-to-see angles behind and to the side of the vehicle.

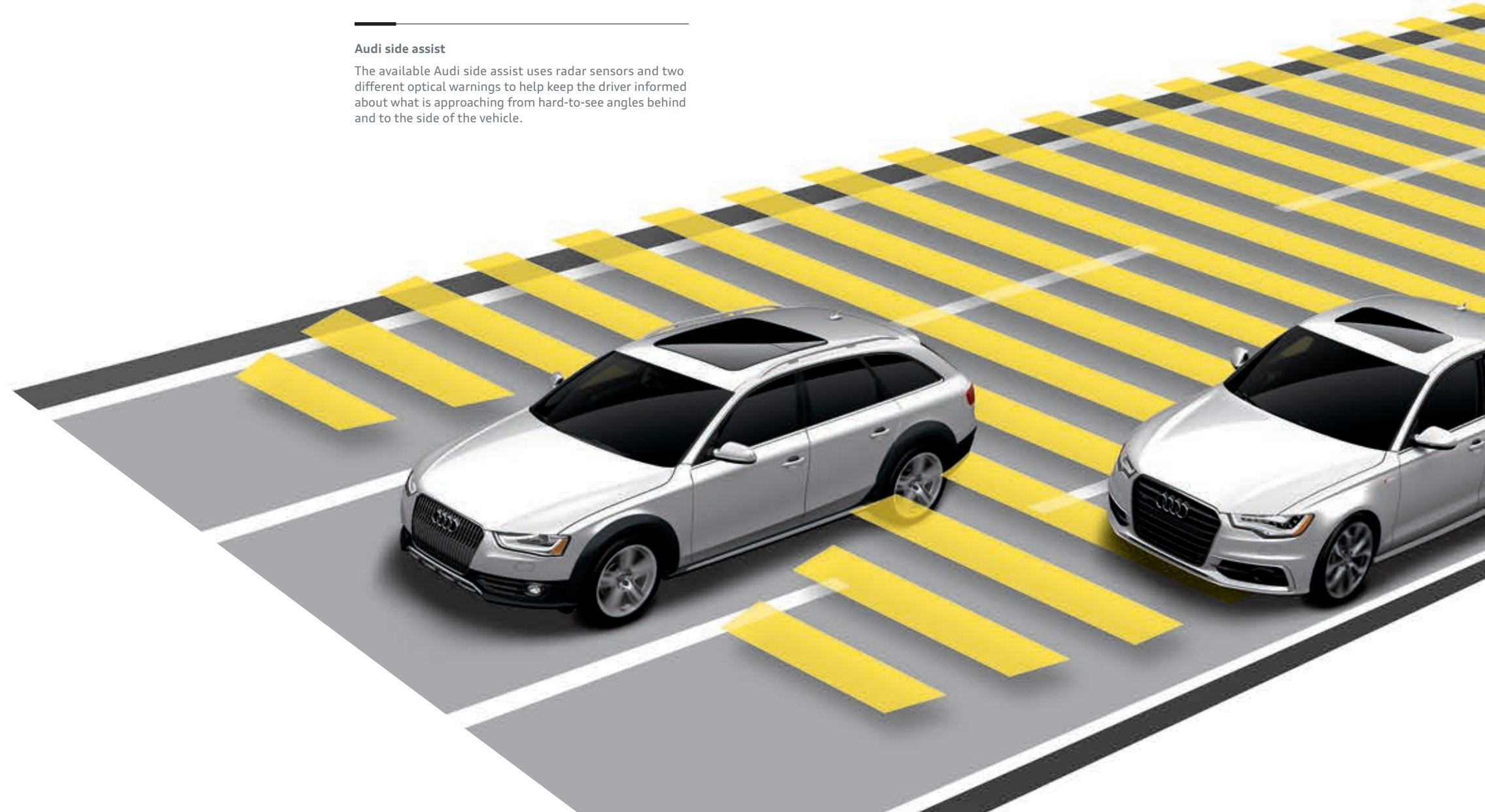

Car consciousness.

We believe intelligence is key to a higher form of luxury. You can see this philosophy fully represented in the available Audi MMI® system. Simply put, it's an intuitive system that intimately connects you to almost every facet of the vehicle. It's the nerve center of your vehicle, allowing you to control virtually every interior function of your Audi with a simplified source control button system. From the Audi MMI Navigation plus, to the sound system, to media, MMI helps you access information with a few easy clicks. And even without it, you can pair your compatible phone with the vehicle for added convenience. With this kind of brainpower onboard, you can leave the little stuff to us, and just concentrate on how good it feels to drive.



MMI System

We've brought the backseat driver front and center.

SiriusXM® Satellite Radio

Go ahead. Crisscross the country. We assure you, you'll never run out of entertainment options, with over 130 channels of music, talk, sports and news.¹

Audi media

The media function opens up a world of options when equipped with the Audi MMI Navigation plus, allowing you to control the Audi music interface, Secure Digital (SD) card slots, hard disk drive (HDD) audio jukebox or DVD, and BLUETOOTH® streaming audio.^{1,2,3}

Audi MMI Navigation plus

Count on the available advanced navigation system to home in on your destination with stunning precision while putting a little more depth in your journey with help from Google Earth™.¹

BLUETOOTH® wireless technology

Unlock your mobile phone's potential through the MMI system. Simply pair them up and start enjoying near complete control at the touch of a button.³

¹ See Infotainment/Technology section of the Featured Content page for important information regarding Audi MMI® Navigation plus and required SiriusXM® subscriptions. ² Always pay careful attention to the road, and do not drive while distracted. The features and technologies discussed above are optional, may require an additional subscription with separate terms and conditions, and should be used only when it is safe and appropriate. The Wi-Fi® hotspot feature is intended for passenger use only. ³ Requires compatible phone.

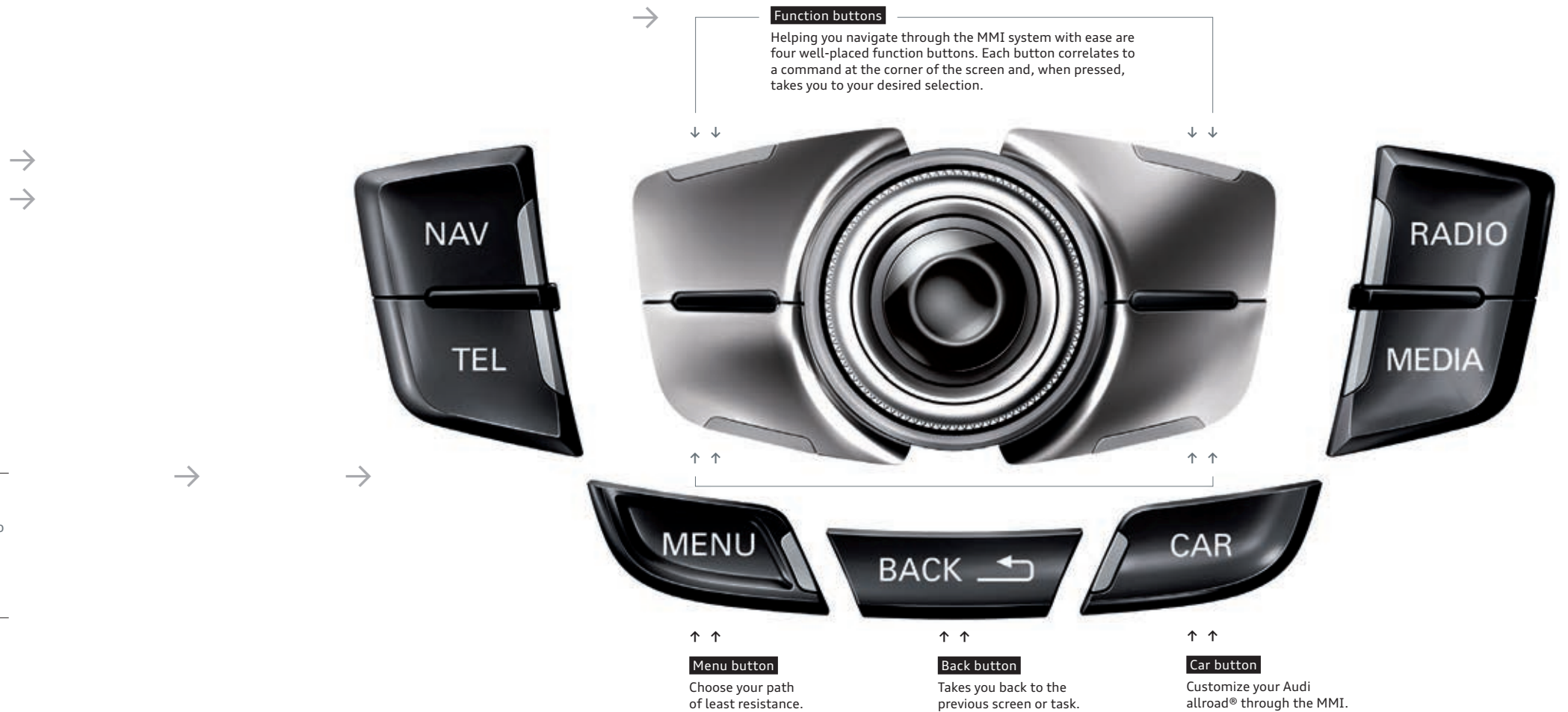

If nothing else, you know your car is listening to you.

Don't reach—relax. While touchscreens are seemingly everywhere, they don't need to be in your vehicle. With available Audi connect®, you may never have to reach out again.¹ Thanks to Google Voice™ Local Search, Audi connect allows you to search Google™ by simple voice commands. The crisp display is nestled farther up, closer to the windshield, so your eyes don't have to focus and refocus between the screen and the road ahead of you. For those times when you are feeling tactile, we've placed toggle buttons near the gear shifter, where your hand naturally rests while you drive. So while other automobile manufacturers still want you to reach out, we've found a few ways for you to make information a lot more accessible while your hands are on the wheel.

POI

Point-of-interest

The point-of-interest search with voice control means that the digital world is with you on every journey.

myAudi

myAudi features

Plan travel from your personal computer. Send your desired destinations to your vehicle ahead of time and access your route from your vehicle later.

NEWS

News feeds

Stay on top of the news by having headlines and stories delivered right to your Audi MMI® display.



Mobile Wi-Fi® hotspot

Provides high-speed connectivity for up to eight passenger devices through an onboard wireless hub.



SiriusXM® Traffic

Get traffic information overlaid onto 3D satellite imagery to visualize a true aerial view of your route, and let the Audi MMI Navigation plus system reconfigure your route to avoid traffic.²



Google Earth™ with 3D satellite imagery

With Google Earth™ integration, you'll enjoy 3D satellite imagery, including Google Maps Street View, displayed right on the Audi MMI display.



Weather information

Current local conditions and forecasts for your destination can help you prepare for your trip.



Google Voice™ Local Search

Simply tell your Audi what you are in the mood for, then let the cloud-processing power of Google™ speech recognition interpret your request and bring up a list of destinations in the area of your choice.



Google Maps Street View

With Google Maps Street View, your vehicle can show you a driver's-eye view of your destination right before you arrive so it's easy to recognize.



Parking information

Search for parking in your area of interest, check space availability and set your selection as a destination to navigate directly to the garage entrance.



City events

Get information about current events, exciting locations and places of interest at your travel destination, current location or other chosen location instantly.



Travel info

Discover local landmarks in your area of interest, set them as your destinations, and let your vehicle lead the way as you explore the world around you.

¹ Always pay careful attention to the road, and do not drive while distracted. The features and technologies discussed above are optional, may require an additional subscription with separate terms and conditions, and should be used only when it is safe and appropriate. The Wi-Fi® hotspot feature is intended for passenger use only. ² See Infotainment/Technology section of the Featured Content page for important information regarding required SiriusXM® subscriptions.



Sound

Audi is Latin for "listen," so you know we take sound very seriously.

When even a German lullaby is an ode to sound engineering.

It would be an interesting challenge, a note-perfect Brahms' Lullaby delivered through the tuned speakers of an Audi concert radio system versus the exhilaration of the passing lane. Either way, performance wins. But it goes way beyond the gentle tones of a German composer. Audi sound engineers don't simply make the cabin acoustics sound perfect for your music, they make the drivetrain sing. Or, if not sing, then put it in harmony with every other element of the driving experience. From the sound of a shutting door, to the click of a turning knob, to the full integration of an available Bang & Olufsen® Sound System, there's an orchestra of engineering that fills your cabin with faithfully rendered, thrilling sound. Whatever it is you are looking for, Audi sculpts sounds in a way that matches your mood, even when you need soothing while in traffic.

Bang & Olufsen® Sound System

Dedicated to the idea of "honest music reproduction," Bang & Olufsen® is a sound engineer's dream. Through an available 505-watt, 14-speaker system perfectly integrated within your Audi, Bang & Olufsen® is set on transcending the limits of audio technology. By automatically adjusting volume and timbre balance to changing ambient noise levels, and offering richly tuned acoustics, you'll hear the truth about how good life can sound in your Audi.

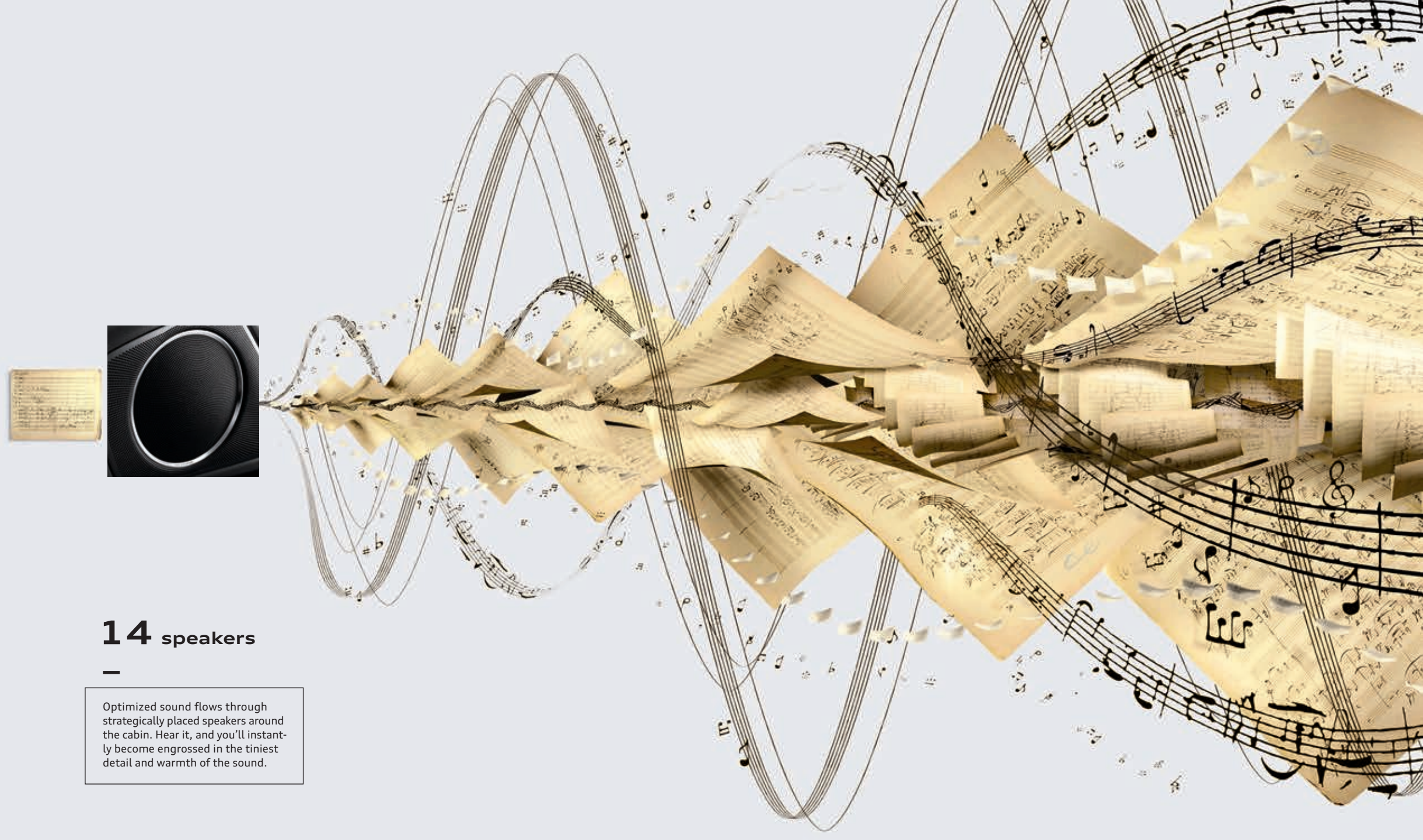

14 speakers

Optimized sound flows through strategically placed speakers around the cabin. Hear it, and you'll instantly become engrossed in the tiniest detail and warmth of the sound.



LED taillight technology

Sleek and stylish, these rear light-emitting diodes are brighter and longer-lasting than conventional bulbs, and also illuminate faster than traditional brake lights, which can help give the driver behind you more time to respond.

A brilliant indication you are on the right trail.

Distinct and brilliant, available LED taillight technology will be the first indication to other outdoor enthusiasts that they are finally headed in the right direction. And, as if that were not enough to hurt their map-reading egos, the mesmerizing design of the Audi allroad® comes to an irresistible climax around two perfectly sculpted exhaust tips, invoking jealousy to go along with the steady stream of profanity issuing, perhaps, from those who are less directionally inclined. At least you'll give them a lot to think about while they try to keep up with you.

Exterior Colors | Cladding | Wheels

Brilliant Black

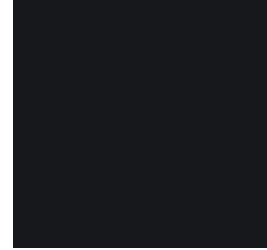

Ibis White

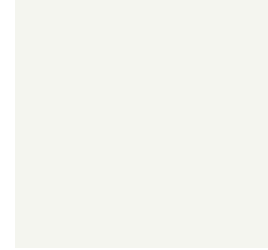

Cuvée Silver metallic

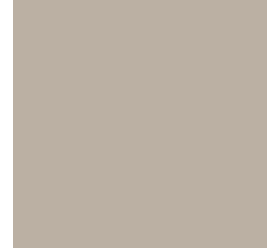

Dakota Gray metallic

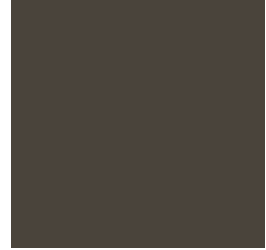

Glacier White metallic

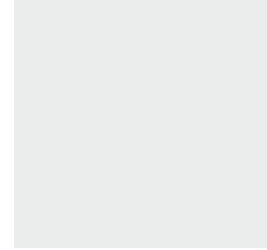

Full-paint finish (optional)

Ice Silver metallic

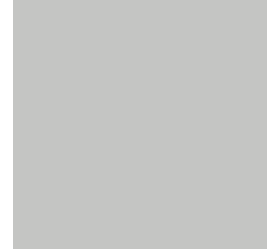

Full-paint finish (optional)

Monsoon Gray metallic



Moonlight Blue metallic



Scuba Blue metallic



Volcano Red metallic



Phantom Black pearl

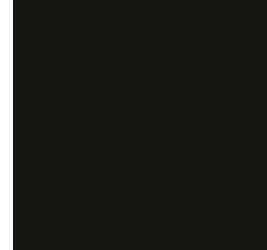

Full-paint finish (optional)

18" 5-arm-allroad® design
245/45 all-season tires



allroad Premium, Premium plus and Prestige

19" 5-arm-structure design
245/40 summer performance tires¹



allroad Premium plus and Prestige (optional)

Interior Colors | Seat Selections | Decorative Inlays

Standard Seat



Sport Seat



Black leather



Standard, Sport

Titanium Gray leather

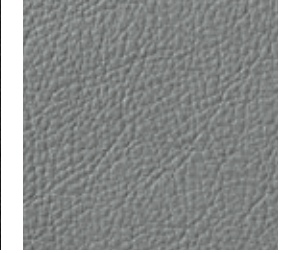

Standard, Sport

Chestnut Brown leather



Standard, Sport

Velvet Beige leather



Standard

Aluminum Trigon inlay²

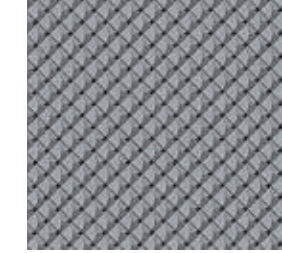

Dark Brown Walnut Wood inlay²

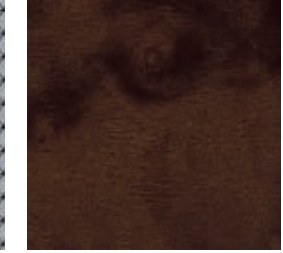

Fine Grain Ash Natural Brown Wood inlay²

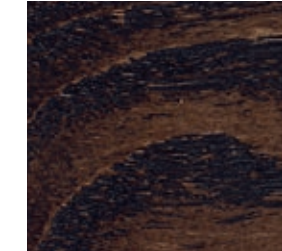

Layered Oak Wood inlay²



¹ Tires are supplied and warranted by their manufacturer. High-performance tires are designed for optimum performance and handling in warm climates. They are not suitable for cold, snowy or icy weather conditions. If you drive under those circumstances, you should equip your vehicle with all-season or winter tires, which offer better traction under those conditions. We suggest you use the recommended winter or all-season tire specified for your car or its equivalent. These high-performance tires also have a lower aspect ratio that aids performance and handling; however, in order to avoid tire, rim or vehicle damage, it is important that the inflation pressure is regularly checked and maintained at optimum levels. Please also remember in making your selection that, while these tires deliver responsive handling, they may ride less comfortably and make more noise than other choices. Finally, these tires may wear more quickly than other choices. ² Decorative inlay options will vary based on model and interior color combination. See your dealer for details.

Technical Specifications

Engineering | Performance

	allroad®
Engine type	Four-cylinder
Engine block/Cylinder head	Cast-iron/Aluminum-alloy
Displacement (cc)/Bore and stroke (mm)	1,984/82.5 x 92.8
Horsepower (@ rpm)	220 @ 4,450–6,000
Torque (lb-ft @ rpm)	258 @ 1,500–4,300
Compression ratio	9.6:1
Valvetrain	16-valve DOHC with valvelift system
Induction/Fuel injection	Turbocharged/TFSI®
Acceleration (0–60 mph)	6.4 seconds
Top track speed ¹	130 mph

Transmission | Drivetrain

Eight-speed Tiptronic® automatic transmission with Audi quattro® all-wheel drive (Gear ratios: 1st: 4.714, 2nd: 3.143, 3rd: 2.106, 4th: 1.667, 5th: 1.285, 6th: 1.000, 7th: 0.839, 8th: 0.667, Reverse: 3.317, Final drive: 3.076)	■
---	---

Body | Suspension | Chassis

Fully galvanized steel unibody with aluminum hood and multistep anti-corrosion protection	■
Five-link front suspension	■
Trapezoidal-link rear suspension	■
Ventilated front disc/Solid rear disc brakes (in)	12.6/11.8
Electromechanical power steering system	■
Dynamic steering (Prestige)	Available
Steering ratio	15.9:1
Turning diameter, curb-to-curb (ft)	37.7

Exterior measurements

	allroad®
Wheelbase (in)	110.4
Length (in)	185.9
Height (in)	58.0
Overall width with mirrors (in)	79.0
Overall width without mirrors (in)	72.5
Track front/rear (in)	62.3/62.0
Ground clearance, loaded (in)	7.1
Curb weight	3,891
Drag coefficient (Cw)	.36

Interior measurements

Head room with sunroof (in, front/rear)	38.5/38.2
Head room with sunshade (in, front/rear)	36.8/37.4
Leg room (in, front/rear)	41.3/35.2
Shoulder room (in, front/rear)	55.5/54.3
Cargo volume (cu ft, rear seatbacks up/folded)	27.6/50.5
Seating capacity	5

EPA mileage estimates | Capacities | Emissions

Tiptronic® automatic transmission (city/highway/combined) ²	NA
Engine oil (qt)	4.9
Fuel (gal)	16.1
Recommended fuel	Premium
Emissions rating	ULEV II

■ Standard — Not applicable **NA** Information not available at time of printing

¹ Top track speed is electronically limited in the U.S. Obey all speed and traffic laws. ² EPA estimates not available at time of printing. See www.fueleconomy.gov for updated information. Your mileage will vary.

Featured Content

Safety Security	Premium	Premium plus	Prestige
Driver and front passenger dual-stage airbags, front thorax side airbags and Sideguard® head curtain airbags ¹	■	■	■
Rear-passenger thorax side airbags ¹	Available	Available	Available
Front-passenger occupant detection for airbags ¹	■	■	■
Safety belt reminder for driver and front passenger	■	■	■
Lower Anchors and Tethers for CHildren (LATCH) in rear seats	■	■	■
Power central locking system with safety unlock feature if airbags deploy	■	■	■
Electronic Stability Control (ESC) with Off-road mode and traction control (ASR)	■	■	■
Anti-lock Brake System (ABS) with Electronic Brake-pressure Distribution (EBD) and brake assist	■	■	■
Tire-pressure monitoring system	■	■	■
Electromechanical parking brake	■	■	■
Anti-theft alarm system with immobilizer	■	■	■

Exterior	Premium	Premium plus	Prestige
Audi Singleframe® grille	■	■	■
Halogen headlights with daytime running lights	■	—	—
Xenon plus headlights with LED daytime running light technology	Available	■	—
Adaptive xenon plus headlights with LED daytime running light technology	—	—	■
Headlight washing system	■	■	■
Automatic headlights	■	■	■
Front and rear fog lights	■	■	■
LED taillight technology	Available	■	■
Power-adjustable heated exterior side mirrors	■	—	—
Power-adjustable, power-folding, auto-dimming, heated exterior side mirrors with memory	—	■	■
LED turn indicator light technology integrated into the exterior side mirrors	■	■	■
Heated windshield washer nozzles	■	■	■
Aluminum roof rails	■	■	■
Aluminum trim around exterior windows	■	■	■
Power tailgate open/close	—	■	■
Dual exhaust outlets	■	■	■
Audi allroad® exterior appearance with contrasting cladding, stainless steel underbody protection and side sill inserts	■	■	■

■ Standard — Not applicable

Exterior (continued)	Premium	Premium plus	Prestige
Audi allroad® exterior appearance with full-paint finish (limited exterior colors)	Available	Available	Available

Interior	Premium	Premium plus	Prestige
Automatic climate control	■	—	—
Three-zone automatic climate control	—	■	■
Four-spoke multifunction steering wheel	■	■	■
Three-spoke multifunction sport steering wheel with shift paddles	—	Available	Available
Tilt and telescopic manually adjustable steering column	■	■	■
Auto-dimming interior rear view mirror with digital compass	—	■	■
Illuminated locking glove box	■	■	■
Leather-wrapped shift knob	■	■	■
Folding and sliding front center armrest with height adjustment	■	■	■
Eight beverage holders (four cup and four bottle)	■	■	■
Decorative interior inlays (see Decorative Inlays page for more detail)	■	■	■
Aluminum door sill inlays	■	■	■
Front and rear footwell LED lighting technology	■	■	■
Front and rear floor mats	■	■	■
Ambient LED interior lighting technology	■	■	■
Black cloth headliner (with Chestnut Brown leather)	Available	Available	Available
Dual front sun visors with lighted vanity mirrors	■	■	■
Power windows with one-touch up/down operation and pinch protection	■	■	■
Manual rear-side window sunshades	—	—	■
Panoramic sunroof	■	■	■

Seating	Premium	Premium plus	Prestige
Leather seating surfaces (see Interior Colors page for more detail)	■	■	■
Eight-way power front seats and four-way power lumbar adjustment for driver	■	■	■
Twelve-way power front sport seats, including four-way power lumbar adjustment	—	Available	Available
Driver seat memory	—	■	■
Heated front seats	Available	■	■
Split folding 60/40 rear seatbacks	■	■	■

¹ Airbags are supplemental restraints only and will not deploy under all crash circumstances. Always use safety belts and seat children only in the rear, using restraint systems appropriate for their size and age.

Featured Content

Infotainment Technology	Premium	Premium plus	Prestige
Audi MMI® Navigation plus with voice control system ¹	—	Available	■
Audi connect® with six-month trial subscription ²	—	Available	■
Driver information system	■	■	—
Color driver information system	—	Available	■
Audi concert radio with ten speakers and single CD player with MP3 playback capability	■	■	—
Bang & Olufsen® Sound System with 14 speakers and 505 watts	—	Available	■
HD Radio™ Technology	—	Available	■
SiriusXM® Satellite Radio with 90-day trial subscription ³	■	■	■
SiriusXM® Traffic with four-year subscription ³	—	Available	■
SD card slot with 32GB operating capacity (dual slots if equipped with Audi MMI® Navigation plus)	■	■	■
Audi music interface with iPod® integration	■	■	■
BLUETOOTH® streaming audio ⁴	—	Available	■
BLUETOOTH® wireless technology preparation for mobile phone ⁴	■	■	■
Four 12-volt power outlets	■	■	■
Garage door opener (HomeLink®)	■	■	■
Audi advanced key—keyless start, stop and entry ⁵	—	■	■
Cruise control with coast, resume and accelerate features	■	■	■
Audi adaptive cruise control	—	—	Available
Audi side assist	—	Available ⁶	■
Audi drive select	—	—	Available
Parking system plus with rear view camera	—	Available	■
Rain/light sensor for automatic windshield wipers and headlights	■	■	■

■ Standard — Not applicable

¹ Audi MMI® Navigation plus depends on signals from the worldwide Global Positioning Satellite network. The vehicle's electrical system and existing wireless and satellite technologies must be available and operating properly for the system to function. The system is designed to provide you with suggested routes in locating addresses, destinations and other points of interest. Changes in street names, construction zones, traffic flow, points of interest and other road system changes are beyond the control of Audi of America, Inc. Complete detailed mapping of lanes, roads, streets, toll roads, highways, etc., is not possible, therefore you may encounter discrepancies between the mapping and your actual location. Please rely on your individual judgment in determining whether or not to follow a suggested Audi MMI® Navigation plus route. For mapping updates please see your Audi dealer or call 1-800-FOR-AUDI for details. ² See the Audi connect® page for important information about Audi connect®. ³ SiriusXM® Satellite Radio and Traffic subscriptions sold separately or as a package after trial expires. SiriusXM® Traffic service available in select markets. Subscriptions are governed by SiriusXM® Customer Agreement (see www.siriusxm.com) and are continuous until you call SiriusXM® to cancel. SiriusXM® U.S. Satellite Service available only to those 18 and older in the 48 contiguous U.S.A., D.C. and Puerto Rico (with coverage limitations). ⁴ Requires compatible phone. ⁵ Some Audi models are equipped with a keyless ignition feature. The details as to how the system works can vary, and Audi owners should consult their owner's literature or an authorized Audi dealer if they have further questions about the operation of this feature. Please note that Audi warns against leaving the vehicle unattended with the engine running, particularly in enclosed spaces. ⁶ Delayed availability. ⁷ See dealer for details. ⁸ All roof-rack system attachments require the base carrier bars. All attachments sold separately. ⁹ Recreational equipment and sporting equipment not included.

Accessories

Add a new point of view, a dash of distinction and the ultimate in self-expression with Audi Genuine Accessories. Whether you load the cargo carrier with climbing gear or add a set of sporty new wheels, we've got the accessories that will help enhance every facet of your lifestyle. Designed for seamless compatibility with your Audi, all pieces are backed by your vehicle's 4-year/50,000-mile limited warranty or the accessory's 12-month/12,000-mile limited warranty, whichever extends longer from the accessory purchase date.⁷ If you're looking to personalize or protect, Audi offers an intelligent solution.



Splash guards

Help protect the vehicle's finish with custom-fit splash guards. Made of crack-resistant rubber. Available in sets of two for front or rear.

Fork-mount bike rack

Made of anodized aluminum, this rack features a quick-clamping device that can be secured with the included lock.^{8,9}



Ski and snowboard rack

Push-button, keyed locks open and close easily. Rubber-cushioned aluminum bars hold securely. Standard attachment (shown) holds two sets of skis or two snowboards. Deluxe attachment holds up to three sets of skis or four snowboards.^{8,9}

Small cargo carrier

Extra carrying capacity (13 cu ft) comes in a smart size: 55" long, 35" wide, 14" high.⁸



Premium textile floor mats

These skid-resistant, precision-fit mats are made of long-life fabric to help protect the vehicle's interior from the elements. Mats are black with silver piping and available in a set of four.

All-weather cargo mat

Custom fit for the Audi allroad®. Textured material helps control load shifting. Raised lip helps contain spills and protect cargo-area carpeting from stains.

Other accessories not shown →

Audi Genuine Sport and Design Accessories

Your Audi vehicle features a bold, aggressive stance and strong, stunning lines. Enhance it by adding Audi Genuine Sport and Design Accessories. All are carefully scrutinized in the design and development process. So while they're striking in appearance, they've also passed rigorous quality assessments, including corrosion testing. If you're looking for a bolder appearance or a finishing touch, there is a solution designed by Audi that makes every mile more enjoyable—and more yours.

Audi Genuine Alloy Wheels

Strike the perfect balance between breathtaking design and awe-inspiring performance with Audi Genuine Alloy Wheels. Audi experts have meticulously designed these wheels especially for each Audi model. They're engineered to the highest standards and endure rigorous testing to help ensure long-term quality. Experience eye-catching style that is yours and yours alone. Nothing enhances the bold, dynamic look of your Audi vehicle faster.



2014 | allroad®

Audi of America
Audiusa.com
Facebook.com/Audi

Note: A word about this brochure. Audi of America, Inc., believes the specifications in this brochure to be correct at the time of printing. However, specifications, standard equipment, options, fabrics, and colors are subject to change without notice. Some equipment may be unavailable when your vehicle is built. Please ask your dealer for advice concerning current availability of standard and optional equipment, and your dealer will verify that your vehicle will include the equipment you ordered. Vehicles in this brochure are shown with optional equipment. See your dealer for complete details on the Audi New Vehicle Limited Warranty, twelve-year limited warranty against corrosion perforation, and Audi 24/7 Roadside Assistance. (Roadside assistance coverage provided by Road America in the U.S. Certain conditions apply; see your dealer for details.) Tires supplied by various manufacturers. "Audi," all model names, "allroad," "Audi connect," "Audi Sport," "Audi ultra," "FSI," "MMI," "quattro," "Sideguard," "Singleframe" and the Singleframe grille design, "TFSI," "Truth in Engineering," and the four rings logo are registered trademarks of AUDI AG. "Bang & Olufsen" is a registered trademark of Bang & Olufsen. The BLUETOOTH word mark and logos are owned by the Bluetooth SIG, Inc., and any use of such marks by AUDI AG is under license. "BOSE" is a registered trademark of the BOSE Corporation. "Google," "Google Earth" and "Google Voice" are trademarks of Google Inc. "HD Radio" and the HD Radio logo are proprietary trademarks of iBiquity Digital Corporation. "HomeLink" is a registered trademark of Johnson Controls Technology Company. "iPod" is a registered trademark of Apple Inc. "SiriusXM" and all related marks and logos are trademarks of Sirius XM Radio Inc. and its subsidiaries. "TDI" is a registered trademark of Volkswagen AG. "Tiptronic" is a registered trademark of Dr. Ing h.c. F. Porsche AG. "Wi-Fi" is a trademark of the Wi-Fi Alliance. All other trademarks are the property of their respective owners. Some European models shown.