



A6 S6



**What happens when
progress is mandate.**

The Audi A6 is bristling with technological innovations such as the powerful new 300 hp, 3.0 liter TFSI® supercharged V6 and the dynamic integration of weight-saving aluminum in the hood and fenders. With its sculpted contours and attention to detail, the A6 embodies a design aesthetic that perfectly fuses poise, luxury and performance.





Where luxury and innovation converge.

The seamless integration of technology and luxury sets the Audi A6 apart. Aside from twelve-way power heated leather seats and wood inlays, the Audi A6 cabin also offers the latest technology by way of the advanced 3rd generation Audi MMI®. True to its name, the Multi Media Interface allows storage of up to 2000 tracks of music, DVD playback on a large, 7" display screen, available 3D navigation, voice control and an intuitive joystick for effortless operation.

Power is never in short supply.

Audi innovation is more than alive, it is flourishing. Take the exceptionally potent 300 hp 3.0 liter TFSI® V6 for example. Thanks to a powerful combination of FSI® direct injection and supercharger technology, the engine produces a forceful 310 lb-ft. of torque from 2500 to 5100 rpm. Along with an increase of power, these innovations elevate efficiency to new levels, as proven by an economical 26 MPG* on the highway. The A6 also offers the increased horsepower of the re-engineered 265 hp 3.2 liter FSI® V6 or the 350 hp 4.2 liter FSI® V8. All of these engines showcase Audi FSI® direct injection technology and variable valve timing – making superlative power, performance and efficiency standard on every A6.



* EPA fuel economy estimates for 3.0T supercharged V6 city/highway: 18/26 MPG. Your mileage will vary.



**Do not let the four doors fool you.
It drives like it seats one.**

With the 40:60 rear bias of quattro® all-wheel drive, the A6 delivers more than confidence in inclement weather – it delivers true sportscar-like handling on dry roads too. Care for an even sportier experience? The available Sport Package includes a stiffer, more responsive sport suspension and standard 18" wheels with all-season tires or optional 19" wheels with summer performance tires*. Inside, the Sport Package includes a race-inspired, three-spoke, multifunction steering wheel with shift paddles.

Prone to double takes.

The Audi A6 easily stands out in a crowd. It offers forward-looking design like the assertive singleframe® grille, radiant LED taillights and available daytime running lights, which cap off an ideal expression of progress. Turn up the versatility quotient and you will find the desirable A6 Avant, uniquely matched for the driver who needs more space from a sports sedan.





**Audi safety is more than reactive,
it's proactive.**

Even when you are not thinking about safety, the Audi A6 is. Prevention is always the best safety feature and that is why the Audi A6 includes ESP® [Electronic Stabilization Program]. The system employs a number of safety features for greater control in emergency conditions and handling situations close to the limit. In addition to helping monitor blind spots, the available Audi side assist also adds a measure of prevention by warning the driver of rapidly approaching vehicles from the rear and side. On top of that, there are an available eight airbags* throughout the cabin, as well as strengthened door beams to prevent cockpit intrusions in the event of an accident.

* Airbags are supplemental restraints only and do not deploy in all crash circumstances. Always use safety belts and seat children in the rear, using restraint systems appropriate for their size and age. Images do not depict what will happen in an accident. All bags will not inflate in real world accidents and if multiple bags do deploy, they will be in various stages of inflating/deflating and will never all be inflated at the same time.



**For those who have high expectations:
Prepare to have them exceeded.**

In the Audi A6 cabin, every detail is pored over to deliver optimum comfort and performance. With a driver-oriented cockpit, the A6 puts you in complete control. The multifunction, leather-wrapped steering wheel allows the driver to navigate many of the entertainment and information systems without having to move their hands from the wheel. Bring up your Bluetooth[®]-enabled phone, enter an address into the available 3rd generation MMI[®] navigation system or just summon the radio – it can all be done via the integrated voice control of the multifunction steering wheel. Additionally, the ease of keyless entry and push-button ignition is available with the convenient Audi advanced key.



**The notion of what a car can be
is now forever changed.**

With pronounced, sporty touches, the Audi S6 ensures there is no mistaking it for anything other than a true, performance sports sedan. The aggressive quad exhaust tips, which hint to the V10 power beneath the hood, unique diffuser and purposeful 19" alloy wheels create a commanding presence. Yet another example of sophisticated good looks backed up by world-class performance.

Performance starts on the inside.

The interior of the Audi S6 is replete with performance features. For example, the driver-oriented cockpit includes a special three-spoke, multifunction steering wheel and a specially designed Audi S6 instrument cluster that comes to life with the roar of the powerful V10 engine. While in motion, the hand-crafted Silk Nappa leather sport seats are soft yet specially sculpted to offer a high level of support in the most demanding driving situations. But that's just the beginning. The Audi S6 also features a BOSE® sound system, optional Carbon Fiber inlays, 3D navigation and numerous 3rd generation MMI® entertainment functions, including DVD playback, an SD® card interface to load music to the hard drive and Audi music interface to control your iPod®.



We prefer being ahead of the curve.

Advanced technology is as much a part of Audi DNA as performance. Bring them together and you have something truly remarkable. Take the 5.2 liter FSI® V10 engine for instance. In building the powerplant, engineers fought to shave every gram of weight possible, reinforcing the philosophy that lightweight design allows for greater all-around performance. One step on the throttle and the instantaneous response and exceptional low-end torque more than back up a commitment to inspired engineering. But that is only the beginning. With 435 hp and 398 lb.-ft. of torque capable of launching you from 0 to 60 MPH in 5.1 seconds, this is power that takes engineering and the driving experience to an entirely new place.





Power, with the brakes to back it up.

With so much available power, the S6 has brakes to match. Braking begins with high-performance brake pads that help maximize performance by minimizing fade. Additionally, with large 15.2" ventilated front brake rotors and six-piston painted calipers, cooled by air channeled through the lower grille, the S6 stops with the utmost confidence. Not what you would expect from a four-door sedan, unless it is the Audi S6.

**If its power does not give it away,
its looks certainly will.**

The Audi S6 has the power to stir your soul and turn heads. It harnesses the latest technology and design by employing distinctive, long-life LED daytime running lights as well as adaptive Audi xenon plus headlights. The unmistakable singleframe® front grille offers a nod to its history of motorsport dominance. And it has the muscular stance of a car designed to assert its performance potential. The Audi S6 looks the part and it most definitely plays the part.





- 1 **LED taillights** | LED lights are superior to conventional bulbs with their activation speed and long service life. They can last an entire vehicle lifetime, consume up to 50 percent less energy and take up less space.
- 2 **MMI[®] advanced** | The Audi A6 comes equipped with the latest generation of advanced MMI[®]. The MMI[®] system is comprised of a color, high-resolution, 7" display screen, control knob with joystick and buttons in the center console to operate climate control, central locking, instrument cluster, vehicle diagnostics, cellular phone, CD and radio functions.
- 3 **Leather shift knob** | The quality and craftsmanship of leather and aluminum accents enhance the overall interior excellence of the A6.
- 4 **Sunroof** | Standard on all A6 models, the sunroof provides passengers with a light and airy driving experience.
- + **Dark Brown Walnut wood inlay** | The genuine wood decorative inlays in the dash, center console and door panels add a refined touch of luxury to the A6.
- + **Leather-wrapped, four-spoke, multifunction steering wheel** | The leather-wrapped, four-spoke design has a refined look and feel. The multifunction steering wheel provides easy access to audio volume, radio stations, CD track selection, telephone dialing and the voice control system.
- + **Audi music interface with iPod[®] integration** | The Audi music interface offers intelligent integration with the iPod[®]. Any iPod[®] Generation 4 and higher (iPod[®], iPod[®] nano, iPod[®] photo) may be connected through the glove box, and full iPod[®] controls are available through the MMI[®] screen.
- + **Bluetooth[®]** | The Bluetooth[®] hands-free phone interface allows the pairing of a Bluetooth[®]-enabled mobile phone with the vehicle, and includes access to the phonebook within the driver information display of the instrument panel.
- + **Twelve-way power seats** | The twelve-way power seats allow the driver and passenger to electronically adjust the seat's forward/backward position, height, lumbar support and angle of seat cushion and seatback. In addition, the 3.0T comes equipped with a multilevel seat-heating system designed to heat the entire surface of the seat.
- + **SIRIUS[®] Satellite Radio** | Enjoy commercial-free music, talk and more with a subscription to the SIRIUS[®] Satellite Radio network.

Features listed are standard on the Premium model unless otherwise noted.

+ FEATURE NOT SHOWN

5 Aluminum doorsill and window trim | The aluminum doorsill and window trim complement the stylish lines of the A6, adding a touch of sporty elegance to the vehicle.

6 Audi xenon plus headlights with LED daytime running lights | Audi xenon plus headlights produce about twice as much light as comparable halogen headlights. LED daytime running lights consume less energy than conventional daytime running lights and add a distinct elegance to the A6.

7 18" five-Y-spoke wheels with 245/40 all-season tires | The 18" five-Y-spoke wheel comes standard with the Premium Plus and offers a stylish and refined look to the A6 exterior.

8 Audi MMI® Navigation plus | The Audi MMI® Navigation plus features a 7", full-color LCD screen and MMI® control logic. The Audi A6 comes equipped with the latest generation of MMI®, powered by a 40-GB hard drive and an NVIDIA® processor to enhance graphics. This generation of MMI® offers 3D topography, including the buildings in many cities. It also features real-time traffic reporting and navigation information given as audible route guidance prompts and turn arrows via the color driver information system. This includes voice control to operate the navigation, radio and hands-free telephone functions.

+ Auto-dimming interior mirror with compass and heated, auto-dimming exterior mirrors with memory | The rearview mirror with compass and exterior mirrors recognize bright lights behind the car and darken the mirror glass automatically.

+ Driver's seat memory | The driver's seat memory remembers the occupant's seat position and recalls it with the push of a button for added convenience.

Features listed are standard on the Premium Plus model unless otherwise noted.

+ FEATURE NOT SHOWN



A6 3.0T Prestige



1



2



3

A6 3.0T Prestige

1 Leather-wrapped, four-spoke, multifunction steering wheel with shift paddles | The leather-wrapped, four-spoke design has a refined look and feel. The multifunction steering wheel provides easy access to audio volume, radio stations, CD track selection, navigation voice prompts, telephone dialing and the voice control system. Shift paddles allow for quick and sporty gear changes.

2 BOSE® 5.1 Surround Sound | A total of 13 high-performance speakers are placed throughout the cabin to create a rich and dynamic stereo experience. Speakers include a 3.25" centerfill speaker in the instrument panel, two 3.25" high-range speakers on each front door and two 5.25" Richbass® woofers housed in a custom-engineered enclosure on each front door. In addition, the BOSE® exclusive AudioPilot® noise compensation technology adjusts the volume in response to unwanted road noise, enhancing the listening experience.

3 Audi advanced key | With Audi advanced key, the car can be unlocked and started without removing the key from a pocket or purse. The steering can be released and the ignition turned on electronically, all without inserting the key into the ignition.

+ 18" ten-spoke wheels with 245/40 all-season tires | These impeccably designed wheels provide a touch of sporty elegance to the classically crafted package. The all-season tires help provide a safe and comfortable ride in a variety of weather conditions.

+ Audi xenon plus adaptive headlights with LED daytime running lights | Audi xenon plus headlights produce about twice as much light as comparable halogen headlights. Utilizing input from the steering and speed of the vehicle, adaptive headlights pivot up to 15 degrees, lighting up corners and curves more effectively. LED daytime running lights consume less energy than conventional daytime running lights and add a distinct elegance to the A6.

+ Power adjustable steering column | The power adjustable steering column is an added touch of luxury to the A6, ensuring maximum driving comfort.

+ Rearview camera | The rearview camera aid helps the driver see objects behind the vehicle when backing up. It helps make parking more convenient.

Features listed are standard on the Prestige model unless otherwise noted.

+ FEATURE NOT SHOWN

4 S line bumpers | Exclusive to the A6 4.2, the unique S line bumpers accentuate the already sporty and powerful exterior of the A6, differentiating it from other models.

5 18" ten-spoke wheels with 245/40 all-season tires | Standard on the A6 4.2, the impeccably designed wheels provide a touch of sporty elegance to the A6. The all-season tires help provide a safe and comfortable ride in a variety of weather conditions.

6 Rearview camera | The rearview camera aid helps the driver see objects behind the vehicle when backing up. It helps make parking more convenient.

Audi xenon plus adaptive headlights with LED daytime running lights | Audi xenon plus headlights produce about twice as much light as comparable halogen headlights. Utilizing input from the steering and speed of the vehicle, adaptive headlights pivot up to 15 degrees, lighting up corners and curves more effectively. LED daytime running lights consume less energy than conventional daytime running lights and add a distinct elegance to the A6.

Audi MMI® Navigation plus | The Audi MMI® Navigation plus features a 7", full-color LCD screen and MMI® control logic. The Audi A6 comes equipped with the latest generation of MMI®, powered by a 40-GB hard drive and an NVIDIA® processor to enhance graphics. This generation of MMI® offers 3D topography, including the buildings in many cities. It also features real-time traffic reporting and navigation information given as audible route guidance prompts and turn arrows via the color driver information system. This includes Audi parking system advanced with rearview camera, a color driver information system and voice control to operate the navigation, radio and hands-free telephone functions.

Driver's seat memory | The driver's seat memory remembers the occupant's seat position and recalls it by the push of a button for added comfort.

Auto-dimming interior mirror with compass and heated, auto-dimming exterior mirrors with memory | The rearview mirror with compass and exterior mirrors recognize bright lights behind the car and darken the mirror glass automatically.

BOSE® 5.1 Surround Sound | A total of 13 high-performance speakers are placed throughout the cabin to create a rich and dynamic stereo experience. Speakers include a 3.25" centerfill speaker in the instrument panel, two 3.25" high-range speakers on each front door and two 5.25" Richbass® woofers housed in a custom-engineered enclosure on each front door. In addition, the BOSE® exclusive AudioPilot® noise compensation technology adjusts the volume in response to unwanted road noise, enhancing the listening experience.

Features listed are standard on the Audi A6 4.2 unless otherwise noted.

+ FEATURE NOT SHOWN



A6 Packages



A6 Cold Weather Package

1 Heated rear seats | The multilevel seat heating system is designed to heat the entire surface of the seat; warming is initiated with a convenient button. [Heated front seats are also included in the Cold Weather Package on the 3.2]

+ Heated, four-spoke, multifunction steering wheel | The heated, four-spoke, multifunction steering wheel provides easy access to volume control, radio station and CD track selection, navigation voice prompts and telephone dialing.

A6 Sport Package

2 Sport steering wheel with shift paddles | The three-spoke, leather-wrapped, multifunction steering wheel includes shift paddles and has a sporty look and feel. It provides easy access to audio volume control, radio station and CD track selection, navigation voice prompts and telephone dialing while offering an enhanced grip for a variety of driving conditions.

3 18" five-spoke wheels with 245/40 all-season tires | The refined simplicity of this classic five-spoke wheel complements the fluid lines of the Audi A6. The all-season tires help provide a safe and comfortable ride in a variety of weather conditions.

4 19" five-tri-spoke wheels with 255/35 summer performance tires* | The 19" five-tri-spoke wheel option is impressive in its stance and design. The wheels come equipped with summer performance tires, which provide improved driving dynamics and superior handling and performance. [Premium Plus and Prestige only]

+ Sport suspension | For those who plan to drive in a more sporty fashion, the Sport Package includes a firmer, lower suspension. The suspension has been specially sport-tuned to perform without sacrificing passenger comfort.

* See page 34 for important safety information regarding summer performance tires.

+ FEATURE NOT SHOWN

A6 Options

- * **Rear side airbags*** | The A6 offers rear side airbags, which can help reduce the risk of severe injuries in certain collisions.
- * **Audi side assist** | Audi side assist helps monitor blind spots, as well as fast-approaching vehicles at a range of about 150 ft. to the rear of the car. If Audi side assist identifies another vehicle when the driver signals to change lanes, it informs the driver using an LED light in the exterior mirror.

* Airbags are supplemental restraints only and do not deploy in all crash circumstances. Always use safety belts and seat children in the rear, using restraint systems appropriate for their size and age.

* FEATURE NOT SHOWN



A6 Options



1



2



3

1 S6 sport seats | In addition to greater lateral support, the specifically contoured S6 sport seats deliver a sporty and secure feel. Covered in Silk Nappa leather, the heated seats also feature four-way lumbar control.

2 S6 aluminum doorsills | The stylish aluminum trim accents the overall interior excellence of the S6.

3 S6 sport steering wheel | S6-specific three-spoke, multifunction, leather-wrapped steering wheel with aluminum shift paddles, S6 badge and contrast stitching adds a performance look and feel to the already impressive interior.

+ **Leather shift knob** | The superior quality leather, impeccable craftsmanship and aluminum accents add to the elegant and dynamic driving experience.

+ **Sport suspension** | The suspension has been specially tuned to enhance performance without sacrificing passenger comfort.

+ **Audi advanced key** | With Audi advanced key, the car can be unlocked and started without removing the key from a pocket or purse. The steering can be released and the ignition turned on electronically, all without inserting the key in the ignition.

+ **Heated front and rear seats** | The multilevel seat heating system is designed to heat the entire surface of the seat.

+ **Audi xenon plus adaptive headlights with LED daytime running lights** | Audi xenon plus headlights produce about twice as much light as comparable halogen headlights. Utilizing input from the steering and speed of the vehicle, adaptive headlights pivot up to 15 degrees, lighting up curves more effectively. LED daytime running lights consume less energy than conventional daytime running lights and add a distinct elegance to the S6.

Features listed are standard on the Audi S6 unless otherwise noted.

+ FEATURE NOT SHOWN

S6

4 S6 exterior | The S6 includes a number of distinguishing exterior features. Among them, the unique S design front bumper with LED daytime running lights, rear bumper with diffuser to complement the quad exhaust tailpipes, unique lower door blades and Aluminum Optic mirrors with integrated LED turn signals.

5 19" five-parallel-spoke S design wheels with 265/35 summer performance tires* | These impressive wheels are standard on the S6 and are complemented by summer performance tires which provide the driver with superior handling.

6 Gray Birch wood inlay | The Gray Birch wood inlay adds a touch of elegance to the S6 interior.

+ BOSE® 5.1 Surround Sound | A total of 13 high-performance speakers are placed throughout the cabin to create a rich and dynamic stereo experience. Speakers include a 3.25" centerfill speaker in the instrument panel, two 3.25" high-range speakers on each front door and two 5.25" Richbass® woofers housed in a custom-engineered enclosure on each front door. In addition, the BOSE® exclusive AudioPilot® noise compensation technology adjusts the volume in response to unwanted road noise, enhancing the listening experience.

+ SIRIUS® Satellite Radio | Enjoy commercial-free music, talk and more with a subscription to the SIRIUS® Satellite Radio network.

+ Bluetooth® | The Bluetooth® hands-free phone interface allows the pairing of a Bluetooth®-enabled mobile phone with the vehicle, and includes access to the phonebook within the driver information display of the instrument panel.

+ Audi MMI® Navigation plus | The Audi MMI® Navigation plus features a 7", full-color LCD screen and MMI® control logic. The Audi S6 comes equipped with the latest generation of MMI®, powered by a 40-GB hard drive and an NVIDIA® processor to enhance graphics. This generation of MMI® offers 3D topography, including the buildings in many cities. It also features real-time traffic reporting and navigation information given as audible route guidance prompts and turn arrows via the color driver information system. This includes Audi parking system advanced with rearview camera, a color driver information system and voice control to operate the navigation, radio and hands-free telephone functions.

Features listed are standard on the Audi S6 unless otherwise noted.

*See page 34 for important safety information regarding summer performance tires.

+ FEATURE NOT SHOWN

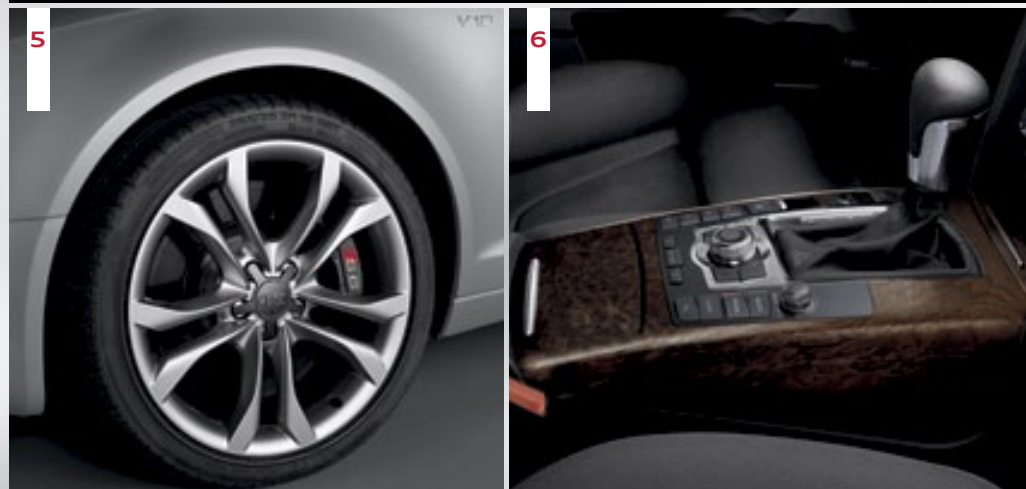

S6 Options



1



2



3

S6 Options

- 1 Milano leather** | The appointment of high-quality Milano leather on the optional seats of the S6 adds to the exclusive and elegant S6 driving experience.
- 2 Carbon Fiber inlay** | Exclusive only to Audi S series vehicles, the sophisticated Carbon Fiber inlay accents the overall interior excellence of the S6 with a performance feel.
- 3 18" seven-double-spoke alloy wheels with 255/40 summer performance tires*** | The eye-catching seven-double-spoke wheels are optional and come equipped with summer performance tires.
- + Rear side airbags*** | The S6 offers rear side airbags, which can help reduce the risk of severe injuries in certain collisions.
- + Audi side assist** | Audi side assist helps monitor blind spots, as well as fast-approaching vehicles at a range of about 150 ft. to the rear of the car. If Audi side assist identifies another vehicle when the driver signals to change lanes, it informs the driver using an LED light in the exterior mirror.

* See page 34 for important safety information regarding summer performance tires.

* Airbags are supplemental restraints only and do not deploy in all crash circumstances. Always use safety belts and seat children in the rear, using restraint systems appropriate for their size and age.

+ FEATURE NOT SHOWN

4 Front valance | This exclusively designed exterior component creates a dynamic, lowered appearance with a front valance and blade. [A6 only]

5 Compact roof box | The compact roof box offers a large, 16.95 cubic foot capacity. Size: 81" long, 30" wide. [Must be used in combination with the base carrier bars, which are sold separately]

6 19" Calera wheels | These alloy wheels grab attention with their distinctive split spoke design. All of our wheels are specially engineered to meet the strict tolerances of our Audi original equipment wheels. [A6 only]

7 Splash guards | Help protect your exterior finish with custom-fit front and rear splash guards. Made of long-life, crack-resistant rubber. Available in sets of two for the front and the rear. [A6 only]

8 Rear valance | The specially designed rear valance styling component adds an aggressive edge to the A6. [A6 only]

+ Upright Barracuda® bicycle holder | This bike holder fits 20-80 mm bike frames and is easy to use. It features a molded front wheel well that allows the bike to stand on its own as you easily secure the bike. Lock included. [Must be used in combination with the base carrier bars, which are sold separately]

+ Luggage basket | Mount this attachment in the upright position and it forms a basket to hold luggage. Mount it downward and it creates a flat surface for transporting loads. Supports up to 165 lb. [Must be used in combination with the base carrier bars, which are sold separately]

+ Storage cover | Help protect your Audi from the elements with this lightweight, easy-to-use cover. Made of Stormshield® material custom cut for your Audi. Cover has a plastic window so the rear license plate is visible. Includes a storage bag.

+ Rubber floor mats | These trim-profile, embossed rubber mats help extend the life of your carpet. Available in Black in sets of two for the front and the rear.

+ Rubber cargo mat | Custom fit for your Audi. Textured plastic material controls load shifting. The raised lip contains spills and helps protect cargo area carpeting from stains. Easily cleaned with mild soap and water.

See your local Audi dealer for the complete selection of Genuine Audi Accessories.

+ FEATURE NOT SHOWN



A6 Wheel Options

1



4



2



5



3



A6 Wheel Options

- 17" five-spoke wheels with 245/45 all-season tires** | These wheels give the A6 a sporty look and feel. The all-season tires help provide a safe and comfortable ride in a variety of weather conditions. [A6 Premium]
- 18" five-Y-spoke wheels with 245/40 all-season tires** | The 18" five-Y-spoke wheels offer a stylish and refined look to the A6 exterior. [A6 Premium Plus]
- 18" ten-spoke wheels with 245/40 all-season tires** | This impeccably designed wheel provides a touch of sporty elegance to the A6. [A6 Prestige]
- 18" five-spoke design wheels with 245/40 all-season tires** | The refined simplicity of this sporty five-spoke wheel complements the fluid lines of the A6. [Sport Package only]
- 19" five-tri-spoke wheels with 255/35 summer performance tires*** | The 19" five-tri-spoke wheel option is impressive in its stance and design. The wheels come equipped with summer performance tires, which provide improved driving dynamics and superior handling and performance. [Optional on Sport Package with Premium Plus and Prestige only]

* Summer performance tires are designed for optimum performance and handling in warm climates. They are not suitable for cold, snowy or icy weather conditions. If you drive under those circumstances, you should equip your vehicle with all-season or winter tires, which offer better traction under those conditions. We suggest you use the recommended winter or all-season tires specified for your car or their equivalent. These summer performance tires also have a lower aspect ratio that aids performance and handling; however, in order to avoid tire, rim or vehicle damage, it is important that the inflation pressure is regularly checked and maintained at recommended levels. Serious wheel and tire damage may occur if the vehicle is operated on rough or damaged road surfaces, or upon encountering road debris or obstacles. Please also remember in making your selection that, while these tires deliver responsive handling, they may ride less comfortably and make more noise than other choices. Finally, these tires may wear more quickly than other choices. For more information on all of these topics, please consult the owner's manual, your local dealer or call 1-800-FOR-AUDI.

6 19" five-parallel-spoke S design wheels with 265/35 summer performance tires* | These impressive wheels are standard on the S6 and are complemented by summer performance tires, which provide the driver with excellent traction.

7 18" seven-double-spoke wheels with 255/40 summer performance tires* | The eye-catching seven-double-spoke wheels are optional and come equipped with summer performance tires. [Optional on S6]

6



7



* Summer performance tires are designed for optimum performance and handling in warm climates. They are not suitable for cold, snowy or icy weather conditions. If you drive under those circumstances, you should equip your vehicle with all-season or winter tires, which offer better traction under those conditions. We suggest you use the recommended winter or all-season tires specified for your car or their equivalent. These summer performance tires also have a lower aspect ratio that aids performance and handling; however, in order to avoid tire, rim or vehicle damage, it is important that the inflation pressure is regularly checked and maintained at recommended levels. Serious wheel and tire damage may occur if the vehicle is operated on rough or damaged road surfaces, or upon encountering road debris or obstacles. Please also remember in making your selection that, while these tires deliver responsive handling, they may ride less comfortably and make more noise than other choices. Finally, these tires may wear more quickly than other choices. For more information on all of these topics, please consult the owner's manual, your local dealer or call 1-800-FOR-AUDI.

AMARETTO/BLACK LEATHER | DARK BROWN WALNUT WOOD INLAY



BLACK LEATHER | DARK BROWN WALNUT WOOD INLAY



BLACK SILK NAPPA LEATHER | GRAY BIRCH WOOD INLAY [S6 only]

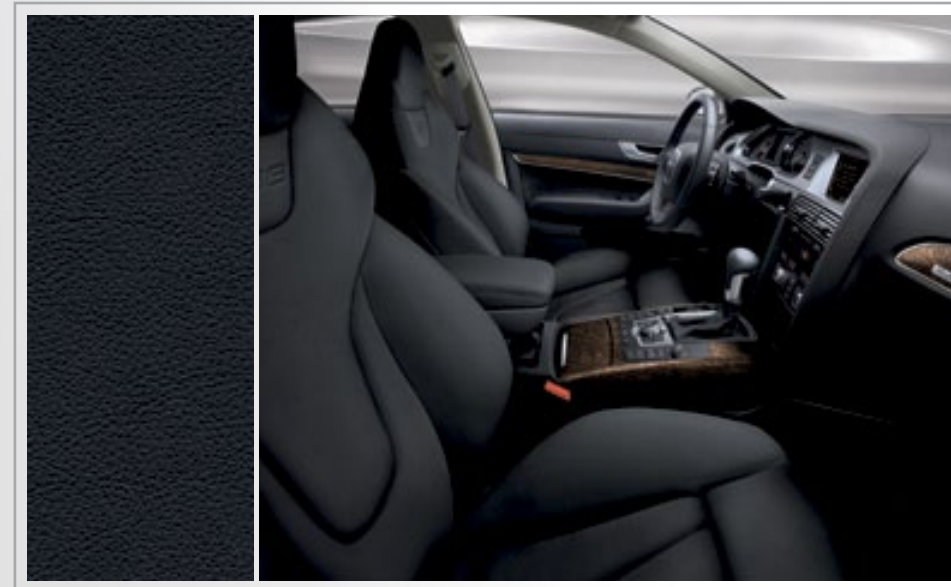

DECORATIVE INLAY OPTIONS

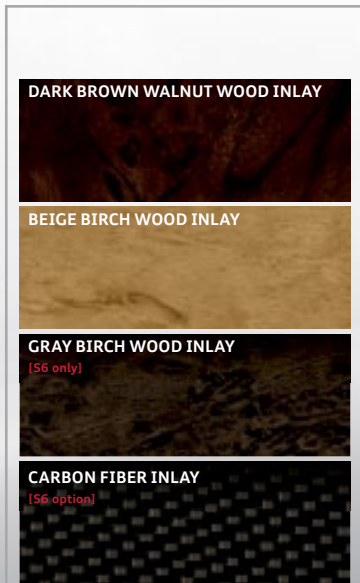

* Optional inlay shown

LIGHT GRAY LEATHER | DARK BROWN WALNUT WOOD INLAY



CARDAMOM BEIGE LEATHER | BEIGE BIRCH WOOD INLAY



SILVER SILK NAPPA LEATHER | CARBON FIBER INLAY* [S6 option]



Audi A6 | S6 Make Yours.



A6 Condor Gray METALLIC

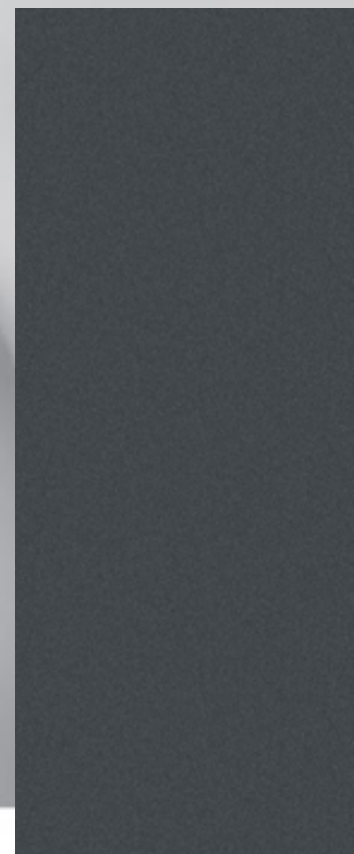

A6 Oyster Gray METALLIC

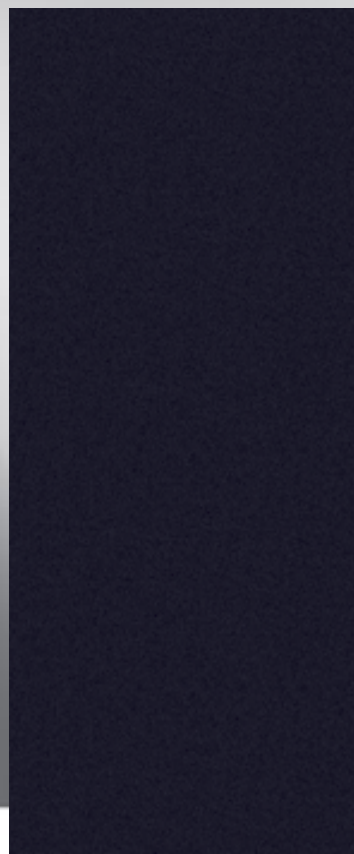

A6 | S6 Night Blue PEARL EFFECT



A6 | S6 Ice Silver METALLIC

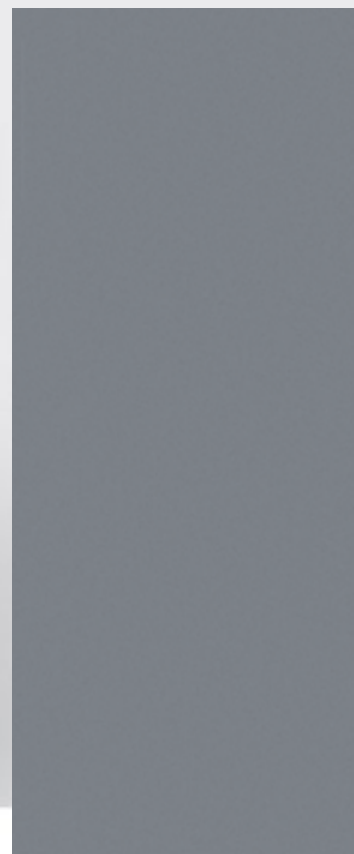

A6 | S6 Aventurine Blue PEARL EFFECT

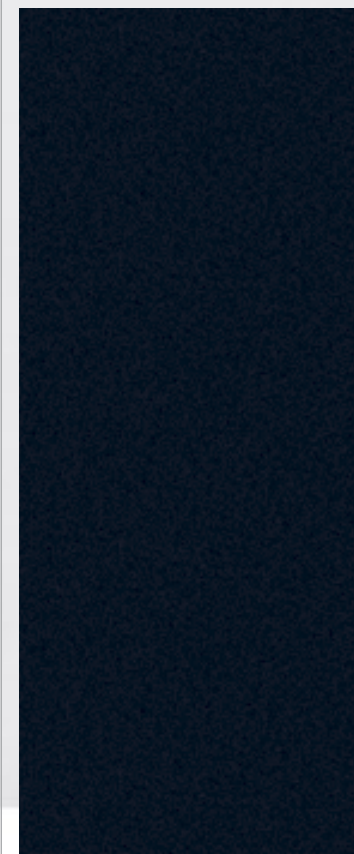
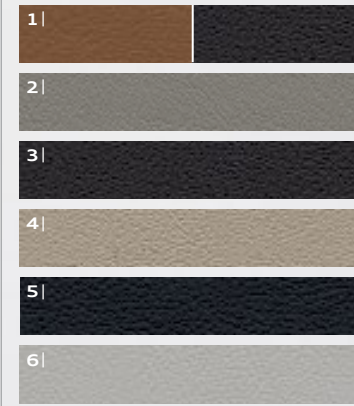

A6 | S6 Ibis White

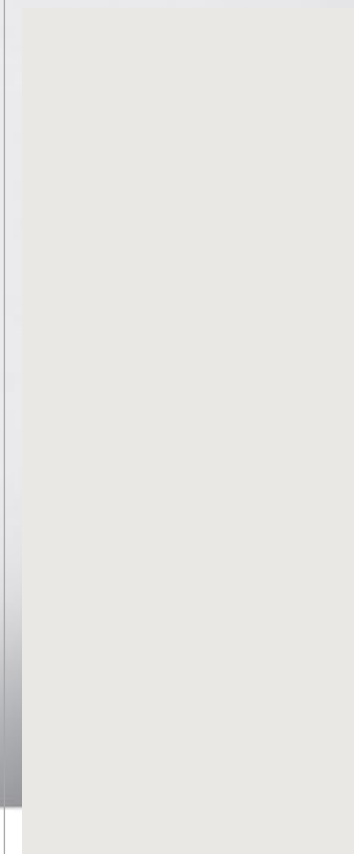

A6 | S6 Phantom Black PEARL EFFECT



A6 | S6 Quartz Gray METALLIC

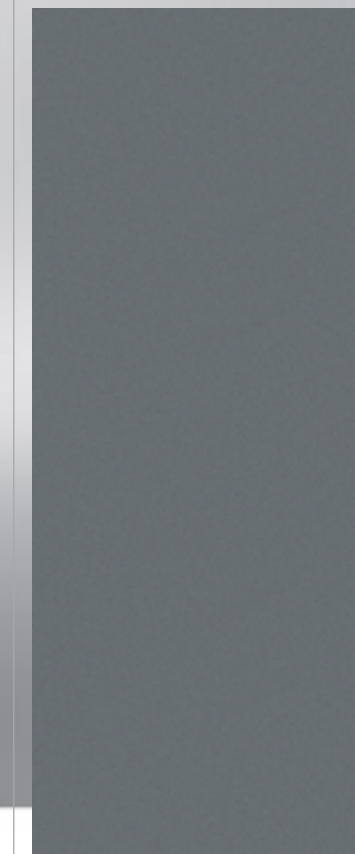

A6 | S6 Brilliant Black

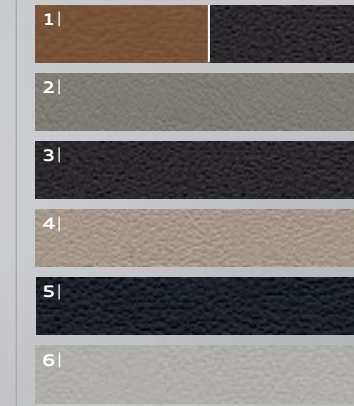

- 1 | Amaretto/Black
- 2 | Light Gray
- 3 | Black
- 4 | Cardamom Beige
- 5 | Black Silk Nappa leather [S6 only]
- 6 | Silver Silk Nappa leather [S6 only]

A6 | S6 2010 Specifications

Chassis/Technical	A6 3.2	A6 3.0T	A6 4.2	S6
Four-link front suspension with upper and lower control arms, stabilizer bar and individual, gas-charged coil springs/shock absorbers	S	S	S	S
Independent trapezoidal-link rear suspension with rigid subframe, stabilizer bar and individual, gas-charged coil springs/shock absorbers	S	S	S	S
Servotronic® speed-sensitive power steering – varies assistance based on vehicle speed	S	S	S	S
quattro® permanent all-wheel drive system utilizing torque-sensing center differential – 40:60 rear-biased torque split	-	S	S	S
Sport suspension calibration	0	0	0	-
S6 sport suspension calibration	-	-	-	S
multitronic® continuously variable transmission [CVT]	S	-	-	-
Tiptronic® automatic transmission	-	S	S	S
Fully galvanized steel unibody with multi-step anti-corrosion protection	S	S	S	S

Safety & Security	A6 3.2	A6 3.0T	A6 4.2	S6
Driver and front passenger advanced dual-stage airbag* supplemental restraints	S	S	S	S
Driver and front passenger seat-mounted side thorax airbag* supplemental restraints	S	S	S	S
Seat-mounted rear side airbags* for outboard seating positions	0	0	0	0
Sideguard® head curtain airbags* for both rows of seats	S	S	S	S
Front passenger occupant detection for airbag* supplemental restraints	S	S	S	S
Front three-point safety belts with automatic pretensioning and force limiters; height adjustable for front seating positions	S	S	S	S
Three rear three-point safety belts with belt force limiters for outboard passenger seating positions	S	S	S	S
Three rear head restraints	S	S	S	S
Safety belt reminder for driver and front passenger	S	S	S	S
Lower Anchors and Tethers for Children [LATCH] in rear seats	S	S	S	S
Pinch protection for passenger compartment windows	S	S	S	S
Central locking system with selective unlock feature	S	S	S	S
Impact protection – including reinforced high-strength steel/aluminum crossmembers, reinforced bumpers and rigid occupant cell	S	S	S	S
Tire pressure monitoring system	S	S	S	S
Electronic Stabilization Program [ESP®]	S	S	S	S
Anti-lock Brake System [ABS] with Electronic Brake-pressure Distribution [EBD]	S	S	S	S
Brake assist – a system that automatically senses emergency braking and applies maximum power boost to reduce overall stopping distance	S	S	S	S
Front ventilated disc brakes	S	S	S	S
Electromechanical parking brake	S	S	S	S
Reflectors in rear of all doors	S	S	S	S
Anti-theft vehicle alarm system with blinking theft-deterrent light	S	S	S	S

The table above represents the standard equipment on the Premium model. Many popular options are combined and available on the Premium Plus and Prestige models. Please see the package contents in this brochure for complete details.

* Airbags are supplemental restraints only and will not deploy under all crash circumstances. Always use safety belts and seat children in the rear, using restraint systems appropriate for their size and age.

† Summer performance tires are designed for optimum performance and handling in warm climates. They are not suitable for cold, snowy or icy weather conditions. If you drive under those circumstances, you should equip your vehicle with all-season or winter tires, which offer better traction under those conditions. We suggest you use the recommended winter or all-season tires specified for your car or their equivalent. These summer performance tires also have a lower aspect ratio that aids performance and handling; however, in order to avoid tire, rim or vehicle damage, it is important that the inflation pressure is regularly checked and maintained at recommended levels. Serious wheel and tire damage may occur if the vehicle is operated on rough or damaged road surfaces, or upon encountering road debris or obstacles. Please also remember in making your selection that, while these tires deliver responsive handling, they may ride less comfortably and make more noise than other choices. Finally, these tires may wear more quickly than other choices. For more information on all of these topics, please consult the owner's manual, your local dealer or call 1-800-FOR-AUDI.

‡ Your Audi vehicle is equipped with a phone preparation utilizing Bluetooth® interface to enable hands-free functionality [compatible mobile phones sold separately]. You will need a Bluetooth®-enabled mobile phone in order to utilize this function. Not all Bluetooth®-enabled mobile phone models are compatible with Audi phone preparation. Visit audiua.com/bluetooth, or contact your local Audi dealer for the latest listing of compatible phones. Audi recommends use of the Audi phone cradle [sold separately] with your mobile phone while operating this vehicle.

§ Audi Navigation plus depends on signals from the worldwide Global Positioning Satellite network. The vehicle's electrical system, and existing wireless and satellite technologies, must be available and operating properly for the system to function. The system is designed to provide you with suggested routes in locating addresses, destination and other points of interest. Changes in street names, construction zones, traffic flow, points of interest and other road system changes are beyond the control of Audi of America, Inc. Complete detailed mapping of lanes, roads, streets, toll roads, highways, etc., is not possible, therefore you may encounter discrepancies between the mapping and your actual location. Please rely on your individual judgement in determining whether or not to follow a suggested Audi Navigation plus route. Periodically, the mapping is updated, and a new DVD will be required in order to maintain the latest navigation information available to us. These will be available for purchase from time to time at an additional cost. Consult your dealer or call 1-800-FOR-AUDI for details.

Features	A6 3.2	A6 3.0T	A6 4.2	S6
17" five-spoke wheels with 245/45 all-season tires	S	S	-	-
18" five-Y-spoke wheels with 245/40 all-season tires	0	0	-	-
18" ten-spoke wheels with 245/40 all-season tires	-	0	S	-
18" five-arm wheels with 245/40 all-season tires	0	0	0	-
19" five-tri-spoke wheels with 255/35 summer performance tires†	0	0	0	-
19" five-parallel-spoke S design wheels with 265/35 summer performance tires†	-	-	-	S
18" seven-double-spoke wheels with 245/40 summer performance tires†	-	-	-	0
Sunroof with power tilt and open/close	S	S	S	S
Power adjustable and heated side mirrors with integrated LED turn signals	S	S	-	-
Power adjustable, auto-dimming and heated side mirrors with integrated LED turn signals	0	0	S	S
S Aluminum Optic side mirrors with integrated LED turn signals	-	-	-	S
Halogen headlights with integrated high and low beams and daytime running lights	S	S	-	-
Audi xenon plus headlights with automatic self-leveling	0	0	S	S
Programmable LED daytime running lights	0	0	S	S
Audi adaptive lights, including cornering lights	-	0	S	S
Headlight washers – high pressure, retractable and heated	-	-	S	S
LED rear taillights	S	S	S	S
Rear fog lights	S	S	S	S
Roof rails [Avant only]	-	S	-	-
Dark Brown Walnut wood decorative inlays	S	S	S	-
Beige Birch wood decorative inlays	0	0	0	-
Gray Birch wood decorative inlays	-	-	-	S
Carbon Fiber decorative inlays	-	-	-	0
Rain sensor for automatic windshield wipers	S	S	S	S
Four-spoke, multifunction, leather-wrapped steering wheel with controls for audio volume, Bluetooth® phone and audio seek functions	S	S	-	-
Four-spoke, multifunction, leather-wrapped steering wheel with shift paddles and controls for audio volume, Bluetooth® phone and audio seek functions	0	0	S	-
S6 multifunction sport steering wheel with controls for audio volume, Bluetooth® phone and audio seek functions	-	-	-	S
Manual tilt and telescoping steering column	S	S	-	-
Power tilt and telescoping steering column	-	0	S	S
Bluetooth® preparation for mobile phone	S	S	S	S
Auto-dimming interior mirror with compass	0	0	S	S
HomeLink® remote transmitter	S	S	S	S
Lighting Package	S	S	S	S
Leather-wrapped shift lever	S	S	S	-
Leather-wrapped/aluminum shift lever	-	-	-	S
Heated front seats	0	S	S	S

Features

	A6 3.2	A6 3.0T	A6 4.2	S6
Heated rear seats	o	o	o	s
Split folding 60/40 rear seatbacks	s	s	s	s
Pass-through with ski bag	-	-	-	s
S6 sport seats in Silk Nappa leather	-	-	-	s
Valcona leather seating surfaces	s	s	s	-
Twelve-way power front seats	s	s	s	s
Two-position memory function for driver's seat and outside mirrors	o	o	s	s
Power lumbar adjustment	s	s	s	s
Audi MMI® Navigation plus ⁵ – HDD navigation with voice control, rearview camera, color driver information display, six-CD/DVD changer	o	o	s	s
Audi music interface with iPod® integration, includes one cable for iPod® connection	s	s	s	s
Digital Signal Processing [DSP] extended sound system with ten speakers, six-CD changer in glove box, AM/FM radio, aerial diversity operated by MMI®; includes dynamic station list that continuously updates radio stations based on signal strength	s	s	-	-
BOSE® Surround Sound with 13 speakers and noise compensation AudioPilot®	o	o	s	s
SIRIUS® Satellite Radio with three-month trial subscription	s	s	s	s
Audi advanced key – keyless start, stop and entry	o	o	s	s
Monochrome trip computer	s	s	-	-
Rearview parking camera	-	o	s	s
Electronic cruise control	s	s	s	s
Power tailgate lift [Avant only]	-	s	-	-
Storage Package	s	s	s	s
Sun visors with vanity mirrors	s	s	s	s
Front center armrest	s	s	s	s
Audi side assist	-	o	o	o
S line exterior	-	-	s	-

Packages

	A6 3.2	A6 3.0T	A6 4.2	S6
Cold Weather Package: Heated front/rear seats, heated steering wheel	o	-	-	-
Cold Weather Package: Heated rear seats, heated steering wheel	-	o	o	-
18" Sport Package: 18" wheels with all-season tires, sport suspension, three-spoke, multifunction steering wheel with shift paddles	o	o	o	-
19" Sport Package: 19" wheels with summer performance tires ¹ , sport suspension, three-spoke, multifunction steering wheel with shift paddles	o	o	o	-

-	Not Available	o	Option	s	Standard
---	---------------	---	--------	---	----------



A6 Model Configurations

A6 Sedan 3.2 liter FSI® with multitronic® CVT and FrontTrak® front wheel drive

A6 Sedan/Avant 3.0 liter TFSI® with six-speed Tiptronic® automatic transmission and quattro® all-wheel drive

A6 Sedan 4.2 liter FSI® with six-speed Tiptronic® automatic transmission and quattro® all-wheel drive

Power and Performance 3.2

+ 3.2 liter DOHC V6 gasoline engine with FSI® direct injection and Audi valvelift system

+ Displacement: 3.2 liters [3123 cc]

+ Bore: 3.33 in. Stroke: 3.65 in. Compression ratio: 12.5:1

+ Horsepower: 265 hp @ 6500 rpm Torque: 243 lb-ft. @ 3250 rpm

+ 0-60 MPH in seconds: N/A

+ Top track speed[†]: 130 MPH

+ Fuel economy estimates, city/highway[‡]: N/A

Power and Performance 3.0T

+ 3.0 liter supercharged DOHC V6, gasoline engine with FSI® direct injection and variable valve timing

+ Displacement: 3.0 liters [2995 cc]

+ Bore: 3.33 in. Stroke: 3.50 in. Compression ratio: 10.5:1

+ Horsepower: 300 hp @ 5100 rpm Torque: 310 lb-ft. @ 2500-5100 rpm

+ 0-60 MPH in seconds: 5.9

+ Top track speed[†]: 130 MPH

+ Fuel economy estimates, city/highway[‡]: 18/26 MPG

Power and Performance 4.2

+ 4.2 liter DOHC V8 gasoline engine with FSI® direct injection and variable valve timing

+ Displacement: 4.2 liters [4163 cc]

+ Bore: 3.33 in. Stroke: 3.65 in. Compression ratio: 12.5:1

+ Horsepower: 350 hp @ 6800 rpm Torque: 325 lb-ft. @ 3500 rpm

+ 0-60 MPH in seconds: 5.8

+ Top track speed[†]: 130 MPH

+ Fuel economy estimates, city/highway[‡]: 16/23 MPG

S6 Model Configuration

S6 Sedan 5.2 liter FSI® with six-speed Tiptronic® automatic transmission and quattro® all-wheel drive

Power and Performance 5.2

+ 5.2 liter DOHC V10 gasoline engine with FSI® direct injection and variable valve timing

+ Displacement: 5.2 liters [5204 cc]

+ Bore: 3.33 in. Stroke: 3.65 in. Compression ratio: 12.5:1

+ Horsepower: 435 hp @ 6800 rpm Torque: 398 lb-ft. @ 3000-4000 rpm

+ 0-60 MPH in seconds: 5.1

+ Top track speed[†]: 155 MPH

+ Fuel economy estimates, city/highway[‡]: 14/19 MPG

A6 3.2/3.0T/4.2

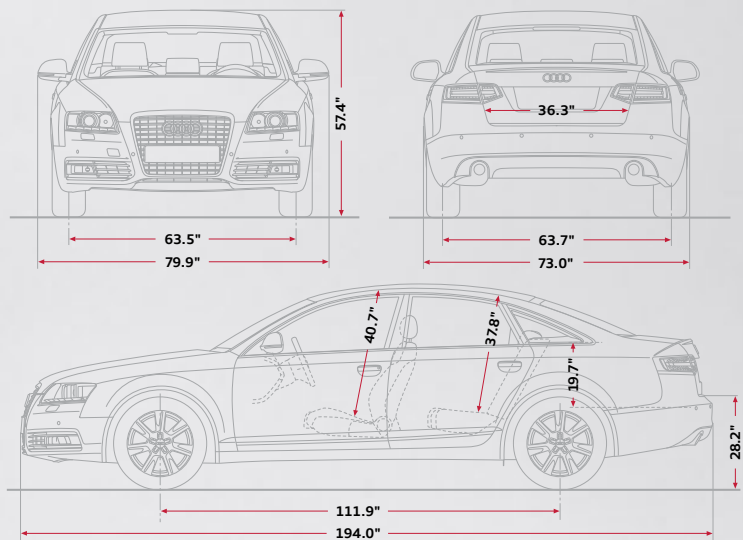

A6 Avant 3.0T

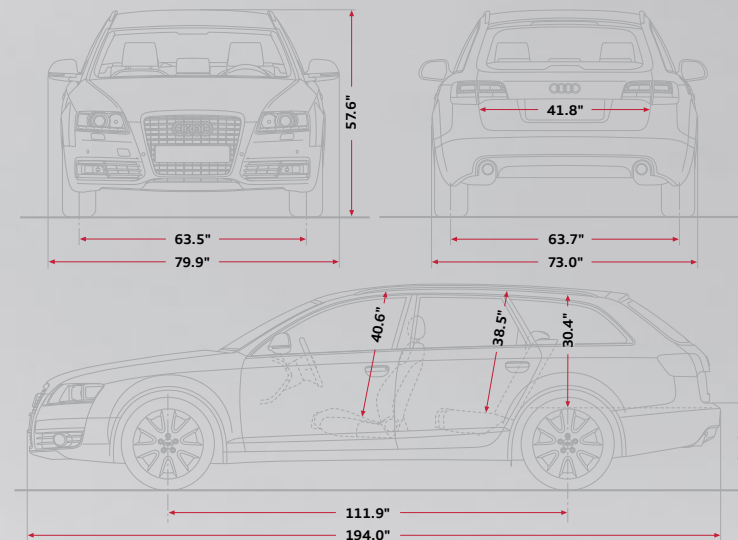

S6

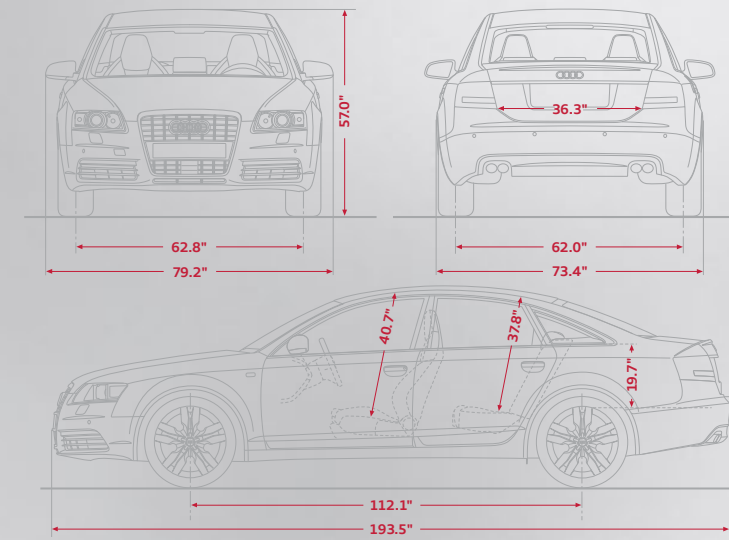

[†] Top track speed electronically limited to 130 MPH in the U.S. Obey all local speed and traffic laws. [‡] EPA estimates not available at time of printing. [§] EPA estimate; your mileage will vary. [¶] Top track speed electronically limited to 155 MPH in the U.S. Obey all local speed and traffic laws.

**With so much to offer, there is only one place
where you can experience it all.**

To fully interact with Audi, visit us online at any number of our special sites. From configuring your next Audi, to learning about the latest technology, to experiencing our passion for performance and racing, we invite you to explore the rich, stimulating world that is uniquely Audi.



audiusa.com/a6



Model Specific Info Summary

Dive into detailed information on the model you are considering. Each model in the Audi lineup has dedicated pages providing information on technical specifications, design, performance, safety and technology features, as well as extensive multimedia galleries.

audiusa.com/models



See All Models

Select from a remarkable array of engines, exterior colors, interior materials and progressive options to assemble your own unique Audi. You can print, request a quote or take your document to the nearest Audi dealer.

audiusa.com/technology



Technology Microsite

From the very beginning, advanced technology has been at the very heart of the Audi DNA. Contained in one convenient location, you will find great detail and demonstrations of many of our technologies.

audidrivingsite.com



Audi Driving Experience

The Audi driving experience and the Audi sportscar experience are designed to not only offer you a very special track experience in an Audi, but one that will leave you with a genuine appreciation for the technology that goes into every Audi vehicle.

audiusa.com/experience



Audi Experience

The experience section is your starting place for everything Audi. From an in-depth brand experience to a journey of our rich motorsports heritage or exclusive downloads, the online Audi Experience accommodates it all.

audi-collection.com



Audi Collection

Beautifully made. Beautifully designed. Faultlessly functional. All the qualities that distinguish our cars can also be found in our Audi collection. From performance wheels to products designed specifically with you and your particular Audi in mind to enhance the pleasure of driving and owning an Audi.

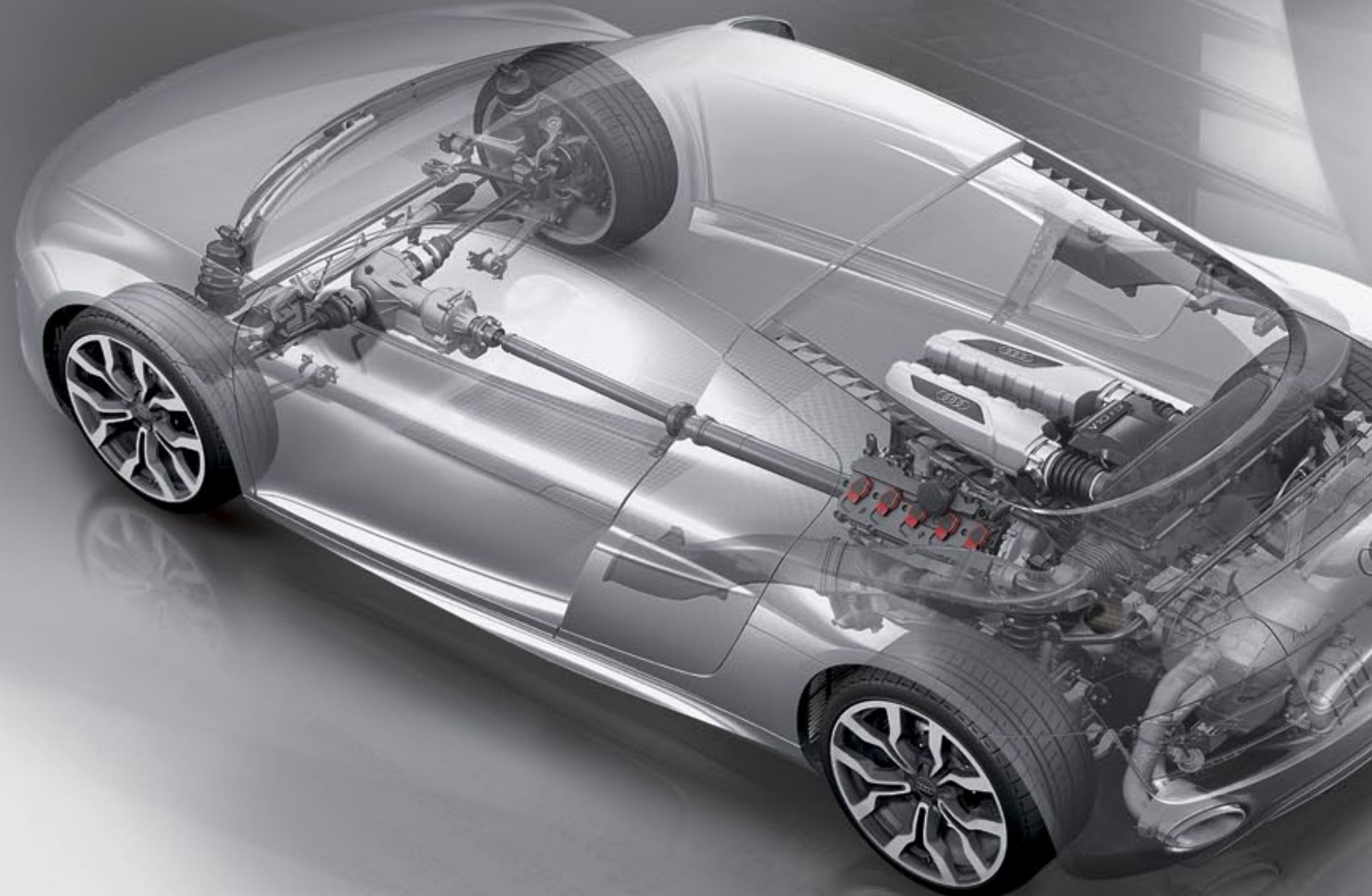

**Four driven wheels are a part
of what drives our progress.**

Nearly 30 years ago, the notion of a car with permanent four-wheel drive was revolutionary. Audi called it quattro® and its benefits would set a new benchmark for driver confidence and performance. The simple, yet profound result of sending power to all wheels means that snow-covered mountain passes, rain-slicked highways and gravel-strewn rural roads are no longer encountered with apprehension. While on smooth dry roads, quattro® offers a level of performance unachievable by two-wheel drive cars.

The advantage of all-wheel drive was most apparent when Audi introduced quattro® to the World Rally Championship. quattro® seemed to defy physics with startling acceleration and remarkable traction. The result was an astounding 24 wins and a number of World Championships. If that wasn't enough of an endorsement for quattro®, it was later deemed an "unfair advantage" and banned from road racing altogether after repeatedly dominating the field.

Today, in that same competitive spirit, quattro® all-wheel drive continues to be refined. In Audi vehicles with a longitudinal engine configuration, quattro® is essentially a mechanical system with a self-locking center differential and continuously variable torque distribution. quattro® instantly responds to wheel speed differences and dynamically adjusts power to the wheels with the best traction. It is supported by advanced electronic control systems that together offer numerous benefits over other all-wheel drive systems. Featuring a 40:60 rear torque bias, the latest version of quattro® offers sportscar-like performance and handling with uncompromised all-wheel drive traction.

The power of quattro® is its ability to inspire driver confidence,
giving you traction when you need it, where you need it, regardless of road conditions.



Together the future is ours.

August Horch founded this company on one word: **Progress**. Back in 1909.

To us, it is taking what seems undoable and then doing it. It is discovering what no one else has bothered to discover. It is turning skeptics into believers, and it is taking the thinking that wins on the racetrack and putting it on the road. Relentlessly designing, innovating, engineering and racing for the past 100 years have yielded amazing progress in our quest for the Truth. And although the Truth is absolute, it's in a constant state of motion always revealing new limits and opportunities. For instance, what seemed improbable has become the standard as we have created a diesel engine so quiet, so clean, so efficient and so powerful we put it to the ultimate test competing in the 24 Hours of Le Mans... winning three years in a row. But aside from walking away with trophies, we walked away with a deeper understanding of what to engineer into our cars for the street. The remarkable capabilities of TDI[®] clean diesel power, the all-wheel drive confidence of quattro[®], and the increased power and efficiency of FSI[®] are but a few of those strands of DNA that have brought us that much closer to the Truth.

And it is that quest for the Truth that is behind every pencil line we draw, every calculation we make and every idea we deem not good enough. And although they may prove to be remarkable achievements in their own right, they represent a greater commitment to what is most important: **Truth in Engineering**.

Note: A word about this brochure. Audi of America, Inc. believes the specifications in this brochure to be correct at the time of printing. However, specifications, standard equipment, options and colors are subject to change without notice. Some equipment may be unavailable when your vehicle is built. Please ask your dealer for advice concerning current availability of standard and optional equipment and your dealer will verify that your vehicle will include the equipment you ordered. Vehicles in this brochure are shown with optional equipment. See your dealer for complete details on the new-vehicle limited warranty, twelve-year limited warranty against corrosion perforation and Audi 24/7 Roadside Assistance. [Roadside assistance coverage provided by Road America in the U.S. Certain conditions apply, see your dealer for details.] Tires supplied by various manufacturers. "Truth in Engineering" is a trademark of Audi of America, Inc. "Audi", "quattro", "A6", "S6", "Avant", "MMI", "multitronic", "FrontTrak", "FSI", "TFSI", "Sideguard", "Audi Financial Services", "singleframe" and the four rings logo are registered trademarks of AUDI AG. "Servotronic" is a registered trademark of the AM General Corporation. "BOSE", "Richbass" and "AudioPilot" are registered trademarks of the BOSE Corporation. "Tiptronic" is a registered trademark of Dr. Ing h.c. F. Porsche AG. "ESP" is a registered trademark of Daimler AG. "Barracuda" is a registered trademark of Mont Blanc. "Stormshield" is a registered trademark of Guilford Mills Inc. "HomeLink" is a registered trademark of Prince Corporation, Holland, Michigan. Prince is a wholly owned subsidiary of Johnson Controls. "SIRIUS" is a registered trademark of SIRIUS Satellite Radio, Inc. "SD" is a registered trademark of SD-3C, LLC. "Bluetooth" is a registered trademark of Bluetooth SIG, Inc. "iPod" is a registered trademark of Apple, Inc.

©2009 Audi of America, Inc.