

TATA MOTORS



India's 1<sup>st</sup>  
Delivery Van  
with  
**Power  
Steering!**

The all new  
Winger Cargo from  
Tata Motors

**winger**  
C A R G O

# Technical Specifications

Attributes	Winger DV
Engine	4 cyl, 90 HP TCIC
Suspension	Front: independent, Rear: leaf spring
Gear box	Transaxle 5-speed
Wheel	14"
Gradeability	37%
Ground clearance (mm)	165
Turning radius (m)	6.4
Steering	Power
Wheelbase (mm)	3200
GVW (kg)	2850
Kerb weight (kg)	1650
Payload (kg)	1200
Body (LxBxH) (mm)	2750 x 1650 x 1900
Overall (LxBxH) (mm)	4920 x 1905 x 2445
Fuel	Diesel



## Features & benefits

- Front wheel drive for greater fuel efficiency
- Ready-to-use factory built monocoque pressed steel body
- 6.4-metre turning radius for easy manoeuvrability
- Low floor height for easy loading & unloading
- Large branding area on vehicle body
- Power steering
- Independent front suspension for comfortable rides
- BSIII compliant
- Compressed engine & driveline compartment for maximum space

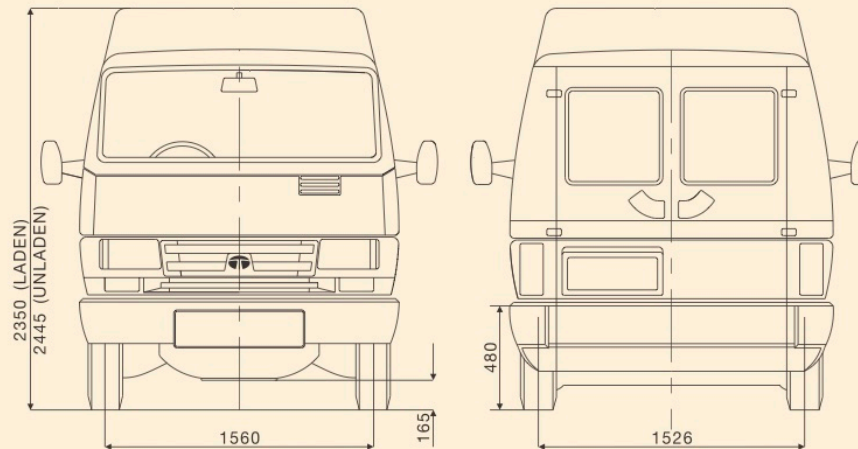

All measurements are in mm

For further details, please contact: Tata Motors Limited, 20<sup>th</sup> Floor, Tower 2, One Indiabulls Centre, 841 Senapati Bapat Marg, Mumbai 400013.  
Tel : 91 22 66586000 Fax: 91 22 66586010.  
Our toll-free no. 1 800 20 97979;  
visit [www.tatamotors.com](http://www.tatamotors.com)

**winger**  
C A R G O