

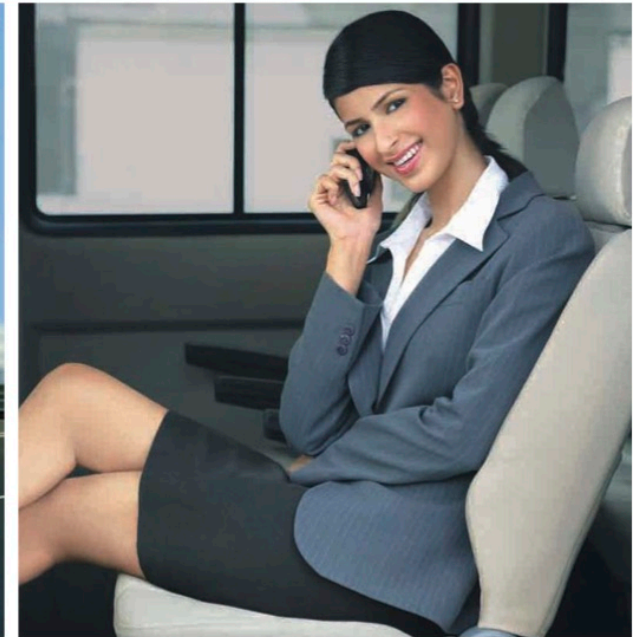

Brings people closer. Takes your business further.



Ab dooriyan ban gayi nazdikiyan

TRUCKS & BUSES FROM
TATA MOTORS

winger
MAXIVAN

Designed to reduce distances. Between people and places.



Winger

A world of applications

The Winger Maxi Van has been thoughtfully designed to provide a speedy and comfortable means of transport. Travelling in the Winger makes distances disappear, helping passengers arrive at their destination in better shape.

The Winger offers several applications:

- Passenger travel between cities, small towns & villages
- Trips for families to tourist destinations
- Pick-up and drop of corporate employees
- Pick-up and drop of BPO employees
- Airport transfers, sight-seeing trips for hotel guests, transport of delegates at corporate conferences and more
- School bus



winger
MAXIVAN



Comfortable

No more sweaty journeys
in jam-packed vehicles

With India's economy on the fast track, there's a transformation taking place everywhere in the country. Lifestyles are changing, spending is increasing, communication is improving, even roads are becoming wider and better.

Reflecting this change is the new Winger from Tata Motors, India's first Maxi Van. As your passengers step into the Winger, they will discover more length, width and height of cabin. That adds up to more space and cool comfort for them... and more passengers per trip for you.

Add to that the smooth ride that makes distances come closer. And you can be sure your passengers will come back to the Winger. Again and again.



The Winger Range

- ◆ **Standard:** 12 & 13-seater with Power Steering (Non-AC; Flat Roof)
- ◆ **Deluxe:** 12 & 13-seater with Power Steering (AC / Non-AC; Flat Roof / High Roof)
- ◆ **Luxury:** 9-seater high end variant, with Power Steering (AC; Flat Roof)

The Winger is designed to accommodate a host of additional fitments, so that you can customize it to your preference.



Tata Motors introduces yet another commercial vehicle that sets the trend for others to follow. The new **Winger**, **India's first Maxi Van**. International in looks yet 100% indigenous, the **Winger** is in a class of its own. Designed to keep your passengers smiling, and your business running.

The first thing that strikes you about the **Winger** is that it offers the best of both – the comfort of a car and the spaciousness of a bus. Reason why we call it a Maxi Van.

The **Winger** is actually a range of Maxi Vans with a choice of three variants – **Standard**, **Deluxe** and **Luxury**. They differ in features, but offer one thing in common – speedy returns on your investment.

Read on to discover more about the **Winger**. The Maxi Van that gives passengers a well-deserved upgrade. So that they can travel distances with dignity.

winger
MAXIVAN

Comfortable Winger Standard



■ Comfort for your passengers

- ◆ The monocoque construction ensures low car-like noise, vibration and harshness (NVH) levels, for silent drives.
- ◆ Front independent suspension and anti-roll bars with hydraulic shock absorbers ensure a bump-free ride.
- ◆ The Hi-Comfort seats towards the entry and exit tumble forward, making it easy for passengers to move to the very last row of seats.
- ◆ The front and rear cabin lights in the vehicle ensure adequate lighting at night.
- ◆ There's provision for **extra fitments** such as roof luggage carrier, cigarette lighter, mobile charger, music system, ashtrays, passenger cabin fans and more.
- ◆ Twin rear doors swing completely both inside and out, for easy storage and removal of baggage.

The Standard variant of Winger Maxi Van runs on a **Hi-Drive** engine with 68 HP @ 4500 rpm power. It has **Hi-Comfort front-facing seats** made from soft dual tone PVC lined fabric. You can choose to carry 12 or 13 passengers between cities, small towns and villages. What makes it stand out is its **power steering** for easy driving. And its short **turning radius of 5.65m** which enables it to run even on narrow roads.

Both passenger and driver comfort are what make the Winger an unmatched vehicle. It's a travel experience that will keep them smiling all the way.

■ Comfort for your driver

- ◆ The driver's seat offers a **3-way movement**: vertical, sliding and reclining, with an adjustable headrest. For your driver, it adds up to more driving comfort and less fatigue.
- ◆ The wide windshield, outer rear view mirror on both right and left sides, and anti-glare inner rear view mirror on windshield offer a panoramic view of the road, adding to driving safety.
- ◆ The classy design of the front dashboard is supported by functional features like digital clock, trip meter, glove box with lock, coin case, storage space for paper, cup holder and ashtray



With so many features in the Standard variant itself, you can imagine what the Winger Deluxe and Winger Luxury have to offer!

Winger Deluxe

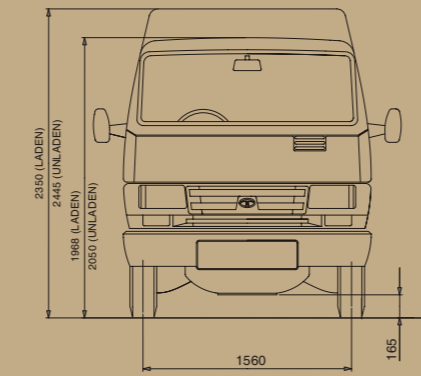

A world of space and comfort is what makes the Winger Deluxe stand out. Making it the ideal vehicle for travel by corporate and BPO employees, in metros and cities. Its **Hi-Back seats**, with soft dual tone PVC lined fabric, make travelling a pleasure. And its **Hi-Drive** engine, with 90 HP @ 4300 rpm power and 190 Nm torque, offers the kind of pick-up and speed that makes distances seem a lot closer. And its 3200mm wheel base ensures better legroom.

The Winger Deluxe offers **4 convenient options**. You can choose from an AC or a Non-AC Flat Roof version, or an AC or Non-AC High Roof version. It can carry 12 or 13 passengers, according to your preference.



■ A world of comfort

- ◆ Hi-Back seats with integral headrest.
- ◆ **Front console** and **roof-mounted blowers**, along with tinted glasses in the AC versions, ensure that even passengers in the last row of seats travel in cool comfort. Air blowers and large sliding windows in the Non-AC version keep passengers comfortable throughout the journey.
- ◆ The High Roof option, with a height of 2445mm, offers passengers comfortable entry and exit. And the **internal height of 1900mm** offers hassle-free movement inside the vehicle.
- ◆ Seat storage pocket and spot lamps offer personal space for every passenger.

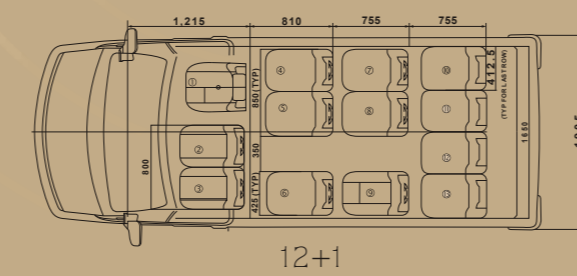
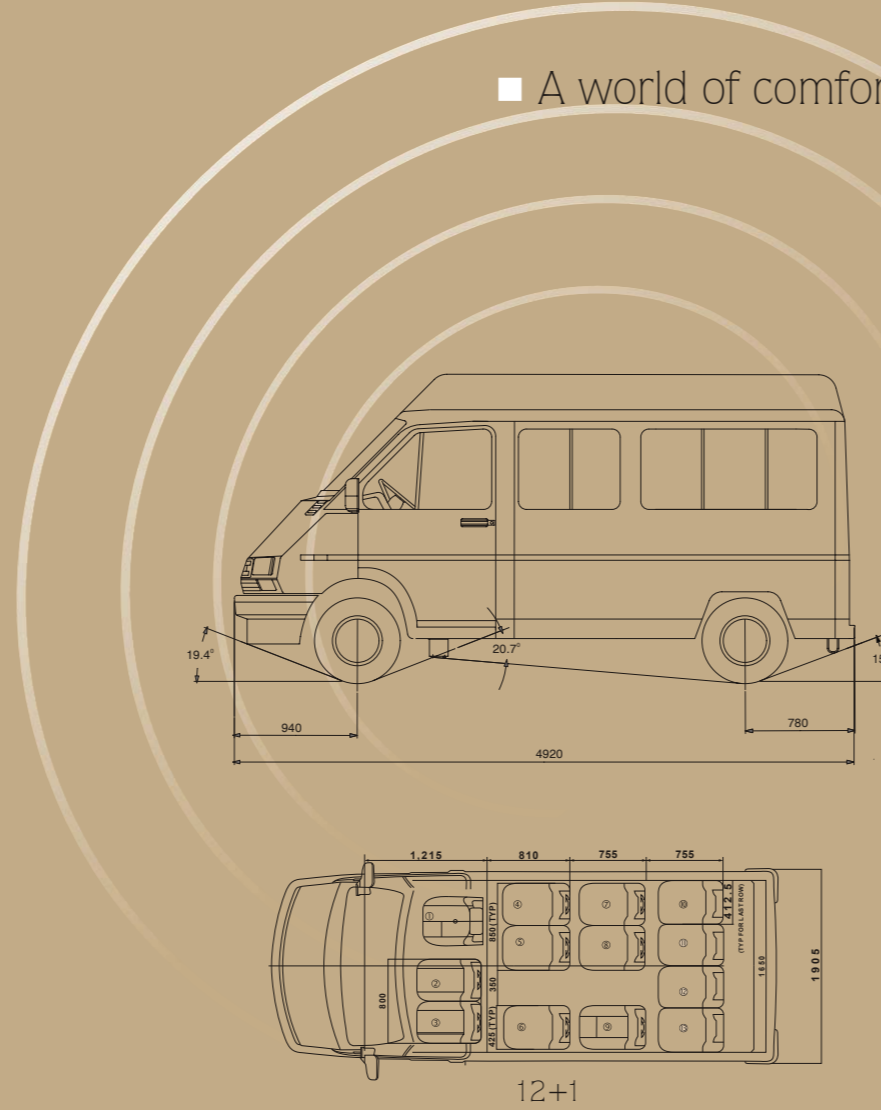

12+1

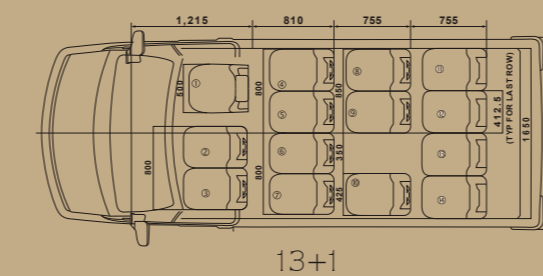

13+1





Comfortable

Winger Luxury

The Luxury variant is the top end version of the Winger. It maximizes passenger comfort with several features, including its **9 individual bucket seats** with **adjustable headrests**. Its **body-coloured exteriors** add to its attractive looks. And its luxurious comfort makes it the perfect choice for pleasure trips to nearby destinations, airport transfers, sight-seeing trips for hotel guests, transport of delegates at corporate conferences, even family picnics. It runs on a Hi-Drive engine, with 90 HP @ 4300 rpm power and 190 Nm torque. This gives it the kind of pick-up and speed that enables passengers to arrive on time and in better shape.

■ Luxury features

- ◆ All 9 passenger luxury seats are individual and reclining, with adjustable headrest, armrests and seat belts.
- ◆ AC is a standard fitment with roof-mounted vents
- ◆ The metallic body coloured bumpers and outer rear view mirror on both sides add to safety and aesthetics.
- ◆ The plush interior trims are almost car-like, creating an ambience of luxury and space.

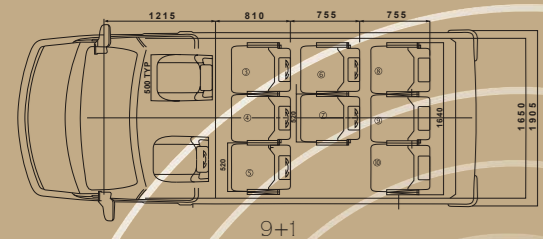

winger
MAXIVAN



Technology that makes every trip
a safe, smooth and pleasant drive

The Winger incorporates several cutting-edge technological features. These make it the ideal vehicle for short distance journeys between cities, small towns and villages, as well as within the city.

The Deluxe and Luxury variants run on a **Hi-Drive** engine powered by 90 HP @ 4300 rpm. This, along with a 3200 mm wheelbase, adds up to unmatched speed and comfort. On the other hand, the variant with the short wheelbase runs on a **Hi-Drive** engine powered by 68 HP @ 4500 rpm. This gives it the required speed that ensures **faster trip times** for you.

Moreover, all variants of the Winger are designed with a **low centre of gravity** and a host of car-like features. Which makes it possibly the **safest** vehicle in its class, in India today.

Cutting-edge





Cutting-edge features

- ◆ Front suspension: McPherson Strut for smoother rides.
- ◆ Rear suspension: Leaf springs, to support heavy loads.
- ◆ Gradient 39% (TCIC) & 28% (NA) give best-in-class climbing power.
- ◆ Added floor reinforcements enable higher load-bearing capacity.
- ◆ 165 mm ground clearance tackles any road condition (except off-road).
- ◆ Excellent visibility with front & rear fog lamps.
- ◆ Reflex reflectors (doors) cautions other vehicles.

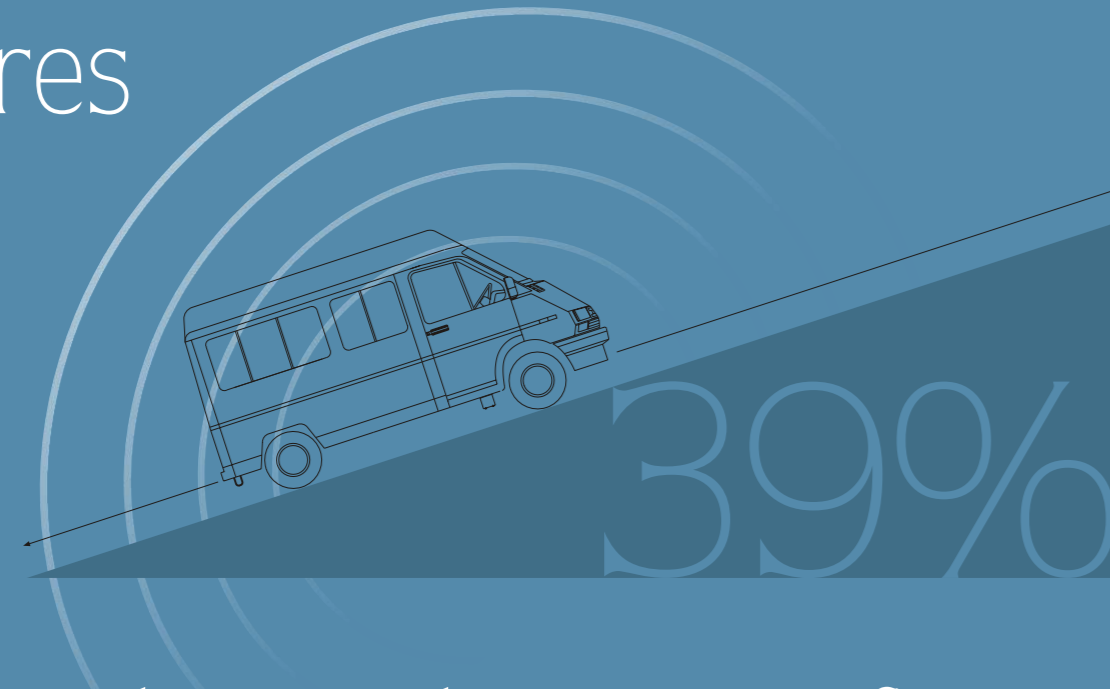

Technology features that enhance safety



- ◆ Front brakes: ventilated discs mean less maintenance costs; Rear brakes: drum with **LSPV** (Load Sensing Proportion Valve). **LSPV gauges the load on all 4 wheels, for efficient braking under variable load conditions, so as to avoid swirl and sway of the vehicle.**
- ◆ Brake booster with TMC ensures efficient braking.
- ◆ Centre of gravity (unladen), which is 690mm for Flat Roof and 720mm for High Roof, offers better stability.
- ◆ Seat belts: 3-point ELR belts for driver & co-driver; lap belts for passengers ensure maximum safety.





winger
MAXIVAN



Cost-effective

More trips for Winger,
faster returns for you

As India's first Maxi Van, the Winger makes a lot more business sense. With its 60-litre fuel tank, it can run up to 700 km without refuelling. Add to that a maximum speed of 115 kmph for the Standard variant and 125 kmph for the Deluxe and Luxury variants. Together, they add up to **more trips per day** for you.

In fact, whichever way you look at it, the Winger assures you of **faster returns on your investment**.



■ Performance features

- ◆ **Power-to-weight ratio** of 25 for Standard and 32 for Deluxe & Luxury. **Maximum torque** of 115Nm @ 2000-3000 rpm with 68 HP engine for Standard, and 190Nm@ 2000-3000 rpm with 90 HP engine for Deluxe & Luxury. Whichever variant you choose, you are assured of lesser turnaround time and, consequently, **more trips and more revenue**.
- ◆ BSII & BSIII emission standards – environment-friendly & fuel efficient.
- ◆ Turning radius: 5.65m for Standard and 6.4m for Deluxe and Luxury. This helps the Winger run even on narrow roads, enabling you to reach **interior locations** too.
- ◆ Cutting edge aerodynamics.
- ◆ **100% indigenous**, adding up to **lower maintenance costs**.
- ◆ Warranty: 18 months/1,50,000 km.

winger
MAXIVAN



Clear choice

From India's most reliable name
in commercial vehicles

The Winger Maxi Van comes to you from Tata Motors, India's largest integrated automobile company. Powered by a 22,000-strong work force, it is guided by the vision to be "best in the manner in which we operate, best in products we deliver, and best in our value system and ethics".









Your purchase of the Maxi Van will be backed by the trusted Tata name. With top class after sales service, through the widest network of Authorised Service Stations, you are assured of maximum possible running time.

Indeed, the Winger is a choice hard to match and an investment hard to resist.

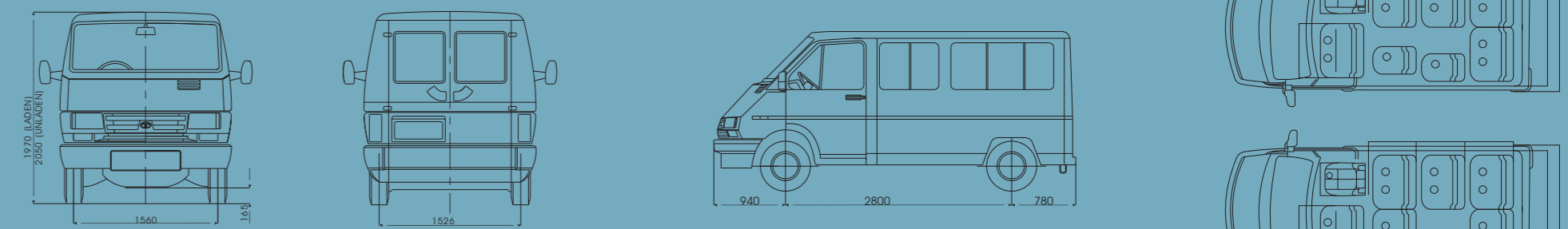

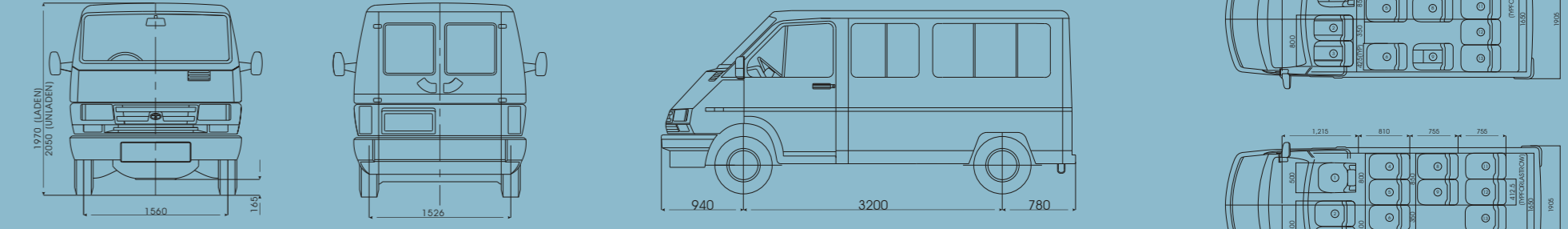

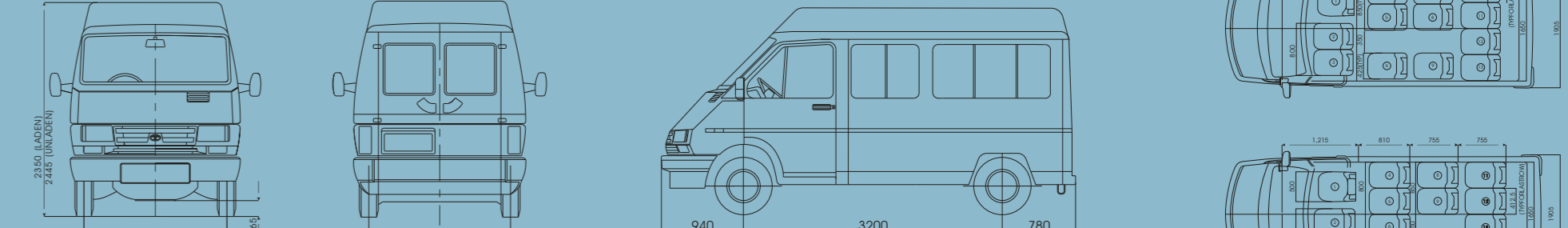
TATA WINGER RANGE – INDIA'S FIRST MAXIVAN

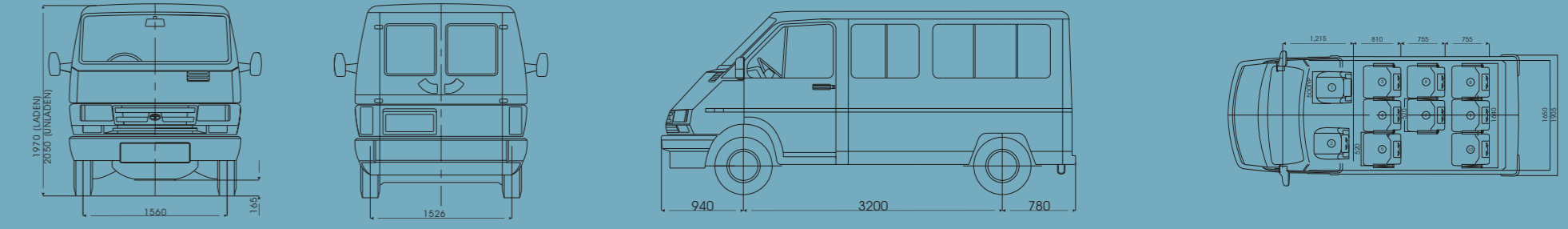
<h2>STANDARD</h2>  <p>Flat Roof 2800 WB</p>		<p>Non AC</p>	<p>Seating 12+1</p>	
<h2>DELUXE</h2>  <p>Flat Roof 3200 WB</p>		<p>Non AC / AC</p>	<p>Seating 12+1</p>	
<h2>DELUXE</h2>  <p>High Roof 3200 WB</p>		<p>Non AC / AC</p>	<p>Seating 12+1</p>	 <p>All Deluxe variants have an option of factory-fitted AC</p>
<h2>LUXURY</h2>  <p>Flat Roof 3200 WB</p>		<p>AC</p>	<p>Seating 9+1</p>	 <p>Winger Luxury has a standard factory-fitted AC</p>

TATA MOTORS

For more information, please visit our website: www.winger-tatamotors.com

You can also contact our Sales Office: 26th Floor, Centre 1, World Trade Centre, Cuffe Parade, Mumbai 400 005.

Tel: (022) 6656 1800 / 1816; Fax: (022) 6636 0408 / 0409. Email: businfo@tatamotors.com

The illustrations may show accessories and items of optional equipment which are not part of standard specifications. Colours may vary slightly from those shown, owing to printing process.
Tata Motors reserves the right to change and vary the design, technical details and specifications without prior notice, as the company policy is of continuous product improvement.