



RENAULT
Passion for life

New
Renault MEGANE R.S.



Contents

 CLICK BELOW TO VIEW SECTION

- Exterior Design
- Interior Design
- 40 years of Renault Sport
- Engine
- Efficiency and Performance
- Agility and Stability
- R.S. Monitor
- Launch Control
- R.S. Vision
- Colours
- Wheels
- Model Range
- Vehicle Specifications
- Equipment and Options
- Dimensions
- The Renault Promise





Catch me, if you can!





Motorsport in its genes

The New Renault MEGANE R.S. is an impressive car. A car built to arouse your driving instincts with wings extended by 60mm, and special bumpers featuring a Formula 1® blade at the front and a wide diffuser at the rear. Sitting squarely on its 18- or 19-inch wheels, the front end features LED lights with the additional multi-reflector R.S. Vision system. It includes a central exhaust exit, side extractor vents and a wide lip spoiler with exclusive Orange Tonic bodywork, The New Renault MEGANE R.S. is clearly designed for sporting performance.





A sporty cockpit

As soon as you see the interior - carbon grey with touches of red - you want to get behind the wheel. The New Renault MEGANE R.S. invites you to take to the road, with Alcantara sports seats designed for support, a leather steering wheel* and personalisable dashboard. At the same time, the short gear shift** and aluminium pedal assembly take you into a new dimension, the world of R.S. sporting performance.

*Nappa leather. **Manual Cup model only.



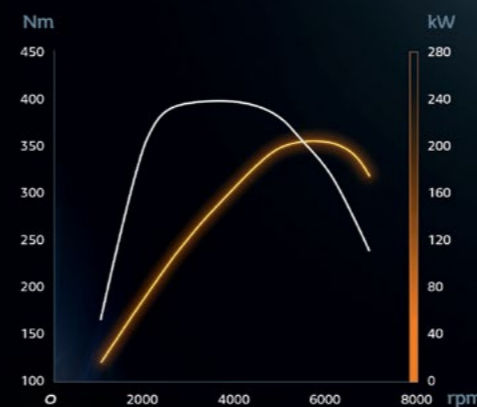

Power : 280hp / 205Kw at 6000rpm

Torque : 390Nm at 2400rpm

Engine 4 cylinders

1.8 - litre (1.798 cc)

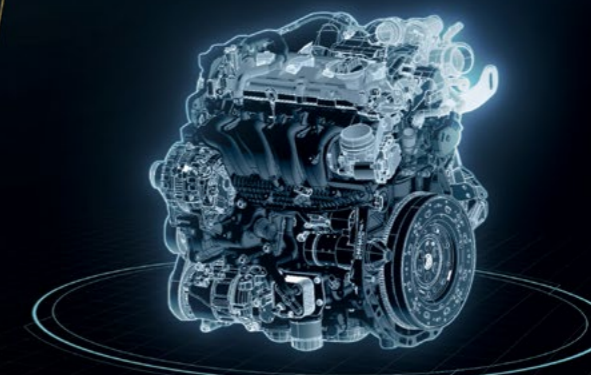

A passion for motorsports spanning 40 years

Involved in motorsports for 40 years and still counting, our engineers trialed the solutions featured on the New Renault MEGANE R.S on the track. Building on the infinite legacy of an exceptional championship, through efficiency, braking quality, reinforced roadholding and powertrain reliability, along with onboard telemetry, steering wheel paddles and launch control!

F1® Technology inspired power

The New Renault MEGANE R.S. features a new version of the 1.8-litre direct injection turbo engine, derived from Alliance synergies. This version develops a power output of 205 kW at 6,000rpm and peak torque of 390Nm available from 2,400 to 4,800rpm. Renault Sport's engine specialists designed a completely new cylinder head, with a reinforced structure and more efficient cooling. Work also focused on the Twin Scroll turbocharger, to improve torque at low revs. To increase the supply of cool air to the engine, the air intake was redesigned with the addition of a second air inlet and a new, larger filter. The engine has also been given surface treatments taken from the world of racing, such as DLC(Diamond Like Carbon) for the valve lifters and Mirror Bore Coating for the cylinder sleeves.



Efficiency and performance

The New Renault MEGANE R.S. benefits from the knowhow of Renault Sport in adapting motorsports technologies to production sports vehicles. It features a range of driving aids for any type of road and any situation.

1.

1. Suspension with hydraulic compression stops: With the addition of hydraulic compression stops, the shock absorbers absorb impact better. This technology delivers spectacular results in terms of progressive control, comfort and performance.

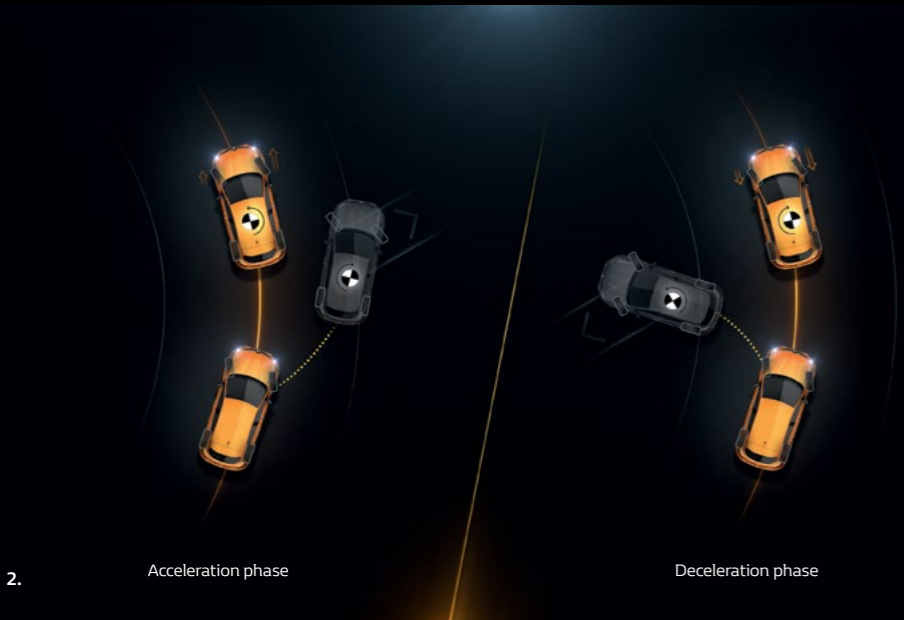

2.

2. New Torsen® limited slip differential*: associated with the Cup chassis, it has an asymmetrical transfer rate for acceleration and deceleration to improve acceleration power and cornering speed. Efficiency and performance

*Available on Megane R.S. 280 Cup

Engine
1,8l - 205 kW / 390 Nm

R.S. Vision

Limited Slip Differential (Cup Chassis)

Gearbox Manual & EDC

R.S. Monitor Data Display

Independent steering axis front suspensions

4 hydraulic compression stops

4CONTROL

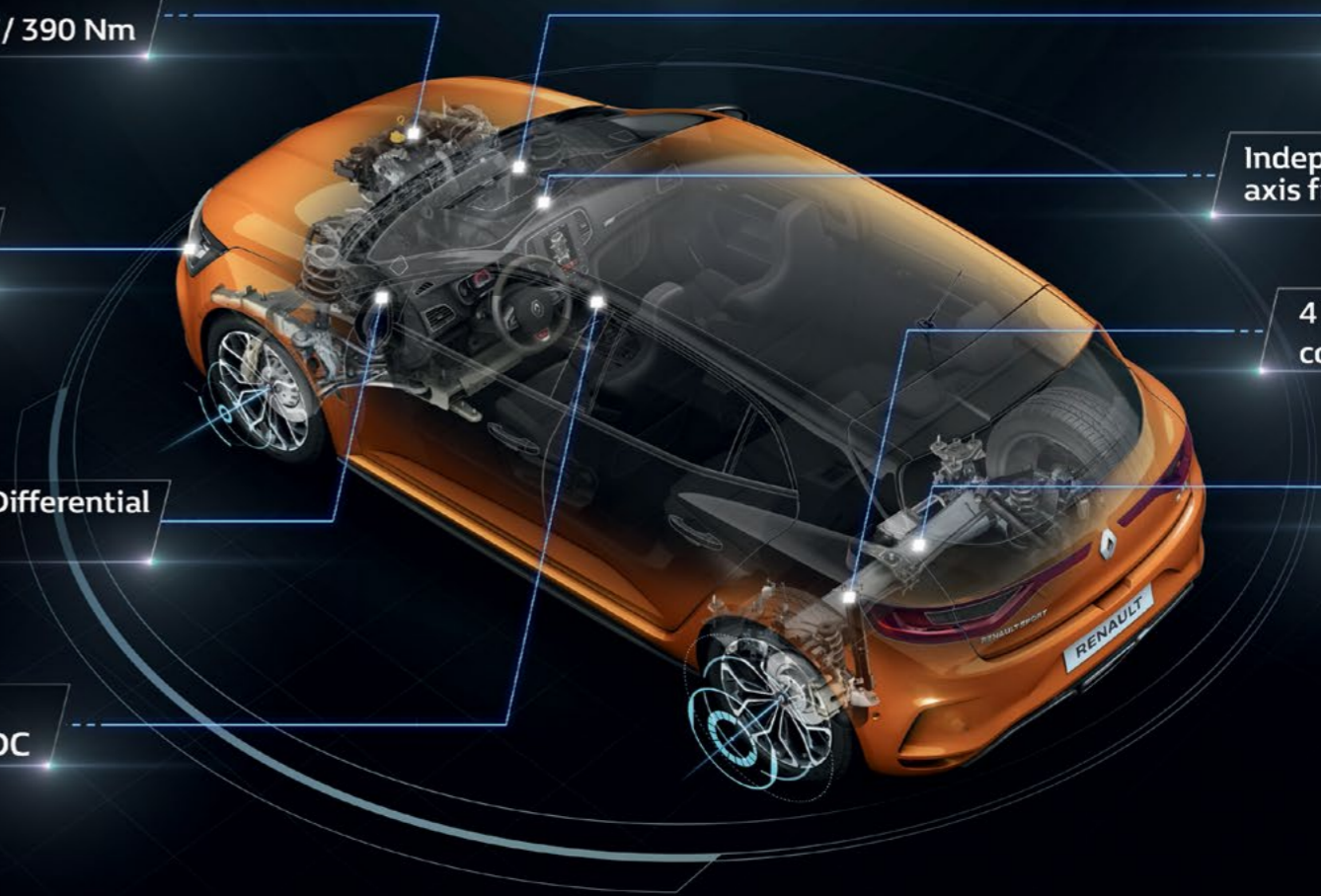



Agility and stability

4CONTROL technology contributes to incisive steering and optimised roadholding for a precise, surefooted drive. At low speeds, the system turns the rear wheels in the opposite direction to the front wheels. At speeds of over 60 kph (100 km/h in Race mode), all four wheels turn in the same direction. You are in control of the road.

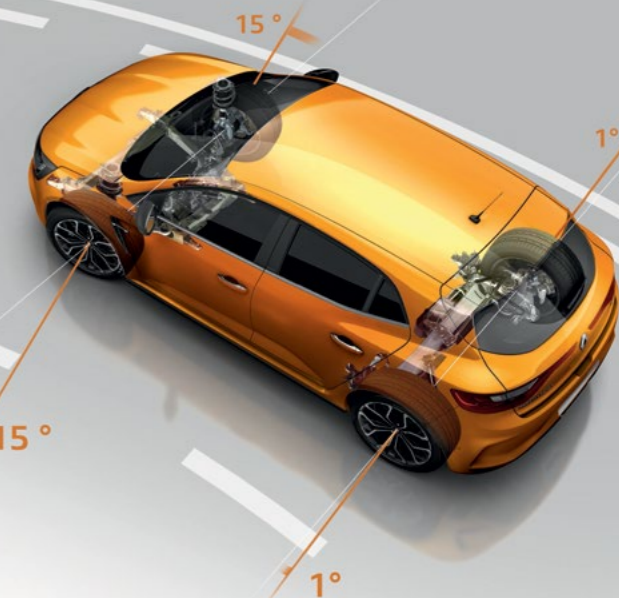
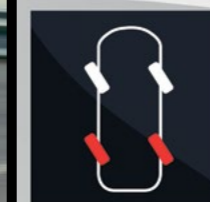
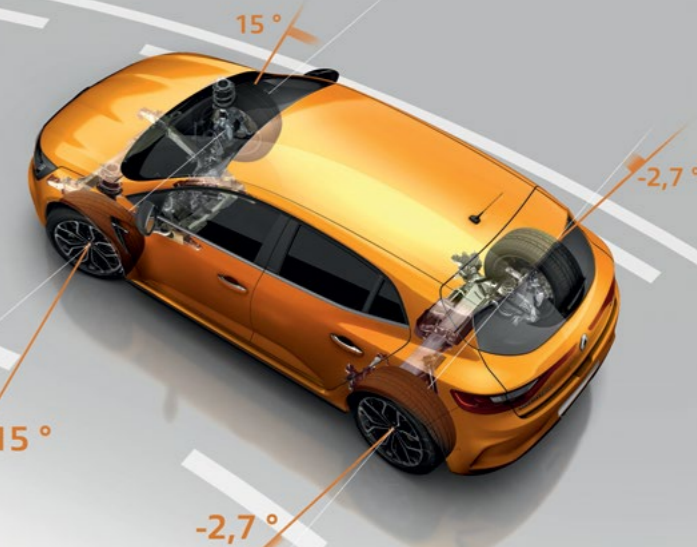
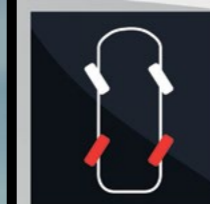



Display and analyse your performance

Your driving talents deserve to be recognised, stored and analysed! The onboard telemetry system R.S. Monitor displays your driving settings in real time on the R-LINK2 screen.

It is a dedicated telemetry tool that controls and measures your car's performance. Functions include: a lap timer, with memory function; performance data, such as acceleration times; transverse and longitudinal g-force; data for the main engine functions, including oil temperature and brakes plus real-time engine performance data (torque, power etc). You control all the settings of your vehicle, and you can save them too.

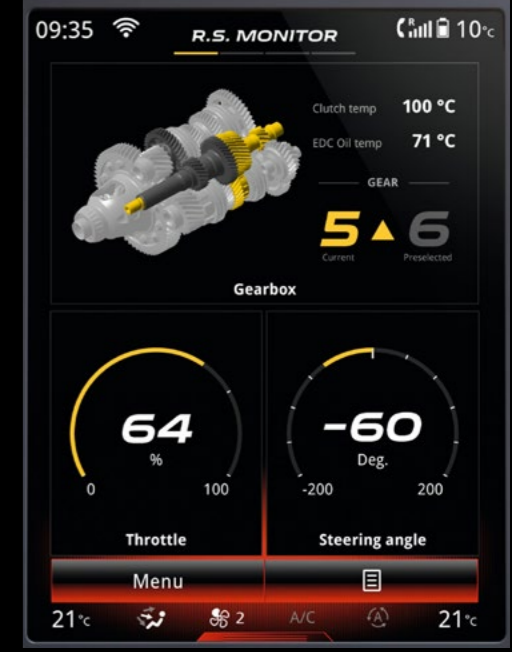
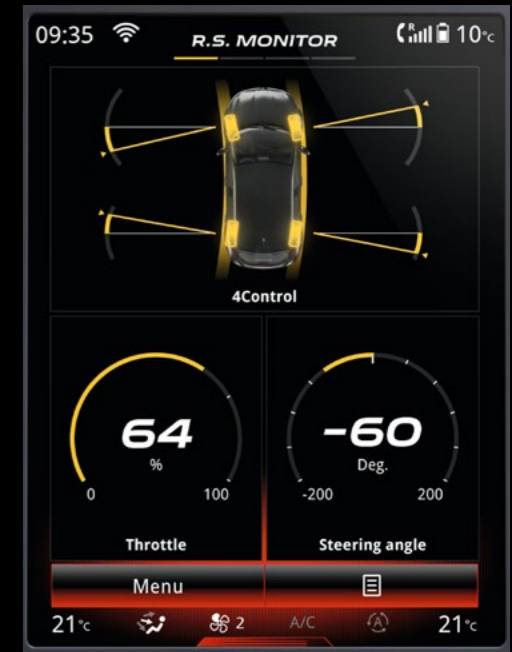



Aim for pole position

When you hit the track use R.S. Drive to select your driving mode (Neutral, Sport and Race) and adapt the gearbox mapping*, ESP behaviour, steering weight and throttle pedal mapping. Play with the paddles to change gears at ultra-fast speed.

Enjoy the excitement of a Grand Prix start with Launch Control*.

*Only on EDC version.



Launch control







Cornering & Fog light

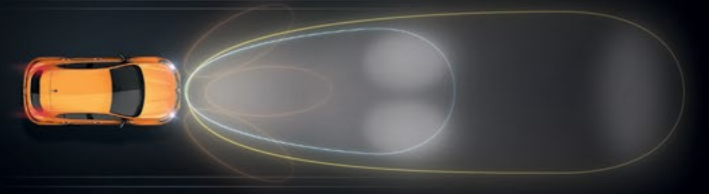

Hi-Beam

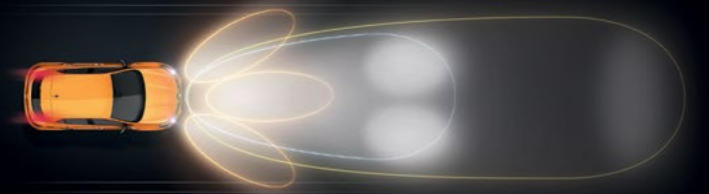

Hi-Beam & Fog



Sporty but reliable

With its many driving aids, the New Renault MEGANE R.S. allies sporting performance with safety. It also features parking sensors, overspeed warning and emergency braking assistance. An impressive pedigree!

R.S. Vision: groups the side lights, long-range headlights, fog lights and cornering lights, as part of a high-performance lighting package.



Chromo zone



TONIC ORANGE
(SMP)



SIRIUS YELLOW
(SMP)



FLAME RED
(MP)



COMET GREY
(MP)



MERCURY SILVER
(MP)



GLACIER WHITE
(NM)

NM: Clearcoat Opaque
MP: Metallic Paint
SMP: Special Metallic Paint

Note: Printing limitations do not permit subtle paint shades to be shown with complete accuracy.



Wheels

ESTORIL GUN METAL GREY



INTERLAGOS DIAMOND-EFFECT BLACK



ESTORIL GUN METAL GREY 18"

INTERLAGOS DIAMOND-EFFECT BLACK 19"

	R.S. 280 LUX	R.S. 280 CUP
ESTORIL GUN METAL GREY 18"	•	-
INTERLAGOS DIAMOND-EFFECT BLACK 19"	◦	•

Standard • Not Available - Optional ◦

Features and images may vary and be optional depending on model, and are subject to change without notice.



Creative workshop



R.S. 280 LUX EDC



Exterior Design

- R.S. extended front wheel arches with air grilles and Renault Sport marking
- R.S. extended rear wheel arches
- Custom front bumper widened with F1® Gun Metal Gray blade, honeycomb front grille with R.S. marking
- Custom rear bumper widened with functional diffuser and central exhaust
- R.S. sills/skirt with flat bottom effect
- R.S. rear spoiler
- Estoril Gun Metal Grey 18" Wheel Rims
- R.S. VISION Full LED 3 function headlights (fog, cornering, long range)
- PURE VISION Full LED front headlights with integrated C-Shape turn signal
- Starry Black door mirrors
- New R.S. back signature

Interior

- Custom R.S. black harmony roof ceiling
- Chrome-plated Renault Sport front door sills
- Front and rear door panel ambient lighting
- Aluminium pedal unit and footrest
- Alcantara R.S. upholstery and red contrast stitching
- R.S. sports seats with integrated headrests

- R.S. Nappa perforated leather steering wheel and gear lever knob with R.S. airbag cover
- R.S. dashboard and doors moulding

Safety

- Driver and passenger adaptive front airbags (passenger airbag can be disabled)
- Pelvis/thorax side airbags for driver and front-seat passenger
- Front and rear curtain head airbags
- Electronic stability control (ESC) and ABS with emergency brake assist
- LED indicators integrated into the door mirrors
- ISOFIX fastening system in rear side seats
- Tyre pressure monitoring system

Comfort and Convenience

- Rear parking sensors
- Cruise control / speed limiter
- Rain and light sensors
- Hands-free Renault card with remote locking
- Dual-zone automatic heating and air conditioning system with toxicity sensor and air recycling
- Electric, fold-in heated, demisting door mirrors
- Heated front seats

- Driver's seat with lumbar adjustment
- Height-adjustable driver and passenger seats
- 1/3-2/3 folding rear bench seat

Multimedia and Technology

- 7" Digital dash display
- 8.7" Multimedia touchscreen, South African mapping, FM/AM tuner, Bluetooth® audio streaming and hands-free calls, USB and AUX sockets, voice control, vehicle applications
- Arkamys 3D Sound 4 X 35W Radio with Bluetooth® and USB connection

Renault Sport Technology

- 4CONTROL 4-wheel steering system
- Sport chassis with 4 hydraulic compression stops
- EDC Auto Gearbox with Launch Control
- R.S. Drive activation button
- Renault MULTI-SENSE (choice of driving modes - 5 driving modes including Race mode)
- R.S. Monitor 2.0

Options

- Metallic paint
- Interlagos Black and Diamond Cut 19" Wheel Rims

R.S. 280 CUP



R.S. 280 CUP = LUX +

Exterior Design

- Interlagos Black and Diamond Cut 19" Wheel Rims

Renault Sport Technology

- Renault Sport CUP chassis with 4 hydraulic compression stops
- 6-Speed manual gearbox
- Torsen® limited slip differential
- Red brake calipers
- Custom springs/shock absorbers

Options

- Metallic paint



Freewheel: Vehicle specifications



ENGINE	MEGANE R.S. 280 LUX EDC	MEGANE R.S. 280 CUP
Fuel	Unleaded	Unleaded
Emission control level	Euro 6	Euro 6
Engine type	Turbo/direct injection	Turbo/direct injection
Capacity (cm ³)	1,798	1,798
Number of cylinders/valves	4/16	4/16
Bore/Stroke	79,7 x 90,1	79,7 x 90,1
Max. power (kW)	205	205
Max. power rating (rpm)	6,000	6,000
Peak torque (Nm)	390	390
Peak torque rating (rpm)	2,400 - 4,500	2,400 - 4,500
Stop & Start and energy recovery from braking	Standard	Standard
GEARBOX		
Type	EDC Automatic Double Clutch	Manual
Number of gears	6	6
BRAKES		
ABS + EBA + EBD + ESC	Standard	Standard
STEERING		
Power steering type	Electric power-assisted steering	Electric power-assisted steering
Steering system	R-EPS mechanical steering system	R-EPS mechanical steering system
WHEELS AND TYRES		
Wheel and tyre size	18": 235 / 40R18	19": 245 / 35R19
PERFORMANCE		
Top speed (km/h)	250	255
0 - 100 km/h (s)	5,8	5,8
0 - 400m sprint (s)	14,0	14,0
0 - 1000m sprint (s)	25,0	25,0
CONSUMPTION AND EMISSIONS*		
Urban cycle (L/100km)	8,5	9,1
Extra Urban cycle (L/100km)	6,1	6,1
Combined cycle (L/100km)	7,0	7,2
Emissions CO ₂ mixed cycle (g/km)	158	163
Fuel tank capacity (L)	50	50
WEIGHT(KG)		
Tare weight (excluding driver)	1,452	1,429
Gross vehicle mass (GVM)	1,948	1,923
Gross combined mass (GCM)	1,948	1,923
Max. braked trailer (within the GVM limit)	N/A	N/A

* Fuel consumption and CO₂ emissions are certified using a standard, regulated method. It is identical for all manufacturers and allows vehicles to be compared. Fuel consumption in actual usage depends on the vehicle's usage conditions and equipment and the driver's driving style.



Equipment & options

	MEGANE R.S. 280 LUX EDC	MEGANE R.S. 280 CUP
SAFETY		
ABS + EBD + EBA + ESP + ASR	•	•
Driver and passenger adaptive front airbags	•	•
Pelvis/thorax side airbags for driver and front-seat passenger	•	•
Airbags - Deactivation of front passenger (for use with child seats)	•	•
Airbags - Curtain front and rear	•	•
LED indicators integrated into the door mirrors	•	•
Auto locking with speed sensing door lock	•	•
Hill Start Assist (HSA)	•	•
ISOFIX child seat anchorage points on rear outer seats	•	•
Superlocking	•	•
Seats - height adjustable front seatbelts with double pretensioners	•	•
Tyre Pressure Monitor	•	•
Tyre inflation kit	•	•
EXTERIOR DESIGN		
Metallic paint	◦	◦
Special Metallic Sport Paint	◦	◦
R.S. extended front wheel arches with air grilles and Renault Sport marking	•	•
R.S. extended rear wheel arches	•	•
Custom front bumper widened with F1 Gun Metal Gray blade, honeycomb front grille with R.S. marking	•	•
Custom rear bumper widened with functional diffuser and central exhaust	•	•
R.S. sills/skirt with flat bottom effect	•	•
R.S. rear spoiler	•	•
Estoril Gun Metal Grey 18" Wheel Rims	•	-
Interlagos Black and Diamond Cut 19" Wheel Rims	◦	•
Rear LED 3D Edge Light daytime running lights, always on	•	•
Daytime running lights with LED light guides and 3D effect	•	•
Welcome sequence when approaching vehicle with brand lighting, ground lighting and light ambience	•	•
Starry Black door mirrors	•	•
New R.S. back signature	•	•
INTERIOR DESIGN		
R.S. Nappa perforated leather steering wheel and gear lever	•	•
Custom R.S. black harmony roof ceiling	•	•
Chrome-plated Renault Sport front door sills	•	•
Front and rear door panel ambient lighting	•	•
Aluminium pedal unit and footrest	•	•
Alcantara R.S. upholstery and red contrast stitching	•	•
R.S. sports seats with integrated headrests	•	•
High centre console with cup holder and closure flap	•	•
INTERIOR - DASHBOARD		
R.S. dashboard and doors moulding	•	•
Daylight/nightlight rearview mirror	•	•
Display - Digital speedometer (7" TFT screen)	-	•
Driver and passenger seat belt undone warning audible alert	•	•
Rear seat belt undone audible alert	•	•
Onboard computer	•	•
VISIBILITY, LIGHTS, REARVIEW MIRRORS, WINDOWS		
Automatic lights and wipers	•	•
Electrically adjustable, heated and folding door mirrors	•	•

Standard • Not Available - Optional ◦



	MEGANE R.S. 280 LUX EDC	MEGANE R.S. 280 CUP
Electrochrome interior rear-view mirror	•	•
R.S. VISION Full LED 3 function headlights (fog, cornering, long range)	•	•
PURE VISION Full LED front headlights with integrated C-Shape turn signal	•	•
INTERIOR LIGHTING		
Illuminated luggage compartment (on opening of boot)	•	•
Interior courtesy light controlled by all 4 doors	•	•
MULTI-SENSE system with ambient lighting	•	•
Front and rear LED ceiling lights	•	•
COMFORT		
Power-assisted steering	•	•
Steering wheel - Rake and reach adjustable	•	•
Front central armrest	•	•
Cruise control / speed limiter	•	•
Hands free keyless system with walk-away locking	•	•
Electric one touch windows, front and rear	•	•
Dual-zone automatic heating and air conditioning system with toxicity sensor and air recycling	•	•
Heated front seats	•	•
Driver's seat with lumbar adjustment	•	•
Height-adjustable driver and passenger seats	•	•
1/3-2/3 folding rear bench seat	•	•
Park sensors and rearview camera	•	•
Satellite radio controls under steering wheel	•	•
Electronic handbrake	•	-
Manual Handbrake	-	•
MULTIMEDIA AND SMART TECHNOLOGY		
7" Digital dash display with colour matrix and R.S. custom display	•	•
8.7" Multimedia touchscreen, South African mapping, FM/AM tuner, Bluetooth® audio streaming and hands-free calls, USB and AUX sockets, voice control, vehicle applications	•	•
Arkamys 3D Sound 4 X 35W Radio with Bluetooth® and USB connection	•	•
RENAULT SPORT TECHNOLOGY		
4CONTROL 4-wheel steering system	•	•
EDC - Dual Clutch Auto Gearbox with Launch Control	•	-
Sport chassis with 4 hydraulic compression stops	•	-
CUP chassis with 4 hydraulic compression stops, including Torsen® limited slip differential, red brake calipers, custom springs/shock absorbers	-	•
R.S. Drive activation button	•	•
Multi-Change Down (advanced downshift system)	•	-
Aluminium steering wheel paddles	•	-
Renault MULTI-SENSE (choice of driving modes - 5 driving modes including Race mode)	•	•
R.S. Monitor 2.0	•	•
WARRANTY & SERVICE		
5 Year / 150 000 km mechanical warranty	•	•
6 Year anti-corrosion warranty	•	•
10 000 km service intervals	•	•
5 Year / 90 000 km service plan	•	•

Standard • Not Available - Optional ◦



Dimensions

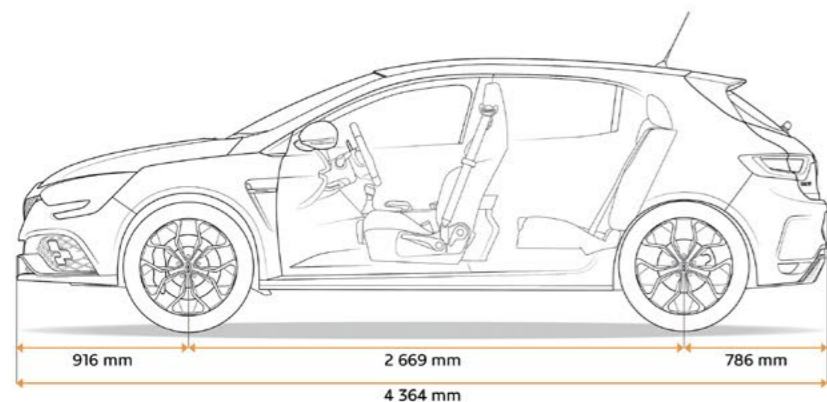

1 435 mm / 1 428 mm*

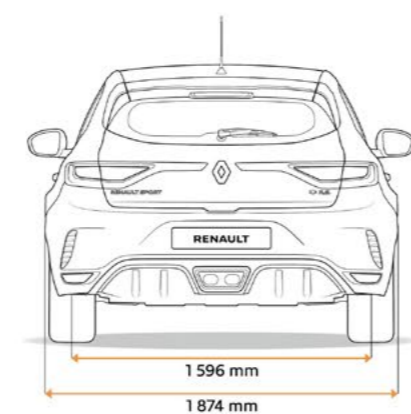
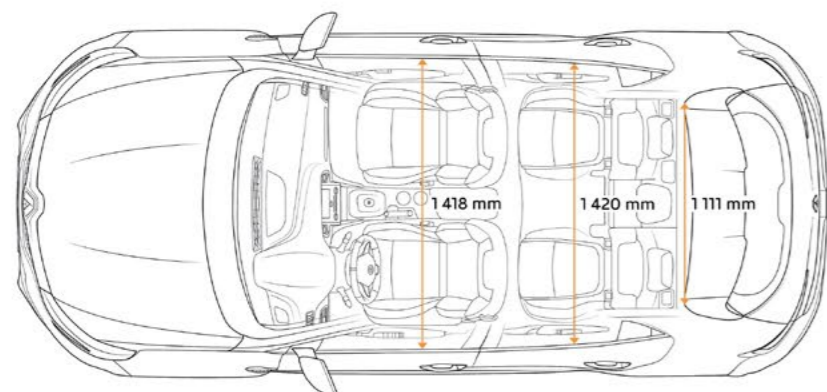
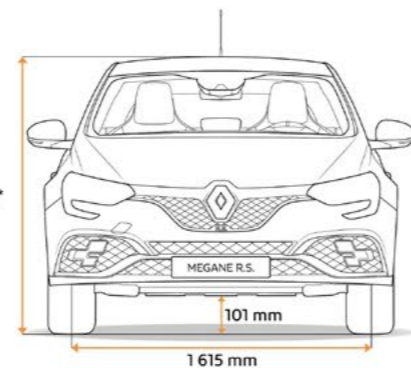

* Châssis sport / Châssis cup



The Renault Promise

MyRenault

MyRenault has been designed to make your life a little easier. Manage your vehicle online and take advantage of a range of specially tailored offers and benefits.

Register now: www.myrenault.co.za

Parts Availability

Whatever parts you need, should we not have them, we'll offer you a mobility solution. Renault ranks amongst South Africa's motor industry leaders in affordable parts pricing. Parts availability is ensured in Renault dealerships, but should your Renault become immobilised through spare parts being unavailable, you will be offered a mobility solution.

5 Year / 150 000km Warranty

With a 5 year / 150 000km warranty*, you're always covered. Should you experience any mechanical failure resulting from a defect in an original part(s) on your new Renault vehicle, Renault will cover the cost of repairs for a period of 5 years or 150 000km.

Service / Maintenance Plans

We offer standard or tailor-made options to suit your needs.

Service Plan

Having a Service Plan reduces the costs of servicing your new car. The price of the Service Plan is fixed when you buy your car, so you won't have to worry about inflationary price increases on labour or parts; for the duration of your Service Plan.

Maintenance Plan

Upgrade to a full Maintenance Plan, a comprehensive package that not only covers all your service, maintenance and labour costs over a contract period, but also gives you greater peace of mind.

24hr Roadside Assistance

Whatever the emergency, we'll always be there. Because your personal safety is of utmost importance to us, help is one phone call away. Simply dial 0861 736 2858 for assistance or for a team to be dispatched to you. Our 24 hour Roadside Assistance Plan covers all new Renault vehicles for a period of 5 years or 150 000km with an option for extension.

*Warranty does not cover wear and tear items such as shock absorbers, brake pads, clutch, cam belt, etc.



Contacts to Remember

Customer Care / Renault Assist:
0861 RENAULT (0861 736 2858)

Renault on the web:
www.renault.co.za

Experience the New Megane R.S.
at www.renault.co.za

 **R.S.**

Renault Customer Care Direct Line: 0861 RENAULT or 0861 736 2858

Renault South Africa (Pty) Ltd. reserves the right to modify its models without notice, likewise their characteristics, equipment and accessories.

Renault recommends 

5
YEAR WARRANTY
150 000 KM