

RENAULT ESPACE



DRIVE THE CHANGE



WHO BETTER THAN RENAULT TO SERVICE YOUR RENAULT?

Your new Renault Espace is covered by a 3-year warranty package – the first 2 years of unlimited mileage Renault manufacturer warranty, followed by a further year of cover up to 60,000 miles. Paintwork is also guaranteed for 3 years while the anti-corrosion warranty runs for 12 years. In addition, the Renault Assistance plan ensures prompt help in the UK and Northern Ireland for manufacturer defects for 36 months. For full details please refer to the Renault warranty terms and conditions, available from your Renault Dealer or from www.renault.co.uk.

SERVICE INTERVALS (Euro5)

All models 18,000 miles / 2 years Except:

12,500 miles / 2 years: <ul style="list-style-type: none">• Twingo 1.2 TCe 100 & Renaultsport 133• Mégane Renaultsport 250	18,000 miles / 1 year: <ul style="list-style-type: none">• Espace IV
12,000 miles / 2 years: <ul style="list-style-type: none">• Wind Roadster, Modus, Grand Modus & Clio 1.2 TCe 100 & 1.6 VVT 133• Clio Renaultsport 200	

Service required at the mileage or time interval shown, whichever is sooner.

ENGINES WITH OIL CONTROL SYSTEM (OCS)

- PETROL 1.2 TCe 100, 1.4 TCe 130, 16V 105 Auto, 2.0 TCe 180, 1.6 VVT 128, 1.6 VVT 133, Renaultsport 133 & 250

- All DIESEL engines

OCS monitors driving conditions that directly affect the quality of your engine oil, protecting your engine from excessive wear and possible bearing failure. Under certain conditions; low speeds, heavy traffic, door-to-door deliveries (engine turning with little distance travelled) or in high gear for long periods; sport driving, towing a caravan/trailer over 500kg (engine turning at higher revolutions), the vehicle's service interval may be shortened and you will be alerted, via the instrument panel service indicator, that a Renault Service is required earlier (refer to driver's handbook for details).

EXTENDING YOUR WARRANTIES AND COVER

Renault Extended Warranty allows you to extend your Renault Warranty up to 5 years or 80,000 miles. Renault Assistance Added Cover provides you with additional cover for incidents not covered by Renault Assistance: incorrect (or lack of) fuel, keys lost, stolen or locked inside the vehicle and incidents involving caravans or trailers. For full information on these products please ask your Renault Dealer or log on to www.renault.co.uk and click on 'Owner Services', where you can also buy securely online.

SERVICE PLANS

When you buy a new car, you can also purchase a Fixed Price Service Plan. Prices start from just £199 and the plan covers your recommended manufacturer servicing up to 3 years or 30,000 miles, whichever comes first.* For more details ask your dealer or log on to www.renault.co.uk and click on 'Owner Services'.

*Plan only available at the time of vehicle purchase.

RENAULT ACCIDENT SUPPORT LINE - 0800 085 8005

The Renault Accident Support Line (RASL) is a dedicated service from Renault for all Renault drivers and their families, no matter what car they drive. This service is available at no cost to you, regardless of fault. RASL will deal with every aspect of your claim, from ensuring you are recovered to a Renault Approved Accident Repair Centre to dealing with all insurance companies giving you total convenience and peace of mind. 0800 085 8005 is the only number you need so please programme it into your phone and make sure that in the event of an accident you call us first and we will take care of everything.

RASL WILL:

- Arrange recovery of your vehicle from the scene of the accident to a Renault Approved Accident Repair Centre
- Organise the repairs at a Renault Approved Accident Repair Centre using only Renault Original Parts
- Deal with all insurance companies, both yours and the other parties'
- Provide a like for like replacement vehicle if the accident is not your fault
- Pursue the at fault party for all associated costs if the accident is not your fault
- Use the same paint as during manufacture
- Provide a 5 year repair guarantee on paint and repairs
- Ensure you do not have to pay a policy excess if the accident is not your fault
- Provide the same service for your family free of charge regardless if their car is a Renault or not
- Ensure that yours and your passengers' safety are guaranteed and your five star NCAP rating will not be compromised

FINANCE OPTIONS

There are a wide variety of ways in which the purchase of a new car can be financed. Renault Finance offers all of them, so whether you're a fleet buyer or a private buyer, Renault Finance is ideally placed to tell you which plan or combination of plans best suits your needs and circumstances.

RENAULT NETWORK SERVICES

No-one is better placed than Renault to maintain, fit and repair your Renault, fast. The Renault Minute (maintenance and repair with no appointment necessary) and Renault Rapide Bodycare (bumper scuffs, dings and dents, windscreen, stone chips and interior repairs...) services deliver the highest level of repair and maintenance and offer a full year's guarantee on Original Renault Parts. And don't forget to have a look at our wide range of additional equipment and accessories!

RENAULT INSURANCE

A car as well designed as your Renault deserves an insurance policy to match. Renault Insurance has been specifically created to provide superb protection for you and your car. In addition to a very competitive premium, Renault Insurance also includes: Renault Genuine parts fitted in Renault Accident Repair Centres, protecting your 12 year anti-corrosion warranty; repairs guaranteed for 3 years; a courtesy car for the duration of any repairs subject to availability when you use an approved repairer; payment by instalments - subject to status.

Lines open 8am – 8pm weekdays, 9am – 5pm Saturdays and 10am – 3pm Sundays. Calls may be recorded. All quotes are based on individual circumstance and subject to insurers underwriting criteria. Renault Insurance is arranged and administered by Equity Direct Broking Limited, which is authorised and regulated by Registered in England & Wales No. 6710272

† 100,000 miles for Laguna and Espace

CUSTOMER RELATIONS

Renault knows the value of communicating with its customers and we have established effective ways to keep in touch with you. If after speaking to your local Renault dealership you are not completely satisfied, please contact the Renault UK Customer Relations Department on **08000 72 33 72** (Mon-Fri 9.00am to 5.30pm). You can also visit our website **www.renault.co.uk** Or write to us at: **Renault UK Ltd, The Rivers Office Park, Denham Way, Maple Cross, Rickmansworth, Hertfordshire, WD3 9YS.**

Find out more about your vehicle at www.e-guide.renault.com



WHY RENAULT? WE'RE DRIVEN BY A PASSION TO MEET AND EXCEED PEOPLE'S NEEDS, AND THAT'S WHAT DRIVES THE INDUSTRY FORWARD. IT'S BEEN THAT WAY WITH US FOR OVER A HUNDRED YEARS. BUT IN TODAY'S RAPIDLY-CHANGING ENVIRONMENT, IT'S MORE IMPORTANT THAN EVER THAT WE SOURCE NEW SOLUTIONS THAT WILL SAFEGUARD ALL OUR FUTURES.

We know that the car is at a turning point, it has to evolve whether you believe in global warming or not; to emit less in cities, to make less noise and to use increasingly scarce energy more efficiently.

At Renault we are working to create more affordable cars, with radically lower CO₂ emissions. For the widest possible audience. Today that's our collection of 'eco²' models. eco² indicates that the vehicle produces CO₂ emissions lower than 140 g/km, it includes at least 5% recycled plastic in its plastic mass, and has been designed in such a way that 95% of the materials used could have a second life (recyclable for other use or as a source of energy). In addition eco² means that our factories are ISO 14001 certified.

Starting this year there will be a groundbreaking range of electric vehicles, from a nippy town car to a comfortable family saloon and a small van. They will be affordable to run – you will be able to drive up to 100 miles using a battery that costs typically £3 to charge, and a lot less using cheaper tariffs. And parking and congestion charges should all be lower, too.

We believe it's time to make the car a driver of progress once more. We are determined to drive that change. Soon you will be able to join us.

RENAULT. DRIVE THE CHANGE.





**DISCOVER THE RENAULT ESPACE.
ITS VAST PANORAMIC ROOF
COVERS A HUGE INTERIOR.
LUXURIOUS AND INNOVATIVE,
ADAPTABLE AND BRIGHT.
ESPACE – SPACE AND COMFORT
FOR ALL.**



A PANORAMIC ROOF AND SPACIOUS INTERIOR



In the Renault Espace, the roof opens wide, allowing plenty of light into the interior. And inside, the car adjusts to meet your needs. As comfortable as they are practical, the sliding seats with automatic locking offer multiple combinations: each rear passenger can choose the position of their seat. Want to offer more seats to your many passengers? Need space for a large load? No problem – you can increase or reduce the number of seats, from two to seven, with complete ease. Day trips, daily trips...
The Renault Espace adapts to your lifestyle.

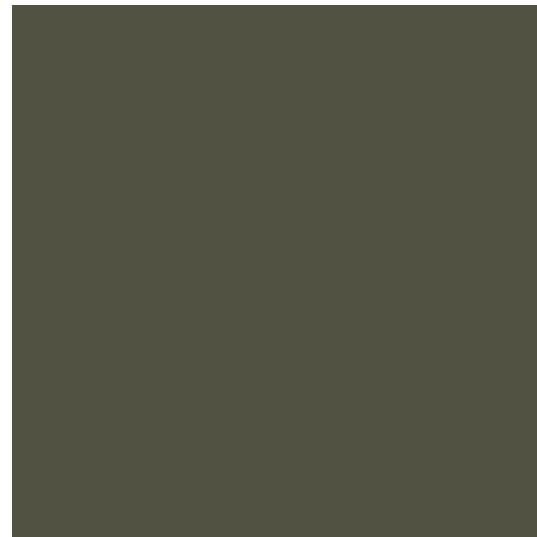

PRACTICAL TECHNOLOGY



Spacious and bright, the interior of the Renault Espace has the finest materials. On the Dynamique TomTom model for example, you'll find contoured wrap-around seats, a gloss black finish and a leather steering wheel with four spokes. The upholstery has been improved by treating it with Teflon® for reinforced protection of the seats. For the driver, all the controls are within easy reach. The intuitive joystick lets you navigate through the multimedia functions, such as the premium Arkamys® car stereo and the new Carminat TomTom® Live navigation system. Easy to use, the system offers detailed and accurate maps on a large display (5.8", or 15 cm), speed camera alerts⁽¹⁾, speed limits, points of interest and easy updates from the TomTom® Home application. In addition, by opting for LIVE Services, you'll benefit from high definition traffic information and mobile speed camera alerts⁽²⁾ in real time. The integrated system, with a colour screen, also controls the audio and Bluetooth® hands-free telephone functions. In the back, children won't notice time flying by, thanks to the DVD screens⁽³⁾ that allow them to watch films or to use their games consoles. For easy and enjoyable journeys, the Renault Espace is always connected!

⁽¹⁾ Depending on local regulations
⁽²⁾ Depending on geographical coverage
⁽³⁾ Optional



REDISCOVER THE PLEASURE OF DRIVING



The Renault Espace offers exceptional safety and performance, and the range of 2.0 dCi engines contributes to real driving pleasure. Available in 150 hp and 175 hp Euro 5 versions with particle filter (FAP), this engine offers exceptional performance and fuel efficiency. Economical, quiet and environmentally friendly, it impresses with its high torque, available over a very wide range, combining flexibility with liveliness. For everyone's safety, the Renault Espace offers a combination of active and passive safety devices. This high level of protection is illustrated by the 5 star score in the Euro NCAP crash tests.



SECURITY

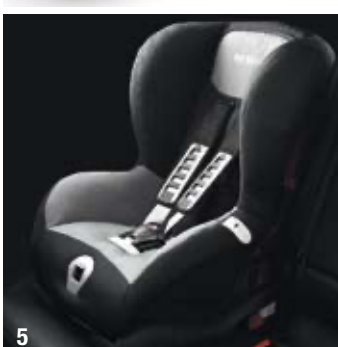
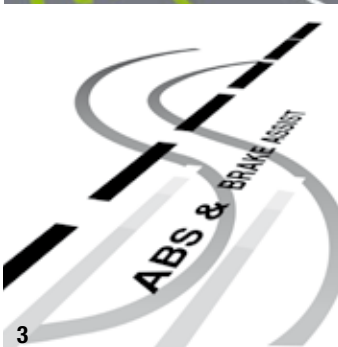

1. LED HEADLIGHTS

The Renault Espace now offers LED technology in its headlights. The DRL (Daytime Running Light) system keeps the LEDs permanently lit to guarantee an optimal visual presence for other drivers and pedestrians, by day and by night.

2. DYNAMIC ESC (ELECTRONIC STABILITY CONTROL) DRIVING CONTROL

The ASR traction control and CSV understeer control ensure the vehicle's stability, especially in difficult road conditions.

3. ABS

The ABS wheel Anti Blocking System, with EBD (Electronic Brake Distribution) linked to the Brake Assist, helps to maintain control over direction when braking hard.

4. AIRBAGS

Two adjustable front airbags. Two head curtain airbags. Four side thorax airbags front and rear.

5. ISOFIX SYSTEM

The rear seating is equipped with Isofix for attaching child seats in safety. The fasteners are easy to access and the system is simple to use.

ADAPTABILITY / STORAGE

1. CENTRE STORAGE CONSOLE

The centre console offers multiple large-capacity storage options that are both ergonomic and practical.

2. UPPER-LEVEL STORAGE

Integrated in the dashboard on the driver and passenger sides.

3. AVIATION STYLE SEAT TABLES

Fitted to the back of the front seats, with cup holder.

4. TWO TO SEVEN SEAT MODULARITY

Travelling as a family or with large loads... take out or move three, four or five rear seats.



ACCESSORIES

PROTECTION AND COMFORT

Keep you and your Renault safe and sound.

Protection and safety are number one priorities for Renault. Renault Accessories has developed a range of products that will help keep you and your car in complete safety.

1. MATS

Mats are an essential accessory to protect your car from everyday dirt and debris. Designed to fit perfectly into your Espace, the inbuilt stud fixings ensure they fit safely with no slipping.

2. CHILD SEATS

Children are most vulnerable, so their safety is of the highest importance to Renault. Your Espace is equipped to fit ISOFIX child seats so you can relax knowing that your children are secure and comfortable in their Duo Plus seat, watching the world go by.

3. COOLER

Fixed on rails, it lets you keep food and drink cool on those trips away.

4. BOOT DIVIDER

The aluminium boot divider with retractable compartments helps keep everything in its place.

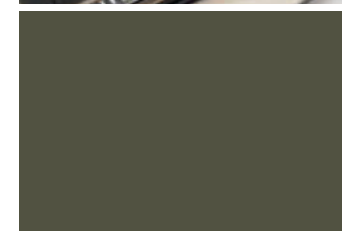

TOURING

You, your Renault and the kitchen sink. Planning ahead to your holidays?

Renault Accessories has developed a range of accessories to maximise the load carrying capacity of your Espace. If the boot space is not enough, take a look at our towing and roof accessories.

5. ROOF BARS, SKI RACK, BIKE RACK

Whether you are planning a ski trip or just a day out with the bikes, we have an accessory for you. Our bike racks can be mounted on the roof or a tow bar. They are City Crash tested to ensure maximum safety and security.

6. ROOF BOX

Going on holiday and need to pack the kitchen sink? Our range of Touring Line roof boxes are the ideal way of increasing your boot space. They are lockable and are designed to perfectly fit the Renault Touring Line Roof Bars.

7. TOW BAR

Whether you need to pull a trailer, a caravan or simply mount one of our bike racks, Renault has the tow bar for you.

TECHNOLOGY

Cutting edge technology in your Renault.

8. DVD SYSTEM

"Are we nearly there yet?" Boredom on long journeys is a thing of the past with our DVD player. Mounted onto the back of the headrest, it provides hours of entertainment for the rear passengers. Comes with two screens and infra red headphones.

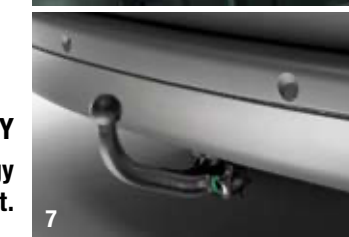
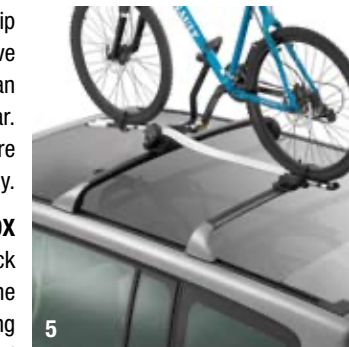

TRIMS



DYNAMIQUE TOMTOM

Leather steering wheel, high gloss piano black dashboard and centre console trims and sporty upholstery (treated with Teflon for extra protection). The Espace Dynamique TomTom's interior is both modern and comfortable.



INITIALE LUX PACK

Full leather Riviera upholstery and high gloss piano black trims come as standard if you opt for the Initiale Lux Pack. This elegance goes hand in hand with the high quality modern technology - Arkamys stereo and Carminat TomTom system.



CORE FEATURES

SAFETY AND SECURITY

- ABS with EBD (Electronic Brake Distribution)
- ASR (traction control)
- Brake Assist
- CSV (understeer control)
- Deadlocking and engine immobiliser
- Driver and front passenger two stage auto-adaptative airbags
- Driver, passenger and rear seatbelts with pretensioners
- ESC (Electronic Stability Control)
- Front passenger airbag deactivation switch
- Front lateral airbags
- Front and rear curtain airbags
- Insurance approved engine immobiliser (Thatcham category 2)
- Insurance approved alarm (Thatcham category 1)
- Integrated headrests on all vehicle seats
- ISOFIX child seat mounting points on all rear seats
- R.A.I.D. (Renault Anti Intruder Device) automatic door locking
- 'See me Home' headlights

COMFORT, DRIVING AND VERSATILITY

- Double optic headlamps
- Electric front and rear windows
- Front fog lights
- Height adjustable driver's seat with lumbar support
- Height and reach adjustable steering wheel
- Keyless car with Renault card
- Height and reach adjustable steering wheel
- LED daytime running lights
- Power steering
- Remote control central locking
- Tinted windows
- Trip Computer
- Tyre inflation kit

STANDARD EQUIPMENT

DYNAMIQUE TOMTOM

Additional Equipment to Core Features

- 4x20W Single CD / radio MP3 with Bluetooth connectivity and fingertip control
- 7 individual seats
- Alloy wheels - 17" Eptius with a 'dark metallic GT finish'
- Automatic headlights
- Automatic rain sensitive windscreen wipers

- AUX input
- Carminat TomTom Live navigation system
- Carpet mats - rows 1 and 2
- Cruise control
- Dual-zone Climate control
- Door mirrors - pearl black, electric folding and heated
- Keycard - hands free
- Parking sensors - rear

- Roof bars / rear roof spoiler
- Parking sensors - rear
- Speed limiter
- Steering wheel - leather
- Sunblinds - 6 rear windows
- Upholstery - Dark Carbon sport style with TEFLON protection
- Windows - extra tinted rear and tailgate
- Windscreen - heat reflecting

COLOURS



GLACIER WHITE PEARL BLACK MERCURY ECLIPSE GREY STONE PEARL BLUE

	Glacier White	Pearl Black	Mercury	Eclipse grey	Stone	Pearl Blue
	OV	NV	TE	TE	TE	TE
	369	676	D69	B66	HNK	RNY

DYNAMIQUE TOMTOM

INITIALE LUX PACK

OV = Non Metallic Super Gloss NV = Metallic Pearlescent TE = Metallic Illusion
 ● = Standard ○ = Option

WHEELS



17" 'EPTIUS' DARK METALLIC ALLOY WHEELS
Standard on Dynamique TomTom

17" 'NOVADIS' ALLOY WHEELS
Standard with Initiale Lux Pack

DIMENSIONS

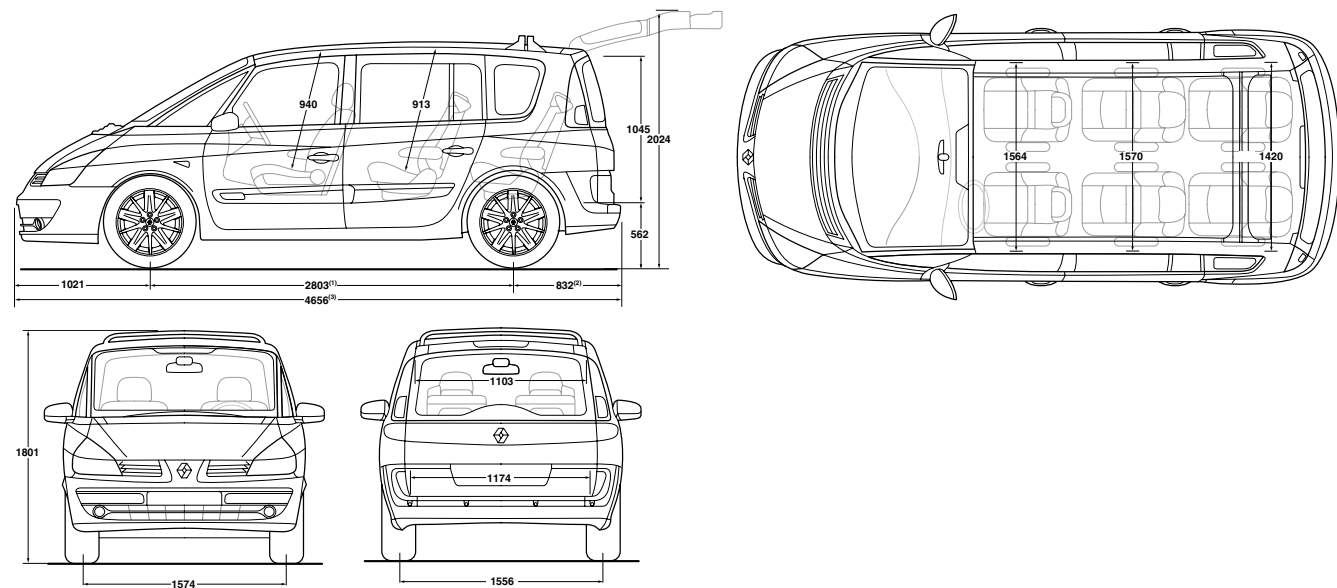

For Grand Espace : (1) 2868 ; (2) 967 ; (3) 4856

TECHNICAL SPECIFICATIONS

	2.0 dCi 150 FAP	2.0 dCi 175 Auto FAP
ENGINE		
TYPE MINES		
Espace	JK1HA6	JK1KAC
Grand Espace	JK1JC6	JK1KCC
ENGINE CHARACTERISTICS		
Emissions conformance	Euro 5	Euro 5
Engine type	M9Rk 814	M9Rk 815
With particulate filter (FAP)	FAP	FAP
Induction capacity	1995	1995
Bore x stroke	(mm) 84 x 90	84 x 90
Compression ratio	16:01	16:01
Maximum power	(kw ISO) 110	127
Maximum power	(hp DIN) 150	175
Maximum power	(rpm) 4000	3750
Maximum torque	(Nm ISO) 340	360
Maximum torque	(rpm) 2000	1750
Fuel type	Diesel	Diesel
Injection type	Commonrail Direct Injection	Commonrail Direct Injection
Number of cylinders	4	4
Number of valves	16	16
WEIGHTS		
Max. (Driver Only) Towing Weight Braked	(kg) 2000 / 2000 (lb) 4409 / 4409	2000 / 2000 4409 / 4409
Kerb weight	(kg) 1901 / 1931 (lb) 4190 / 4257	1933 / 1963 4262 / 4328
Gross vehicle weight	(kg) 2605 / 2620 (lb) 5743 / 5776	2640 / 2665 5820 / 5875
Maximum gross train weight	(kg) 4105 / 4120 (lb) 9050 / 9083	4140 / 4165 9127 / 9182
GEARBOX		
Number of forward gears	6	6
Manual / Automatic	Manual	Automatic
Vehicle speeds (mph) @ 1,000 rpm		
1 st	(mph) 5,24	5,47
2 nd	(mph) 9,74	9,55
3 rd	(mph) 14,78	14,51
4 th	(mph) 21,01	19,78
5 th	(mph) 27,11	26,83
6 th	(mph) 32,12	33,48
BRAKING SYSTEM		
ABS with Brake Assist	Standard	Standard
Front Ø / width	(mm) 324 / 28	324 / 28
Rear Ø / width	(mm) 300 / 11	300 / 11
SUSPENSION		
Front		MacPherson strut with helical springs
Rear		Semi-fixed with longitudinal guide bars
STEERING		
Power assisted	Assisted	Variable assisted
Turning circle between kerbs / walls		
Espace	(m) 11.0 / 11.3	11.0 / 11.3
Grand Espace	(m) 11.4 / 11.8	11.4 / 11.8
WHEELS AND TYRES		
Standard wheel size	(inches) 17"	17"
Reference tyres	225 / 55 / R17 101 W	226 / 55 / R17 101 W
Spare wheel	Inflation kit	Inflation kit
CAPACITY		
Fuel tank	litres (gallons) 83 (18.26)	
PERFORMANCE		
SCx (Aerodynamic Coefficient)	0,931	0,931
0-62mph (0-100kph)	(seconds) 10,6	11,1
Maximum speed	mph (kph) 121 (194)	123 (198)
Standing qtr mile (400m)	(seconds) 17,5	18,2
Standing 1000m	(seconds) 32,3	32,5
EMISSIONS		
CO ₂	(g/km) 170	189
FUEL CONSUMPTION		
Urban Cycle	(mpg) 34,4 (litres/100km) 8,2	30,4 9,3
Extra Urban Cycle	(mpg) 49,6 (litres/100km) 5,7	46,3 6,1
Combined Cycle	(mpg) 43,5 (litres/100km) 6,5	39,2 7,2
SERVICING INTERVALS*		
Oil change interval in miles / 2 years (whichever is the sooner)	18 000	18 000

* Service interval may be reduced if vehicle is subject to severe usage CO₂ benefit in kind and mpg figures may vary according to optional equipment.

RENAULT eco2

Espace meets three criteria:

- It is manufactured in an ISO 14001 certified factory, minimising its environmental impact.
- The vehicle produces CO₂ emissions lower than 140g/km or operates on biofuels,
- and it includes at least 5% recycled plastic in its plastic mass.

With Renault displays its environmental commitment at every stage of the life cycle of the vehicle. The vehicle has been designed in such a way that 85% of the materials used could have a second life (recyclable for other use or as a source of energy), and that pollution control at the end of the vehicle's life (in particular extraction of fluids) is made easier.

EQUIPMENT AND OPTIONS

	DYNAMIQUE TOMTOM
SAFETY	
Active and Passive Safety Features	
ABS with EBD (Electronic Brake Distribution)	●
Brake assist	●
ESC (Electronic Stability Control)	●
ASR traction control	●
CSV understeer control	●
Driver and front passenger auto-adaptive airbags (with deactivation of front passenger airbag)	●
Curtain airbags - rows 1 and 2	●
Lateral thorax airbags - row 1	●
Audible seatbelt reminder, height adjustable seatbelts with pretensioners for driver and passenger	●
Integrated 3 point seatbelt on all rear seats	●
ISOFIX child seat mounting points on rear seats	●
Child lock control of rear windows and door from driver's side control	●
R.A.I.D. (Renault Anti Intruder Device) - automatic door locking at +4mph	●
Third high level brake light	●
See and Be Seen Visibility Features	
Twin element halogen headlights with manual headlight beam height adjustment	●
LED - daytime running lights	●
Bi-Xenon directional headlights with washers / wipers and automatic beam height correction	○ / P1
Front fog lights	●
"See me home" headlights - dipped beam time delay	●
Automatic rain sensitive front windscreen wipers	●
Automatic headlights	●
Door mirrors - electrically operated and heated; blind spot eliminating mirror on driver's side	●
Door mirrors - electrically folding, with blue-tinted glare reduction glass	●
Door mirrors - electrically operated and heated with memory function	P1
Vehicle Security	
Transponder controlled engine immobilisation system - Thatcham category 2	●
Insurance approved alarm system - Thatcham category 1	●
Deadlocking	●
Anti-theft locking wheel bolts	●
EXTERIOR FEATURES	
Exterior styling	
17" "Eptius" alloy wheels with dark metallic GT finish	●
17" "Novadis" alloy wheels	P1
Metallic paint	○ / P1
Roof bars / rear roof spoiler	●
Pearl black coloured door mirrors	●
Chrome exterior door handles	●
COMFORT AND CONVENIENCE	
Driving Technology	
4-spoke leather-bound steering wheel and leather gearknob	●
Height and reach adjustable steering wheel	●
Leather gearstick gaiter	-
Keycard - hands free	●
Parking proximity sensor - rear	●
Parking proximity sensor - front	P1
Electronic automatic parking brake	●
Power assisted steering	●
Variable power assisted steering (on dCi 175 FAP engines only)	●
Trip computer	●
Cruise control	●
Speed limiter	●
Integrated F1 style fuel filler cap	●
Tyre inflation kit	●
Emergency spare wheel	○

	DYNAMIQUE TOMTOM
Windows and Blinds	
6 rear integrated sunblinds (door windows, rear quarters and tailgate)	●
Electric front and rear windows with "anti-pinch" sensors and one-touch controls	●
Panoramic electric sunroof with electric sunblind	○
Extra-tinted glass on rear windows and tailgate (from B pillar)	●
Heat reflective windscreen	●
Heated rear windscreen	●
Opening tailgate window	○ / P1
Ventilation	
Climate control with separate driver / passenger controls, rear seat controls and heat reflective windscreen	●
14 air outlets (rows 1, 2 and 3)	●
Storage and Functional Features	
Front accessory socket/ cigarette lighter, 2 integrated cupholders, movable ashtray	●
12V accessory power sockets (front cigar lighter and rear socket of the centre console)	●
Aircraft style folding trays for row 2 passengers, with integrated cup holder	●
5 grab handles (silicon damped), and 2 vertical easy-access handle on middle pillar	●
Seating, Carpet Mats, Interior Styling	
"Slide and Lock" seating system	●
Front captain's chair, height adjustable with adjustable armrests and adjustable lumbar support on driver's seat	●
Electrically adjustable front seats with driver's memory function	P1
Heated front seats	P1
Headrests on all seats	●
Rear seats with integrated 3 point seatbelt, ISOFIX fixings, on sliding rails - all interchangeable, folding to table, and removable	●
7 individual seats	●
6 seats (6 captains chairs - replacing 7 individual)	P1
1 extra rear seat	○†
Dark Carbon sport style upholstery with TEFLON protection	●
Dark Carbon perforated leather upholstery	P1
Carpet mats rows 1 and 2	●
Carpet mat rows 1, 2 and 3	○ / P1
Interior Lighting	
Auto day / night electrochrome rear view mirror	P1
Body coloured electrochrome electrically folding door mirrors	P1
Lights: illuminated entry and boot courtesy light	●
Lighting in lower central dashboard storage area and passenger glovebox	●
Driver and front passenger sun visor with illuminated foldable mirrors	●
Storage and Functional Features	
Roof mounted control panel: central locking; hazard warning lights and main interior cabin light	●
Upper and lower (illuminated) central dashboard storage area, and 2 additional covered storage trays on upper instrument panel	●
Illuminated passenger glove box	●
Front and rear door pocket storage areas	●
Enclosed third row / boot storage compartments, with lidded storage in third row left armrest	●
Map / book pockets in front seat backs	●
Driver's sunglasses holder	●
Retractable luggage compartment cover	●
Chrome effect interior boot sill	●
Tailgate interior grab handle	●
In-car Entertainment and Communication	
Fingertip control audio system	●
4 x 20W single CD / radio MP3 with Bluetooth connectivity, AUX (RCA) input and fingertip control	●
4 x 20W single CD / radio MP3 with Bluetooth connectivity, multi-functional TunePoint and fingertip control	○ / P1
Carminat TomTom Live navigation system with joystick control	●
Carminat TomTom additional mapping - Western Europe	○ / P1
DVD system with 2 x 16.9 screens integrated into rear of the front seat headrests	○
Option Packs	
P1 - Initiale Lux pack: 17" "Novadis" alloy wheels, multi-functional TunePoint, Western Europe mapping for Carminat TomTom, row 3 carpet mats, electric folding heated door mirrors with memory, bi-Xenon headlights, metallic paint, opening tailgate window, front parking sensors, 4 rear seats with armrests, electrochrome rear view mirror, electrically adjustable / heated front seats (driver's memory) and Dark Carbon leather	○

● Standard ○ Option (stand-alone) - Not available P1 Available as part of a Pack (number denotes pack) † Must be ordered with the Initiale Lux pack

RENAULT ESPACE



(Enter Renault's world at Sky Guide 883 and www.renault.tv)

3
YEARS WARRANTY
100 000 miles

RENAULT recommends 

Although every effort has been made to ensure that the information contained within this brochure is as accurate and up to date as possible, Renault U.K. reserves the right to modify its models without notice, including their characteristics, specifications, equipment and accessories. Brochures inevitably become out of date or inaccurate in some respects, in that such characteristics, specifications, equipment, or accessories may be changed after the publication date given below and can differ from the descriptions given. It is therefore necessary to check with your Renault Dealer before purchasing any product that the characteristics, specifications, equipment or accessories of the vehicle on order are as advertised. Publication date August 2011.

