



MASERATI

GRANTURISMO/GRANCABRIO





*GranTurismo / GranCabrio*





*Maserati*

GT 100 MC





---

## TRUE TO ITS RACING TRADITION, GRANTURISMO REFUSES TO BE SURPASSED

---

Like those who retain lifelong A-list status, Maserati GranTurismo exudes a certain charisma that combines a stunning, jaw-dropping appearance with an unmistakable competitive spirit, derived from some extremely accomplished family lineage. Inspiration for GranTurismo starts with the classic Maserati A6 series that dominated tracks and roads beginning over 75 years ago. Their unmatched combination of Italian craftsmanship and groundbreaking technology is continued, creating the latest sibling in which performance is experienced to its fullest. The GranTurismo is a perfect example of Maserati's uncompromising philosophy and spirit. It combines the ideal blend of responsiveness, elegance and luxury that will satisfy the world's most enthusiastic and demanding drivers.

---

## DRIVERS OF GRANTURISMO ENJOY ADVANTAGES MADE POSSIBLE BY THE TENACIOUS DRIVERS OF TARGA FLORIO

---

Innovation has long been the cornerstone of the Maserati marque, resulting in a long history of racetrack victories, most notably at Targa Florio, the first of motorcar competitions that originated in the early 1900s. With treacherous, winding cross-country courses on rutted trails in the mountains of Sicily, Targa Florio wins were hard-fought tests of driver and vehicle endurance. The race became

a decades-long tradition, producing some of the world's most respected and enduring carmakers. Targa Florio's main lesson? Learn from the past, but always look forward: innovation must always be paramount. It's a conviction that is no doubt shared by those fortunate to drive GranTurismo — applying those same principles to their own story of success.

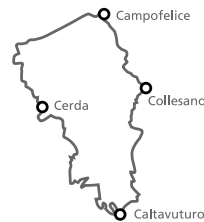

CIRCUITO DELLE MADONIE PICCOLO\_1932-1936\_1951-1977



CIRCUITO DELLE MADONIE GRANDE\_1906-1911\_1931













---

GRANCABRIO DELIVERS A LEVEL OF HIGH DESIGN AND PERFORMANCE THAT IS LAUDED BY THOSE WITH THE MOST DISCRIMINATING OF EYES

---





---

GRANCABRIO POSSESSES STRONG LINES THAT DRAW YOU  
IN AND CREATE A SOLID, UNFORGETTABLE PRESENCE

---



ITS INHERENT ATHLETICISM IS THE SOURCE OF ITS ALLURE





---

## THE LATEST IN A SERIES OF EXTRAORDINARY CHOICES

---

It was 1947. The original idea of installing a racing engine in a road-going car gave birth to the famed A6 1500 GT Pininfarina, the very first Maserati GranTurismo. Ever since then, Maserati has led the world in the production of dynamic and desirable performance cars that are exciting to drive, comfortable for everyone onboard, and featuring the very highest levels of safety. Sixty years later, the dream lives on with the Maserati GranTurismo range, comprised of the GranTurismo, GranTurismo Sport, GranTurismo MC Stradale and GranTurismo MC Stradale Centennial Edition. These cars combine prestige, elegance and immense power; they have been created for those who live life to the fullest and seek uncompromising motoring enjoyment.





---

## MASERATI GRANTURISMO A UNIQUE STYLE

---



The GranTurismo's powerful and dynamic front end is dominated by the oval radiator grille and horizontal headlamps, with LED Daytime Running Lamps (DRLs) blended perfectly into the bumpers. The V-shaped bonnet has three air intakes on each side in classic Maserati style, which lighten the long nose section and enhance the overall image of dynamism and verve. The radical sideskirts bring further drama to the car's profile. The rear end also echoes the GranTurismo's sportiness and high-tech soul: the triangular rear lamps use 96 LEDs, and a wide aerodynamic diffuser opens out over the lower part of the bumper.

---

## AN OPULENT INTERIOR

---

The GranTurismo's interior makes a similar statement of prestige and refinement: underlining its exclusivity, the marque's distinctive "V" motif runs along the top of the dashboard and then appears as a signature on various features like the door panels and quarter panels. The restrained yet charismatic detailing is exquisite: subtle chrome rings decorate the buttons on the dashboard and steering wheel, the seats are stitched to reflect the line of the radiator grille, the Trident logo is handcrafted on the seat headrests, and the trim lining on the backs of the gearchange paddles and in the storage compartments are in soft, tactile Alcantara®. These are just a few examples of the

attention to detail in which Maserati believes so strongly, and which create an overall image that never fails to impress. When sitting in the driver's seat, the first thing one notices is the three-spoke Sports steering wheel with its profiled grip. Leather-covered and extremely ergonomic, it features controls that operate many of the car's systems and promotes safe driving. These buttons control the main multimedia functions, which are then displayed on the 7-inch screen of the Maserati Multimedia System in the centre of the dashboard.





#### MASERATI GRANTURISMO ENGINE AND TRANSMISSION

---

## POWER AND PERFORMANCE

---

Compact, lightweight (just 180 kg) and quick to respond, the Maserati GranTurismo's 4.2 litre V8 delivers 405 HP at 7,100 rpm, and a maximum torque of 460 N•m at 4,750 rpm — 75% of which is available at just 2,500 rpm. This adds up to exceptional performance, with acceleration from 0 – 62 mph in just 5.2 seconds and a top speed of 177 mph. The ZF 6-speed automatic gearbox makes driving smooth and pleasurable without compromising the engine's sporty performance and offers excellent response whatever the circumstances. For those who want to exploit the power of the V8 to its fullest, it provides lightning-fast gear changes, whereas for a more relaxing drive, the gearbox adopts ratios designed to reduce fuel consumption and noise at high speeds, and offers excellent comfort over long distances.





---

## MASERATI GRANTURISMO SPORT POWERFUL CHARISMA

---



The Maserati GranTurismo Sport is the latest evolution of the Maserati coupé concept, delivering new levels of style, sophistication, handling and performance, whilst leaving comfort and drivability uncompromised. Available in two versions with either an automatic or robotic manual gearbox, the GranTurismo Sport has pushed back the frontiers in terms of power and elegance. An extraordinarily charismatic car, it has been designed to satisfy the needs and desires of the most passionate driving enthusiasts.

MASERATI GRANTURISMO SPORT EXTERIOR

---

## ELEGANCE AND PASSION

---

A single glance at the GranTurismo Sport can be guaranteed to make the heart beat faster with its ultra-dynamic looks. One of the most significant areas is the front bumper with air intakes that not only improve the flow of air and cooling of the front brakes, but also act as a stylistic junction between the traditional oval grille and the headlamps — with LED Daytime Running Lamps (DRLs) and a steel finish. The centre of the grille features the Trident symbol in chrome with Red detailing — a tradition

reserved for only the most powerful Maseratis. The central splitter comes in Black as standard or in carbon fibre as an optional extra. The rear end then boasts taillamp moldings with a special fumé finish, which accentuates the effect of the 96 LEDs. The dynamic appearance of the GranTurismo Sport is intensified by the metallic Blu Sofisticato finish, a colour which makes the bodywork even more eye-catching. The large, 20-inch Astro Design alloy wheels accentuates the sporting character of the car. Through its spokes, the powerful Brembo® brake calipers are clearly visible.





---

## ERGONOMIC SPORTS INTERIOR

---

The interior of the GranTurismo Sport is a fusion of top-class materials, expert craftsmanship, obsessive attention to detail and extensive studies in ergonomics. The design objective was to create a superlative sporting experience for the driver, whilst ensuring comfort and spaciousness for everyone else on board. The sporty nature of the GranTurismo Sport's interior is also evident in the use of Alcantara® trim and traditional Poltrona Frau® leather, along with the Dark Chrome and Eco Chrome detailing on the dashboard, door panels and quarter panels.



#### ENGINE AND TRANSMISSION

---

### HIGH PERFORMANCE AT THE CUTTING EDGE

---

The GranTurismo Sport's 4.7-litre V8 engine is an industry benchmark for high performance: up to 460 HP at 7,000 rpm. Its mechanical sophistication, which has always been a Maserati hallmark, is combined with numerous innovative features. The increase in displacement, compared to the 4.2-litre V8 of the GranTurismo, has been achieved whilst minimising the engine's weight and size. High levels of torque are delivered right up through the rev range to guarantee a smooth and responsive drive, with maximum torque peaking at 520 N•m. As a result, the GranTurismo Sport has a top speed of 186 mph and accelerates from 0 – 62 mph in 4.7 seconds. With the MC Auto Shift gearbox, it can reach a top speed of 185 mph and 0 – 62 mph in 4.8 seconds. The ZF

6-speed automatic gearbox with its hydraulic torque converter guarantees a comfortable ride with no reduction in performance. The transmission is controlled by the MC Auto Shift software, with rev limiter override, double-declutch and high-performance start function. There are five operating modes: Auto Normal, Auto Sport, Manual Normal, Manual Sport and Ice.







---

## MASERATI GRANTURISMO MC STRADALE SHARE THE THRILL

---



The GranTurismo MC Stradale represents the summit of Maserati's expertise as a manufacturer of high-performance cars. It is now even more powerful and inherits from its race sibling, the GranTurismo MC Trofeo, features and technology developed to win races on circuits all over the world. The GranTurismo MC Stradale delivers exceptional performance and handling, whilst at the same time displaying all the values of comfort and practicality typical of the GranTurismo range. The ongoing dialogue between Maserati's racing team and its road car engineers has resulted in this, the most uncompromising of all current Maseratis.



---

## CARBON TAKES SHAPE

---

The prime distinguishing feature of the GranTurismo MC Stradale is its carbon fibre bonnet, which features an aggressive central air intake and two large air vents that are modelled on those of the GranTurismo MC Trofeo racing car. In addition, the front spoiler, sidskirts and slots in the front bumper combine to keep the front of the car down at high speeds, cool the brakes, and deliver downforce to the entire car. The sidskirts have been specially designed to integrate with the vents to channel the airflow under the car's body, thus further increasing stability.

The GranTurismo MC Stradale comes in a triple-layer Grigio Lava (Pearl Grey) shade — an elegant and sporty colour with iridescent qualities. The resultant shimmering effect connects the curves of the bodywork to the numerous streamlined vents and changes colour with the light. 20-inch Trofeo Design forged alloy wheels then complete the visual drama.





#### MASERATI GRANTURISMO ENGINE AND TRANSMISSION

### A RACING CAR FEEL YOU CAN TOUCH WITH YOUR HANDS

In order to evoke a typical racing car atmosphere, the Alcantara® trim is extended to many parts of the interior, from the central console to the doors and the instrument panel brow, all of which are embellished with fine stitching. The sporty feel continues with the Nero Soft finish on the decorative elements of the dashboard, the door panels, the rear side panels and the special bezel at the base of the rear-seat headrests. Situated behind the steering wheel, and sporting a flatter rim with an improved grip, are the longer Trofeo Design gearshift paddles for maximum control over gear changes. The pedals are made of perforated aluminium to improve the feel and control of the accelerator and brake. The sporty seats with integrated headrests are designed to provide the optimum driving position, with a high level of lateral support, whilst at the same time ensuring maximum comfort. The soft Poltrona Frau® leather is combined with a race-inspired central section featuring Alcantara®. The backrest features a customisable rear shell in carbon fibre, and is finished with fine stitching around the edges that emphasises the craftsmanship of the seats. This shell designed to match the front seats provides additional leg room to those sitting in the rear seats.





18:43

16°C

N

AUTO

km  
10

km/h  
0

rpm x 1000

VOLVO

130

°C

50

ENGINE, TRANSMISSION, SUSPENSION AND BRAKES

---

## TECHNOLOGICALLY UNMATCHED

---

The unmistakable roar of the centrally positioned tailpipes emanates from Maserati's celebrated 4.7-litre V8. Found here in its most powerful incarnation, it delivers a prodigious 460 HP and 520 N•m of torque at 4,750 rpm. Sixty-two mph comes up in just 4.5 seconds and the top speed potential is an awe-inspiring 188 mph. The intense and distinctive noise is underlined by the permanent opening of the by-pass valves when in Race mode. While the GranTurismo offers five electronic transmission modes, the MC Stradale has three: Auto, Sport and the exclusive "MC Race." This setup is unique to this model, and is activated by pressing the "Race" button on the dashboard. This is all it takes to make the car even more aggressive and sporty, and the 6-speed gearbox allows lightning-fast gearshifts in just 60 milliseconds. The exclusive Brembo® carbon-ceramic brakes play a key role in the overall balance of the GranTurismo MC Stradale, guaranteeing

powerful braking that is fade-resistant even when used intensively. The setting of the MC Stradale's suspension is 10 mm lower and has been developed with the aid of racetrack technology. The springs and dampers have been stiffened to restrict lateral load transfers, whilst the stabiliser bar diameter has been increased to reduce the roll angle and gradient for optimal handling.

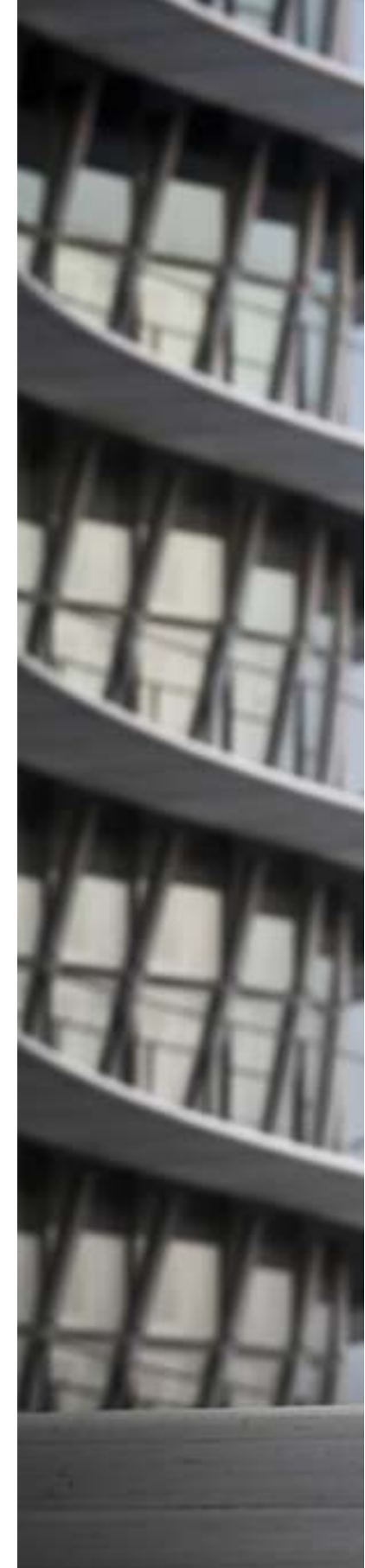







GRANTURISMO MC STRADALE CENTENNIAL EDITION

---

## A SPECIAL CELEBRATION CALLS FOR A SPECIAL MASERATI

---

It was on the first of December, 1914, that the brothers Alfieri, Ettore and Ernesto Maserati first opened their garage in the heart of Bologna. A century later, their company still stands for everything they originally believed in: passion, innovation and the eternal quest for perfection. To celebrate the marque's centennial, a very special Maserati has been created: the GranTurismo MC Stradale Centennial Edition. In true Maserati tradition, this is a car that is one of the most extreme of its type, sporting special exterior and interior finishes and trims, along with distinctive features and detailing that serve to define Maserati's mastery of automotive art. In this commemorative car, the Maserati myth continues.







---

## GRANTURISMO MC STRADALE CENTENNIAL EDITION ON THE MOVE WHILST STANDING STILL

---



The fastest and lightest car in the Maserati range is now the most visually dramatic, as well. The Rosso Magma colour reveals the car's lines in a new light, and actually manages to make it look like it is on the move even when it is standing still. This special pearlescent Red is applied in three coats, with undertones of Purple and dark Blue, and varies in colour depending on how the light strikes it. To celebrate Maserati's centennial in style, three more triple-coat colours have been created, each one matched to specific interiors: Blu Inchiostro, Grigio Pietra with mica providing an interesting metallic effect, and Bianco Birdcage. Nero Carbonio, Bianco Eldorado and Grigio Granito then complete the choice of exterior colours. Complementing these are four choices of interior trim: Red accents with White stitching on Black leather; Blue accents with Blue stitching on White leather; Blue accents with White stitching on Black leather; and White accents with Red stitching on Black leather.





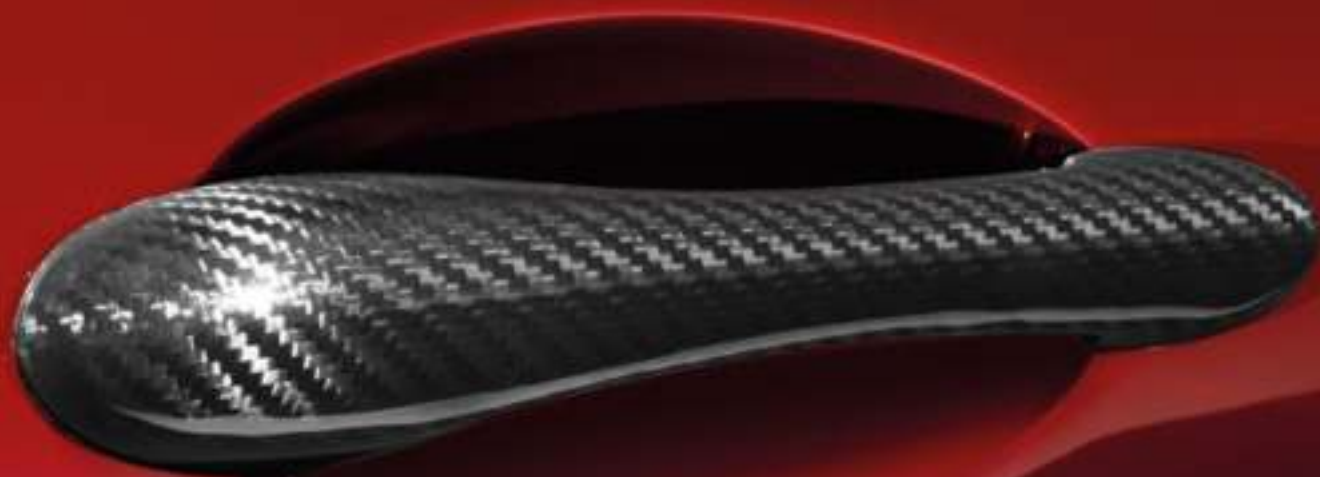



---

## GRANCABRIO SEDUCTIVELY COMBINES OPENNESS WITH AN AIR OF MYSTERY — IN A RANGE OF POSSIBILITIES

---

When passion meets freedom, the outcome is inevitably something very special, like the Maserati convertible range, which is comprised of the GranCabrio, GranCabrio Sport, GranCabrio MC and GranCabrio MC Centennial Edition. To drive these cars is a feast for the senses: their looks are simply stunning, their sounds are unforgettable, every surface is exquisite to the touch, and even their aroma arouses sensations of opulence and luxury. They are the summation of Maserati's long-cherished values: immense power, inspirational handling and all-enveloping luxury.





---

## MASERATI GRANCABRIO STYLE, SENSUALITY AND PASSION

---



The GranCabrio's elegant profile bears the unmistakable signature of Pininfarina. The imposing front end culminates in the horizontal headlamps that emerge seamlessly from the front wings, whilst the centrepiece of the radiator is a large, chrome Maserati Trident. The drama of the side view is accentuated by short overhangs, a long bonnet and striking 20-inch alloy wheels. The rear of the Maserati GranCabrio gives further emphasis to the car's sportiness and advanced technology: the triangular lamp clusters comprise some 96 LEDs to ensure maximum nighttime visibility. With the top up, the impression is of power, fluidity and muscularity, a look that is enhanced by new, rounded rear wings that match the aggressive look of the front. However, at the touch of a button, the car's character is transformed: the roof disappears and a gorgeous new shape reveals itself, all in the space of just 28 seconds.







---

## DESIGNED TO APPEASE ALL THE SENSES

---

The Maserati GranCabrio's unique spirit continues inside with a skillfully chosen blend of modernity, elegance, racing style and comfort — an interior to cosset everyone who experiences the GranCabrio, either as driver or passenger. In the cabin, all the materials are worked with precision and skill by expert craftsmen in leather and wood; inspiration and perfection are the only ways to describe the Maserati GranCabrio's interior. The first thing to strike the eye is the dashboard, which is highlighted by the central V-shape. The controls are located in such a way as to give the driver the feeling of total command: the major dynamic functions are operated by buttons on the driver's side, whilst the most commonly used multimedia controls can be activated via those on the

steering wheel. The functions are then displayed on the 7-inch screen of the Maserati Multimedia System, which is mounted in the centre of the dashboard in a raised position for optimum visibility. The all-round attention to detail manifests itself in numerous features, such as the subtle chrome inlay that elegantly decorates the buttons on the dashboard and steering wheel, the Trident emblem that is handcrafted on the seat headrests, the Alcantara® trim that lines the back of the gearshift paddles, and the prominent stitching of the front and rear armrests.

#### ENGINE AND TRANSMISSION

---

## EFFORTLESS PERFORMANCE

---

The GranCabrio is powered by Maserati's acclaimed 4.7-litre V8 engine that delivers 450 HP at 7,000 rpm, and 510 N•m of torque at 4,750 rpm. The banks are at a 90° angle and timing is by means of twin chain-drive overhead camshafts per bank, with four valves per cylinder controlled by hydraulic tappets. This unit uses the same technologies as all Maserati engines to deliver high specific power, smooth and instantaneous response and low running noise. The exhaust is controlled by pneumatic valves that, in Normal mode, are closed to ensure low, discreet noise levels. However, pressing the Sport button not only changes the car's performance and handling dynamics, but also opens the exhaust valves, thus enabling the engine to deliver maximum power with a stirring roar — which is even more thrilling to hear with the top down. A ZF 6-speed automatic gearbox is matched with the 4.7-litre engine — a combination that will impress the most demanding drivers with formidable acceleration, whilst still delivering smooth and fluid gear changes for the comfort of all on board.

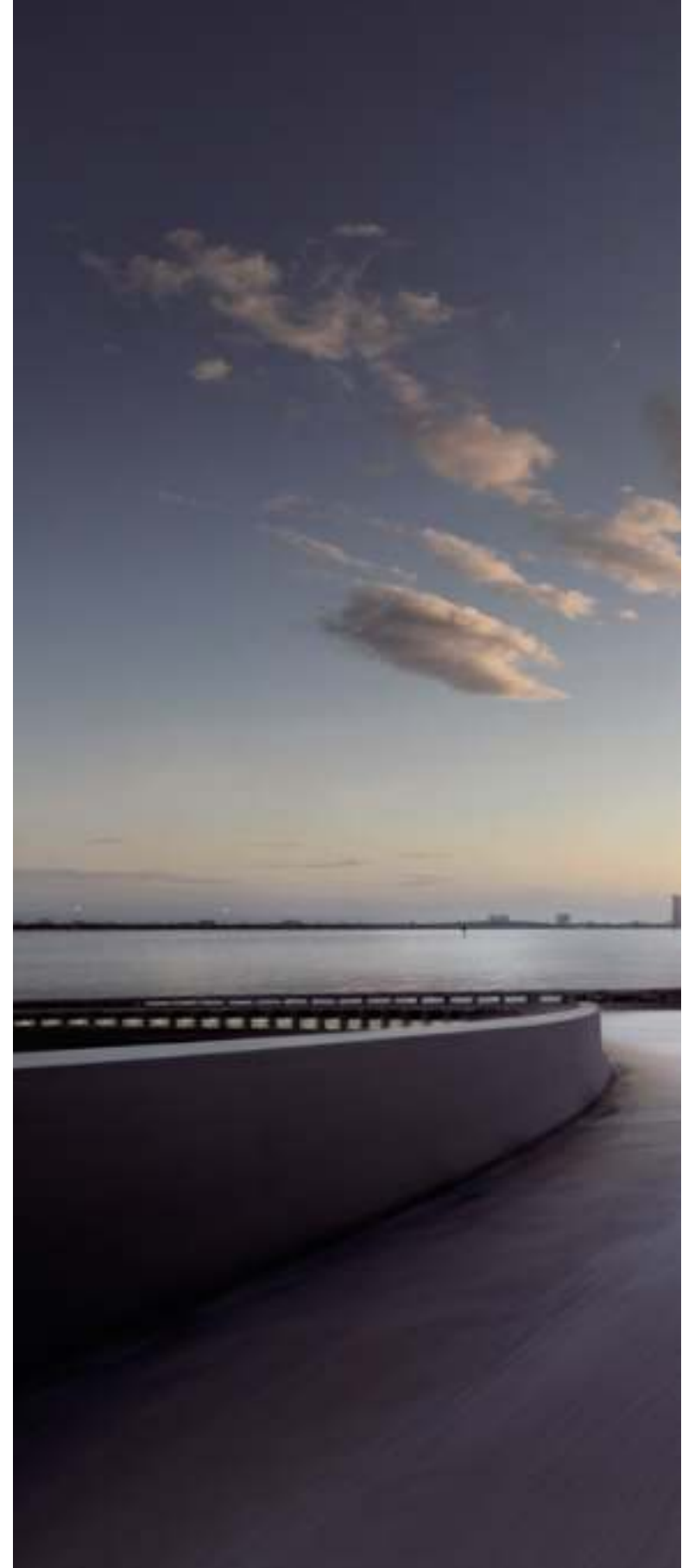



---

MASERATI GRANCABRIO SPORT  
ICONIC. INSPIRATIONAL. IRRESISTIBLE

---



The GranCabrio Sport's beauty strikes straight to the heart, with additional features that give its elegance and style an even sportier imprint. It is the natural evolution of the glorious GranCabrio, the brand's first four-seater convertible and the latest in a long line of outstanding open-top Maseratis.









---

## A POWERFUL PERSONALITY

---

The GranCabrio Sport's front bumper features two sinuous air intakes that run from the central spoiler towards the aggressive front light assembly, with its LED Daytime Running Lamps (DRLs). The famous radiator grille has Black vertical fillets, whilst the Trident in the centre sports Red details: a finishing touch only used on the most powerful models in the Maserati range. The standard sideskirts, available in black on request, have a pronounced shape that emphasises the dynamic

lines along the side of the car. As well as their stylistic role, these additions play an important part in the car's aerodynamics. Combined with the shape of the wings, they ensure optimal airflow towards the rear wheels: an example of form serving function. The Black tailpipes give the rear a decidedly racy look. Oval in shape, they make the model unmistakable and are also available in carbon fibre. Painstakingly designed in every detail to express power and speed, the GranCabrio Sport comes in a colour that underlines its personality: Rosso Trionfale (Triumphal Red). The addition of the generously sized 20-inch Astro Design alloy wheels gives the car an even more dynamic character. They are available in two shades: Silver; and Anthracite Grey, a finish with a striking metallic effect.

---

## COMFORT FOR FOUR

---

The GranCabrio Sport exerts a charm that is truly hypnotic. Excitingly aggressive yet with all the comfort and space expected of a car in its class, the GranCabrio Sport is uniquely tempting. To see it is to desire it. A true four-seater, the GranCabrio Sport allows all passengers to enjoy the pleasure of open-top travel. The soft Poltrona Frau® leather upholstery is available in two colours, Pregiato White and Chrono Grey, whilst the central section of the M-design seats feature contrasting stitching inspired by the sleek curves of the Maserati radiator grille. The front seats have an electric lumbar support adjustment system and can be equipped with the optional Comfort Package, which includes seat position memory and heating with three temperature settings. The embroidered Trident logo on the headrests adds to the sensation of fine craftsmanship, whilst the rear seats, individual and contoured like those at the front, provide a personalised, comfortable environment that never loses its sporty feel.





---

## THE IRRESISTIBLE APPEAL OF HIGH PERFORMANCE

---

Under the bonnet of the GranCabrio Sport lies a mighty engine with prodigious power and a deep, sonorous note to match. This glorious 4.7-litre V8 delivers 450 HP at 7,000 rpm, and 520 N•m of torque. The camshafts on the intake side are fitted with CVVT (Continuously Variable Valve Timing), and the single timing chain makes the engine exceptionally reliable and quiet. The DLC (Diamond-Like Coating) of the camshaft lobes mean very low friction levels, which in turn means improved efficiency overall. The GranCabrio Sport features a 6-speed transmission with a choice of five operating modes: Auto Normal, Auto Sport, Manual Normal, Manual Sport and Ice. Selecting Auto Sport mode activates the MC Auto Shift function and the best possible performance: acceleration from 0 – 62 mph in just 5.0 seconds. In addition, it includes electronic double-declutching when downshifting and features extra long Trofeo Design paddles, which were developed specifically for this model.





140 170

28°C

110 200

km/h

km/h

80

230

50

260

20

290



320

5

6

7

8

9

130

5



---

MASERATI GRANCABRIO MC  
SPORTS PERFORMANCE SCALES NEW HEIGHTS

---



When it comes to the design and construction of convertibles of unique and inimitable beauty, the Maserati tradition reaches new heights with the GranCabrio MC. This very special car maintains the elegant, luxury style of Maserati's first genuine four-seater cabriolet, the GranCabrio, with the added benefit of the technological expertise gained on the racetrack by Maserati Corse.





---

## BELOW THE SPORTY EXTERIOR LIES A SOPHISTICATED SOUL

---

With its silhouette perfected in a wind tunnel, the GranCabrio has been a great success for Maserati and has penned an entire new chapter in the company's history. Now Maserati technicians have introduced a series of further aerodynamic improvements for its ultimate cabriolet, the GranCabrio MC. A spoiler and air intakes give the car an even more muscular look; together with the slots on the front bumpers and the sideskirts, they extract hot air from the braking system and maximise downforce without increasing drag. The rear is equally dramatic, with a higher, more centrally positioned exhaust, and the lower edge of the bumper is designed to improve the airflow at the back of the car. The spoiler incorporates the third stoplamp and is designed to maximise downforce at high speeds. The stylish yet sporty look is further enhanced by special touches like the Bianco Birdcage three-layer paint finish, which brings the bodywork to life with a special bluish tinge. The GranCabrio MC's dynamic look is further emphasised by the 20-inch MC Design wheels, available in bright Titanium or Matte Graphite finishes.



---

## THE IDEAL PLACE TO DISCOVER THE ULTIMATE IN SPORTY OPEN-TOP DRIVING

---



Hands on the sporty steering wheel, fingers ready to caress the gearshift paddles, right foot ready to unleash the acceleration that the V8 engine is growling to deliver. Driving the GranCabrio MC is a truly unique experience. The design of the wraparound sports seats echoes the elegant lines of the exterior. The headrests integrated into the seatbacks, embossed with the Maserati logo, sit atop larger, extra-comfortable seats that also provide enhanced support during sporty driving. The revised three-spoke sports steering wheel has a more heavily profiled grip, whilst the top and bottom of the rim are flattened to make it even more compact. Behind it are the longer Trofeo Design gearshift paddles, which are available in carbon fibre on request. Meanwhile, the accelerator and brake pedals come in perforated aluminium, as standard, to ensure optimum lightness and grip. For those in search of an even more adrenalin-filled interior there is the Alcantara® Package. Lighter than leather, this high-tech material can be used to clad a large proportion of the interior.







---

## ROARING PERFORMANCE AT THE TOUCH OF THE ACCELERATOR

---

The heart of the GranCabrio MC is the legendary 4.7-litre V8 engine. In keeping with the Maserati tradition, this engine features a series of innovations that make it incredibly powerful and flexible, so it can guarantee the smoothest of rides, not to mention plenty of thrills. Excitement is delivered through the car's amazing performance: 460 HP, a top speed of 179 mph, and 0 – 62 mph in just 4.9 seconds. The 6-speed automatic gearbox features auto-adaptive software that automatically responds to the driving style and conditions, modifying the gear-shifting pattern accordingly. It uses MC Auto Shift technology, which operates in a variety of ways to make driving even more satisfying according to the prevailing conditions: for instance, in Manual mode, gear changing can take place at any time, right up to the limiter actuation point.

GRANCABRIO MC CENTENNIAL EDITION

---

## ONE EXTREMELY OPULENT OPEN-AIR CELEBRATION

---

They say true passion endures, a sentiment proven by the over one-hundred-year-long success of Maserati. It was December 1914 when three brothers — Alfieri, Ettore and Ernesto Maserati opened their garage in the heart of Bologna. They were fiercely passionate about their work, inspiring continued innovation and a dedication to the excellence that is at the root of the marque's longevity. How to mark this special anniversary? The very special Maserati GranCabrio MC Centennial Edition. As fitting for such an occasion, the model is adorned with special finishes and trims, along with features and detailing that are completely unique — all paired with GranCabrio's inherent top-down, let-your-hair-fly driving experience. We think the brothers would agree: every minute behind the wheel of the GranCabrio MC Centennial Edition is a worthy celebration.











---

GRANCABRIO MC CENTENNIAL EDITION ICONIC. INK BLUE  
SETS THE SEAL ON A MODERN DAY MASTERPIECE

---



With racing looks designed to excite and inspire, the GranCabrio MC Centennial Edition makes a unique and totally stunning visual statement through its special new Blu Inchiostro (Ink Blue) colour. This special three-coat finish of the bodywork, with deep, dark glints, has been specifically developed to combine with the lighter shades of the interior. The car's exterior is made even more aggressive by various carbon fibre features: the rear spoiler, door handles and door mirror casings. In addition, there is a feature borrowed from the GranTurismo MC Stradale that is not normally found on this model: the ultra-lightweight, body-coloured, carbon fibre engine cover with an aggressive central air intake and two side air vents. The car's lightness is further emphasised by the forged 20-inch Matte Smoke Trofeo Design wheels, through which there are glimpses of the anodised Matte Blue brake calipers. The other three-coat special colours created to celebrate Maserati's centennial have been designed to match specific interiors: Rosso Magma, Grigio Pietra (with mica providing an original metallic effect) and Bianco Birdcage. The selection is then completed by the availability of Nero Carbonio, Bianco Eldorado and Grigio Granito. Like its GranTurismo Centennial Edition cousin, the GranCabrio MC Centennial Edition comes with four new choices of interior trim: Red accents with White stitching on Black leather; Blue accents with Blue stitching on White leather; Blue accents with White stitching on Black leather; and White accents with Red stitching on Black leather.







## PERSONALISATION

---

### A CAR CRAFTED TO REFLECT YOUR PERSONALITY

---

Maserati has been manufacturing extremely high-performance cars with impeccable finishes for over a century. However, as every one of us has our own personal taste and preferences, a vast number of details on the GranTurismo can be customised — consequently there is a vast choice of colours for the bodywork, the leather upholstery, the carpets and the contrast stitching, plus a wide range of choice woods. High-class materials are used to furnish the interiors: Poltrona Frau® leather and Alcantara®.

A vast selection is available, allowing the creation of a wide range of customised solutions. There are 10 leather colours for the seats, dashboard, central console, rear shelf, steering wheel and gear lever knob, 14 thread colours of the contrast stitching, and 9 carpet colours. Further customisation is available in the moldings of the dashboard, door panels and rear side panels: the standard Dark Chrome or Eco Chrome can be replaced with four different choice woods for a warm, elegant interior, or two varnished colours for a more sporty, exclusive look. The on-board equipment may also be supplemented with high-tech devices, such as the electrochromatic rearview mirrors, which darken progressively as light intensity increases (as standard for the internal rearview mirror), or the Tyre Pressure Monitoring System (TPMS), which continually monitors tyre pressure when the car is on the move.

## MASERATI GRANTURISMO RANGE

GranTurismo

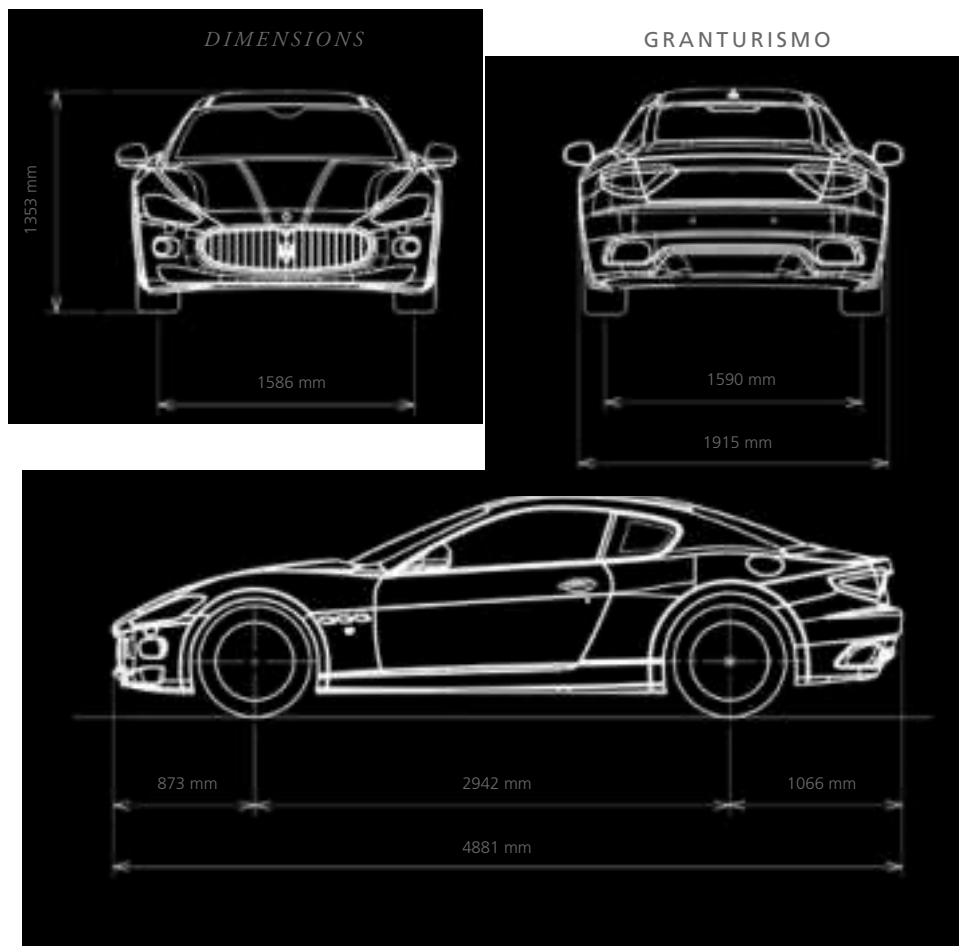

### DIMENSIONS AND WEIGHTS

Length	4881 mm
Width (with side mirrors)	2056 mm
Width (without side mirrors)	1915 mm
Height	1353 mm
Wheelbase	2942 mm
Dry weight (EU version)	1780 kg
Kerb weight (EU version)	1880 kg
Boot capacity	260 l
Fuel tank capacity	86 l
Weight distribution	49% front – 51% rear
Turning circle	10.7 m

### GRANTURISMO

### TYRES

Front tyres	245/40 ZR19
Rear tyres	285/40 ZR19

### ENGINE

Number of cylinders and layout	V8 90°
Displacement	4244 cc
Compression ratio	11.01:1

### PERFORMANCE

Max power output	405 HP (302 kW)
Engine speed at max power output	7100 rpm
Peak torque	460 Nm (47 kgm)
Engine speed at peak torque	4750 rpm
Maximum speed (km/h)	285 (177 mph)
Acceleration 0 – 100 km/h	5.2 s
Breaking distance from 100 km/h – 0	36 m

### CONSUMPTION AND EMISSIONS

Fuel consumption - urban cycle (l/100 km)	21.5 (13.1 mpg)
Fuel consumption - extra urban cycle (l/100 km)	10.0 (28.2 mpg)
Fuel consumption - combined cycle (l/100 km)	14.3 (19.8 mpg)
CO <sub>2</sub> emissions - combined cycle (g/km)	330
Regulation	Euro 6



Yellow

Red

Blue

Titanium

Silver

Black



**V-STYLE**



**V-STYLE  
GRIGIO MERCURY**

\* Front tyre: 8.5J x 19"  
\* Rear tyre: 10.5J x 19"

\* Front tyre: 8.5J x 19"  
\* Rear tyre: 10.5J x 19"



**BIRDCAGE  
SILVER**



**BIRDCAGE  
GRIGIO MERCURY**



**NEPTUNE DESIGN  
BLACK**

\* Front tyre: 8.5J x 20"  
\* Rear tyre: 10.5J x 20"

\* Front tyre: 8.5J x 20"  
\* Rear tyre: 10.5J x 20"

\* Front tyre: 8.5J x 20"  
\* Rear tyre: 10.5J x 20"

## MASERATI GRANTURISMO RANGE

GranTurismo Sport

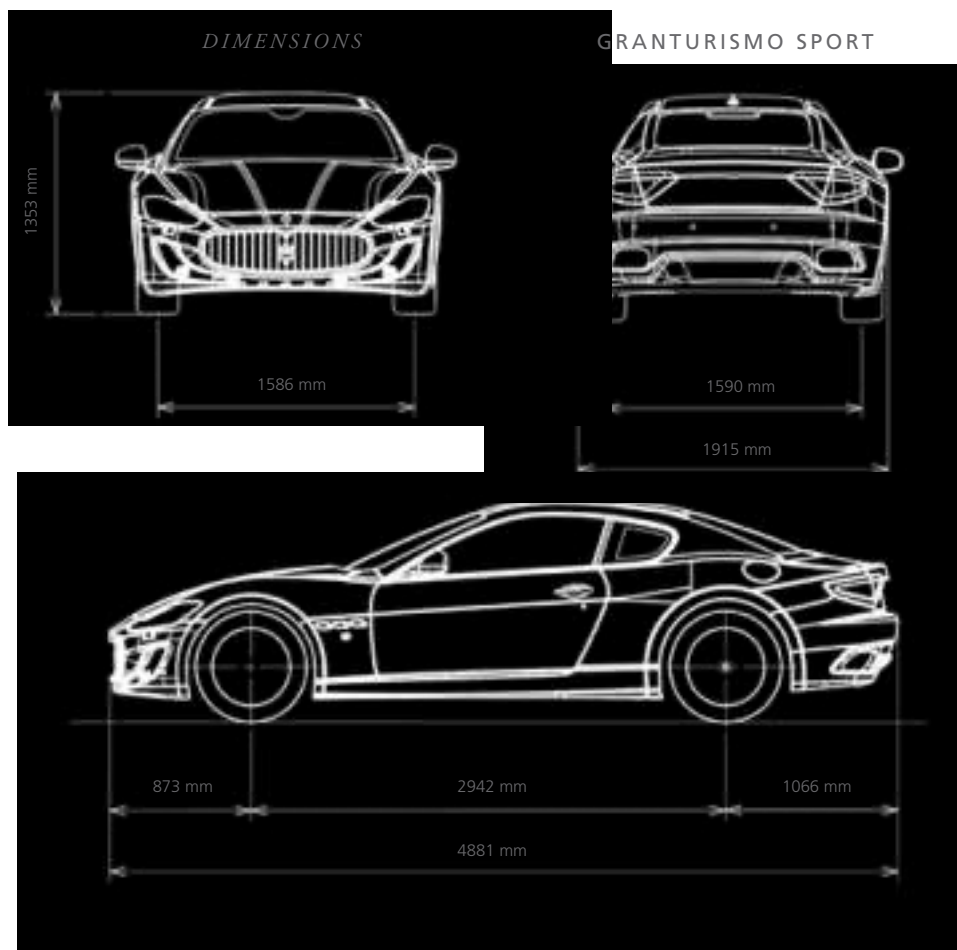

## DIMENSIONS AND WEIGHTS

Length	4881 mm
Width (with side mirrors)	2056 mm
Width (without side mirrors)	1915 mm
Height	1353 mm
Wheelbase	2942 mm
Dry weight (EU version)	1780 kg
Kerb weight (EU version)	1880 kg
Boot capacity	260 l
Fuel tank capacity	86 l
Weight distribution	49% front – 51% rear
Turning circle	10.7 m

## TYRES

Front tyres	245/35 ZR20
Rear tyres	285/35 ZR20

## ENGINE

Number of cylinders and layout	V8 90°
Displacement	4691 cc
Compression ratio	11.25:1

## PERFORMANCE

Max power output	460 HP (338 kW)
Engine speed at max power output	7000 rpm
Peak torque	520 Nm (53 kgm)
Engine speed at peak torque	4750 rpm
Maximum speed (km/h)	298 (185 mph) MC Auto Shift 300 (186 mph) MC Shift
Acceleration 0 – 100 km/h	4.8 s (MC Auto Shift) 4.7 s (MC Shift)
Breaking distance from 100 km/h – 0	35 m

## CONSUMPTION AND EMISSIONS

Fuel consumption - urban cycle (l/100 km)	23.8 (11.9 mpg) MC Shift 21.9 (12.9 mpg) MC Auto Shift
Fuel consumption - extra urban cycle (l/100 km)	10.7 (26.4 mpg) MC Shift 9.8 (28.8 mpg) MC Auto Shift
Fuel consumption - combined cycle (l/100 km)	15.5 (18.2 mpg) MC Shift 14.3 (19.7 mpg) MC Auto Shift
CO <sub>2</sub> emissions - combined cycle (g/km)	360 (MC Shift) 331 (MC Auto Shift)
Regulation	Euro 6



Polished Aluminum

Yellow

Red

Blue

Anodized Matt Blue

Titanium

Silver

Black

Anodized Matt Red



**ASTRO DESIGN  
SILVER**



**ASTRO DESIGN  
SHINY ANTRACITE GREY**



**BIRDCAGE  
SILVER**



**BIRDCAGE  
GRIGIO MERCURY**



**TRIDENT DESIGN  
SILVER**



**TRIDENT DESIGN  
GRIGIO MERCURY**

\* Front tyre: 8.5J x 20"  
\* Rear tyre: 10.5J x 20"

\* Front tyre: 8.5J x 20"  
\* Rear tyre: 10.5J x 20"

\* Front tyre: 8.5J x 20"  
\* Rear tyre: 10.5J x 20"

\* Front tyre: 8.5J x 20"  
\* Rear tyre: 10.5J x 20"

\* Front tyre: 8.5J x 20"  
\* Rear tyre: 10.5J x 20"

\* Front tyre: 8.5J x 20"  
\* Rear tyre: 10.5J x 20"



**MC DESIGN  
TITANIO**



**MC DESIGN GRAFITE  
MATT (FORGED)**



**NEPTUNE DESIGN  
SILVER**



**NEPTUNE DESIGN  
GRIGIO MERCURY**



**NEPTUNE DESIGN  
BLACK**

\* Front tyre: 8.5J x 20"  
\* Rear tyre: 10.5J x 20"

\* Front tyre: 8.5J x 20"  
\* Rear tyre: 10.5J x 20"

\* Front tyre: 8.5J x 20"  
\* Rear tyre: 10.5J x 20"

\* Front tyre: 8.5J x 20"  
\* Rear tyre: 10.5J x 20"

\* Front tyre: 28.5J x 20"  
\* Rear tyre: 10.5J x 20"

## MASERATI GRANTURISMO RANGE

GranTurismo MC Stradale

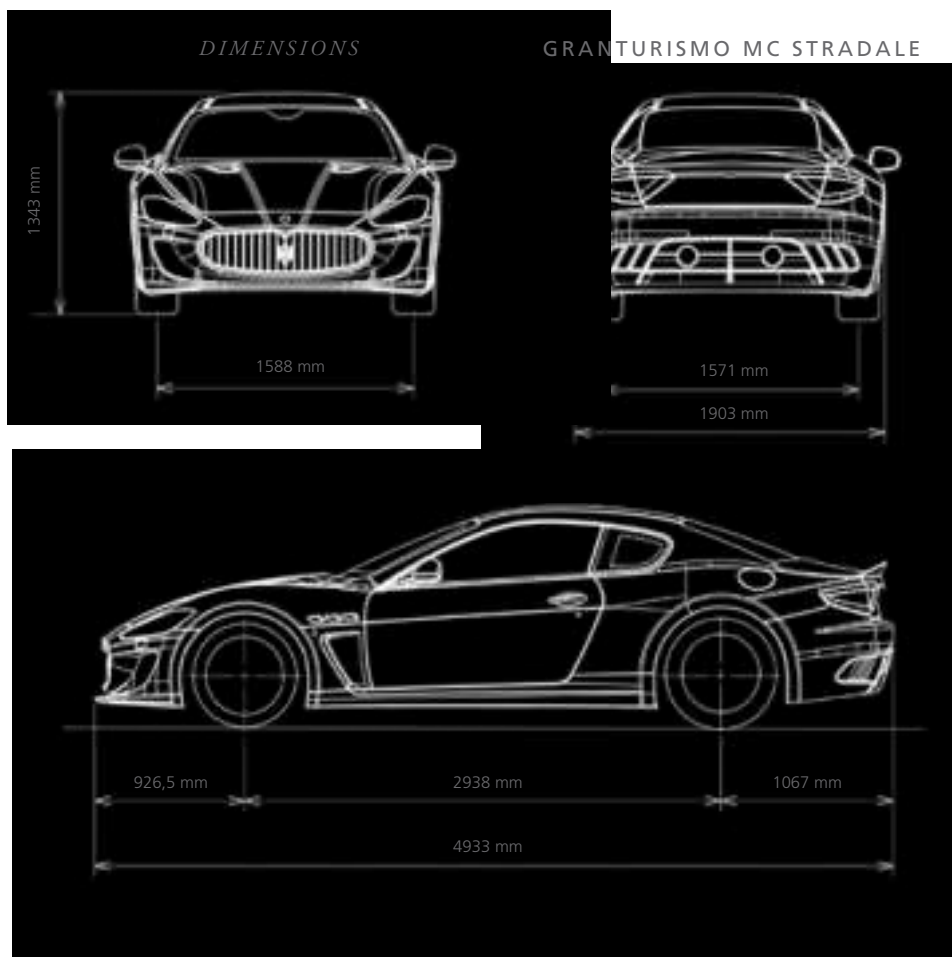

### DIMENSIONS AND WEIGHTS

Length	4933 mm
Width (with side mirrors)	2044 mm
Width (without side mirrors)	1903 mm
Height	1343 mm
Wheelbase	2938 mm
Dry weight (EU version)	1700 kg
Kerb weight (EU version)	1800 kg
Boot capacity	320 l
Fuel tank capacity	90 l
Weight distribution	48% front – 52% rear
Turning circle	10.5 m

### TYRES

Front tyres	2455/35 ZR20
Rear tyres	295/35 ZR20

### ENGINE

Number of cylinders and layout	V8 90°
Displacement	4691 cc
Compression ratio	11.1:1

### PERFORMANCE

Max power output	460 HP (338 kW)
Engine speed at max power output	7000 rpm
Peak torque	520 Nm (53 kgm)
Engine speed at peak torque	4750 rpm
Maximum speed (km/h)	303 (188 mph)
Acceleration 0 – 100 km/h	4.5 s
Breaking distance from 100 km/h – 0	33 m

### CONSUMPTION AND EMISSIONS

Fuel consumption - urban cycle (l/100 km)	23.8 (11.9 mpg)
Fuel consumption - extra urban cycle (l/100 km)	10.7 (26.4 mpg)
Fuel consumption - combined cycle (l/100 km)	15.5 (18.2 mpg)
CO <sub>2</sub> emissions - combined cycle (g/km)	360
Regulation	Euro 6



Anodized Matt Blue Yellow

Black

Red

Titanium



**TROFEO DESIGN  
SILVER (FORGED)**

\* Front tyre: 8.5J x 20"  
\* Rear tyre: 10.5J x 20"



**TROFEO DESIGN  
POLISHED (FORGED)**

\* Front tyre: 8.5J x 20"  
\* Rear tyre: 10.5J x 20"



**MC DESIGN  
TITANIO**

\* Front tyre: 8.5J x 20"  
\* Rear tyre: 10.5J x 20"



**MC DESIGN GRAFITE  
MATT (FORGED)**

\* Front tyre: 8.5J x 20"  
\* Rear tyre: 10.5J x 20"



**NEPTUNE DESIGN  
BLACK**

\* Front tyre: 8.5J x 20"  
\* Rear tyre: 10.5J x 20"

**MASERATI GRANTURISMO RANGE**  
GranTurismo MC Stradale Centennial Edition

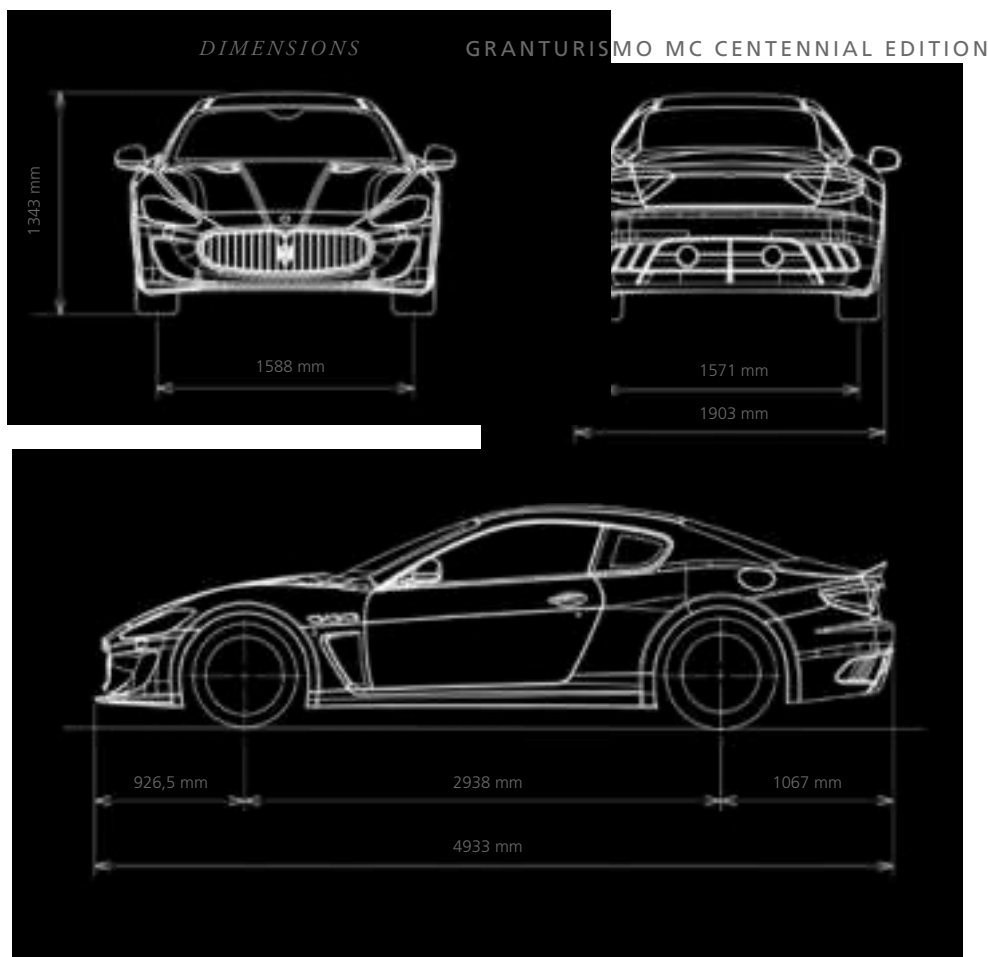

**DIMENSIONS AND WEIGHTS**

Length	4933 mm
Width (with side mirrors)	2044 mm
Width (without side mirrors)	1903 mm
Height	1343 mm
Wheelbase	2938 mm
Dry weight (EU version)	1700 kg
Kerb weight (EU version)	1800 kg
Boot capacity	320 l
Fuel tank capacity	90 l
Weight distribution	48% front – 52% rear
Turning circle	10.5 m

**GRANTURISMO  
MC STRADALE  
CENTENNIAL EDITION**

**TYRES**

Front tyres	245/35 ZR20
Rear tyres	295/35 ZR20

**ENGINE**

Number of cylinders and layout	V8 90°
Displacement	4691 cc
Compression ratio	11.1:1

**PERFORMANCE**

Max power output	460 HP (338 kW)
Engine speed at max power output	7000 rpm
Peak torque	520 Nm (53 kgm)
Engine speed at peak torque	4750 rpm
Maximum speed (km/h)	303 (188 mph)
Acceleration 0 – 100 km/h	4.5 s
Breaking distance from 100 km/h – 0	33 m

**CONSUMPTION AND EMISSIONS**

Fuel consumption - urban cycle (l/100 km)	23.8 (11.9 mpg)
Fuel consumption - extra urban cycle (l/100 km)	10.7 (26.4 mpg)
Fuel consumption - combined cycle (l/100 km)	15.5 (18.2 mpg)
CO <sub>2</sub> emissions - combined cycle (g/km)	360
Regulation	Euro 6



Anodized Matt Blue

Yellow

Black

Red

Titanium



**MC DESIGN CHARCOAL  
WITH WHITE ACCENTS**

\* Front tyre: 8.5J x 20"  
\* Rear tyre: 10.5J x 20"



**MC DESIGN CHARCOAL  
WITH RED ACCENTS**

\* Front tyre: 8.5J x 20"  
\* Rear tyre: 10.5J x 20"



**MC DESIGN CHARCOAL  
WITH BLUE ACCENTS**

\* Front tyre: 8.5J x 20"  
\* Rear tyre: 10.5J x 20"



**TROFEO DESIGN  
MATT SMOKE**

\* Front tyre: 8.5J x 20"  
\* Rear tyre: 10.5J x 20"

SOLID PAINTS

METALLIC PAINTS

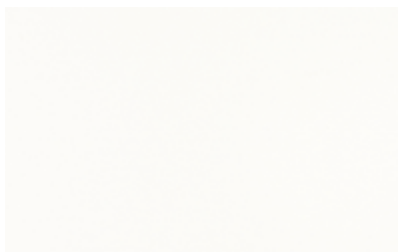

Bianco Eldorado

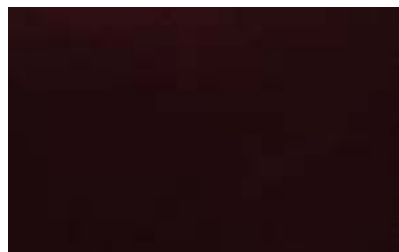

Bordeaux Pontevecchio



Blu Sofisticato



Grigio Alfieri



Blu Nettuno



Nero

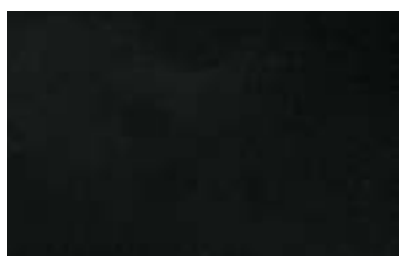

Nero Carbonio



Blu Oceano



Rosso Trionfale

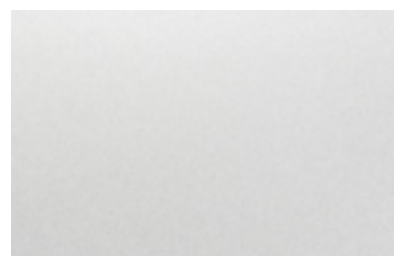

Grigio Touring

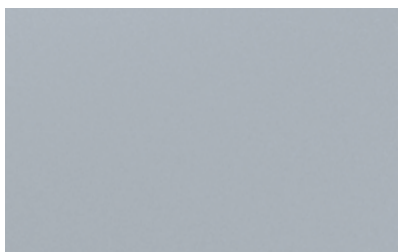

Grigio Pietra



Blu Inchiostro



Rosso Magma



Grigio Granito

**SPECIAL PAINTS**



Giallo Granturismo



Blu Mediterraneo

**MATT PAINTS**



Blu Mediterraneo



Bianco Birdcage



Rosso Mondiale



Grigio Granito

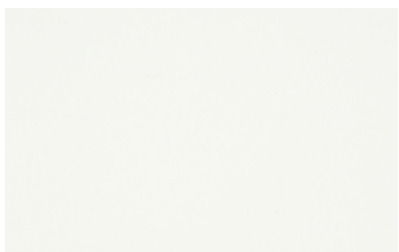

Bianco Fuji



Grigio Lava

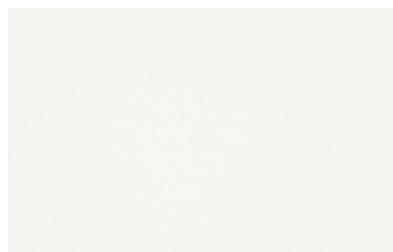

Bianco Fuji

	GT	GT SPORT	GT MC	GT MC 100
<b>SOLID PAINTS</b>				
Bianco Eldorado	●	●	●	●
Nero	●	●	●	
<b>METALLIC PAINTS</b>				
Blu Inchiostro				●
Blu Nettuno	●	●		
Blu Oceano	●	●		
Blu Sofisticato	●	●	●	
Bordeaux Pontevecchio	●	●		
Grigio Alfieri	●	●		
Grigio Granito	●	●	●	●
Grigio Pietra				●
Grigio Touring	●	●	●	
Nero Carbonio	●	●	●	●
Rosso Magma				●
Rosso Trionfale	●	●	●	
<b>SPECIAL PAINTS</b>				
Bianco Birdcage	●	●	●	●
Bianco Fuji	●	●	●	
Blu Mediterraneo	●	●	●	
Giallo Granturismo	●	●	●	
Grigio Lava	●	●	●	
Rosso Mondiale	●	●	●	
<b>MATT PAINTS</b>				
Bianco Fuji	●	●	●	
Blu Mediterraneo	●	●	●	
Grigio Granito	●	●	●	

LEATHERS



Pearl Beige

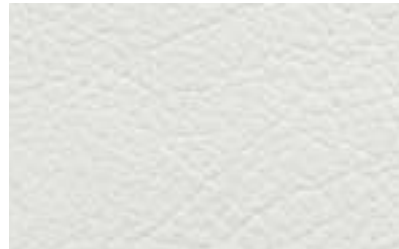

Bianco Pregiato



Sabbia



Cuoio



Bordeaux



Marrone Corniola

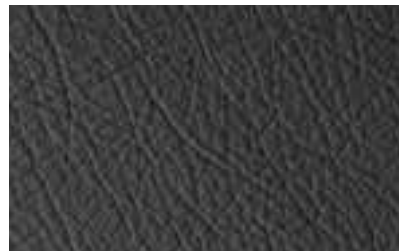

Grigio Chrono



Blu Profondità



Rosso Corallo



Nero

ALCANTARA®

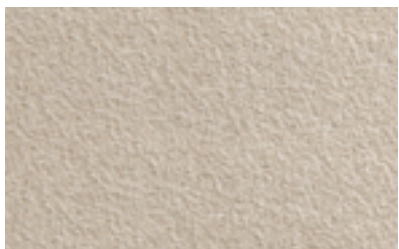

Pearl Beige

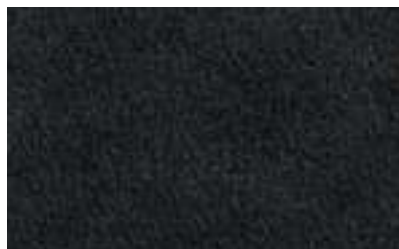

Nero

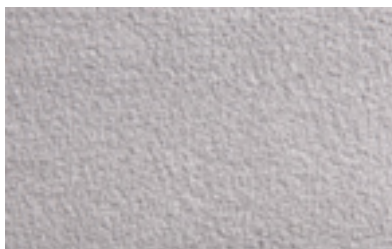

Grigio

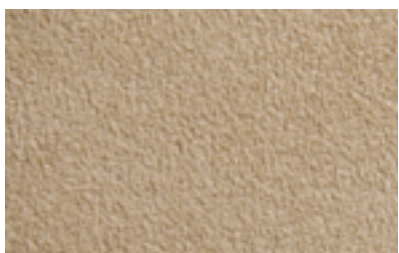

Beige



Blu Trofeo

SEAT COLORS	GT	GT SPORT	GT MC	GT MC 100
<b>LEATHERS</b>				
Bianco Pregiato	●	●	●	●
Blu Profondità	●	●	●	
Bordeaux	●	●	●	
Cuoio	●	●	●	
Grigio Chrono	●	●	●	
Marrone Corniola	●	●	●	
Nero	●	●	●	●
Pearl Beige	●	●	●	
Rosso Corallo	●	●	●	
Sabbia	●	●	●	
<b>ALCANTARA®</b>				
Beige		●	●	
Blu Trofeo		●	●	
Grigio		●	●	
Nero		●	●	
Pearl Beige		●	●	

**LEATHERS**

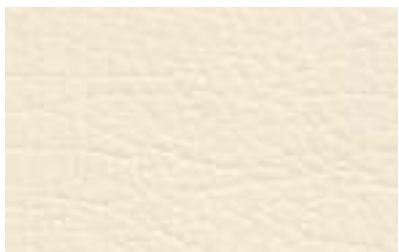

Pearl Beige

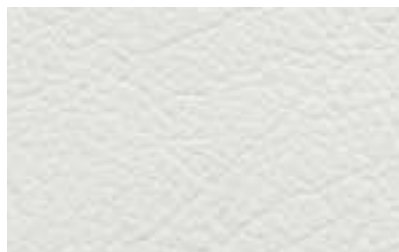

Bianco Pregiato



Sabbia



Cuoio



Bordeaux



Marrone Corniola

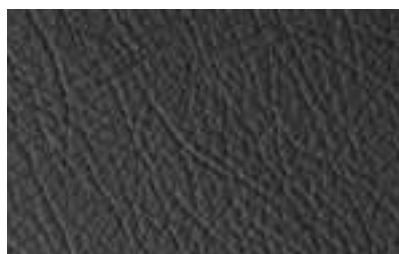

Grigio Chrono



Blu Profondità



Rosso Corallo



Nero

**ALCANTARA®**

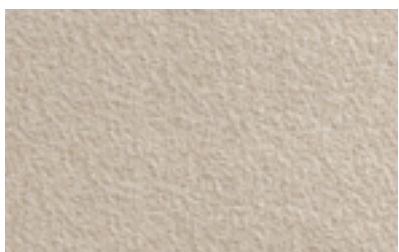

Pearl Beige

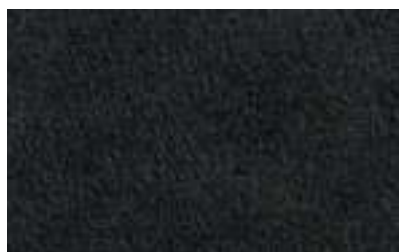

Nero

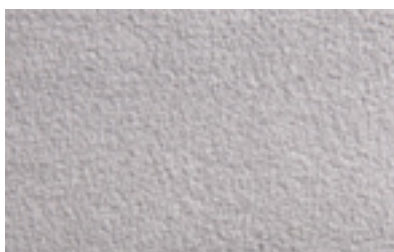

Grigio

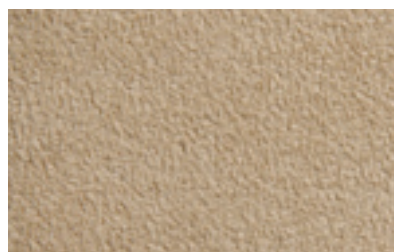

Beige



Blu Trofeo

**TRIM — METAL**



Dark Chrome

Eco Chrome

Nero Soft

**TRIM — WOOD**

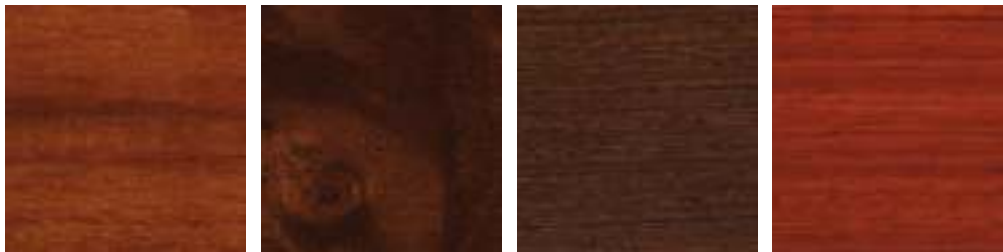

Rosewood

Walnut Briarwood

Wengè

Padouk

**TRIM — FIBRE**

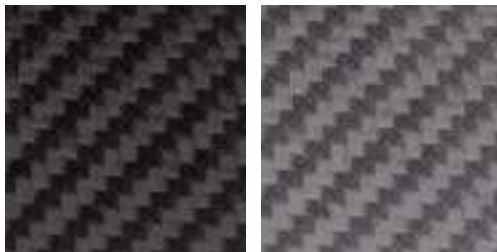

Carbon Fibre

TitanTex

**TRIM — HIGH GLOSS**



Black Piano

Blue Laque

	GT	GT SPORT	GT MC	GT MC 100		GT	GT SPORT	GT MC	GT MC 100
<b>DASHBOARD</b>					<b>STEERING WHEEL</b>				
<b>LEATHERS</b>					<b>LEATHERS</b>				
Blu Profondità	●	●	●		Bianco Pregiato	●	●	●	
Bordeaux	●	●	●		Blu Profondità	●	●	●	
Cuoio	●	●	●		Bordeaux	●	●	●	
Grigio Chrono	●	●	●		Cuoio	●	●	●	
Marrone Corniola	●	●	●		Grigio Chrono	●	●	●	
Nero	●	●	●	●	Marrone Corniola	●	●	●	
Rosso Corallo	●	●	●		Pearl Beige	●	●	●	
					Nero	●	●	●	●
<b>DASHBOARD TRIM</b>					<b>STEERING TRIM</b>				
<b>METAL</b>					<b>FIBRE</b>				
Dark Chrome	●	●	●		Beige		●	●	
Eco Chrome	●	●	●		Blu Trofeo		●	●	
Nero Soft				● ●	Grigio		●	●	
<b>FIBRE</b>					<b>WOOD</b>				
Carbon Fibre		●	●	●	Nero		●	●	
TitanTex		●	●		Pearl Beige		●	●	
<b>WOOD</b>					<b>HIGH GLOSS</b>				
Padouk	●	●	●		Black Piano	●	●	●	
Walnut Briarwood	●	●	●		Blue Laque	●	●	●	
Rosewood	●	●	●						
Wengè	●	●	●		<b>HEADLINING</b>				
					<b>LEATHERS</b>				
<b>HIGH GLOSS</b>					<b>LEATHERS</b>				
Black Piano	●	●	●		Beige	●	●	●	●
Blue Laque	●	●	●		Grigio Chrono	●	●	●	●
					Pearl Beige	●	●	●	●
					Nero	●	●	●	●
<b>ALCANTARA®</b>					<b>ALCANTARA®</b>				
Beige	●	●	●	●	Beige	●	●	●	●
Blu Trofeo	●	●	●	●	Blu Trofeo	●	●	●	●
Grigio	●	●	●	●	Grigio	●	●	●	●
Nero	●	●	●	●	Nero	●	●	●	●
Pearl Beige	●	●	●	●	Pearl Beige	●	●	●	●
					<b>STEERING TRIM</b>				
					<b>FIBRE</b>				
					Carbon Fibre	●	●	●	●
					<b>WOOD</b>				
					Padouk	●	●	●	
					Walnut Briarwood	●	●	●	
					Rosewood	●	●	●	
					Wengè	●	●	●	
					<b>HIGH GLOSS</b>				
					Black Piano	●	●	●	

CARPETS AND CONTRAST STITCHING

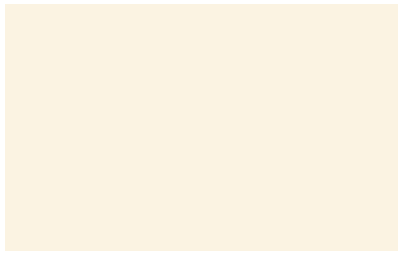

Pearl Beige

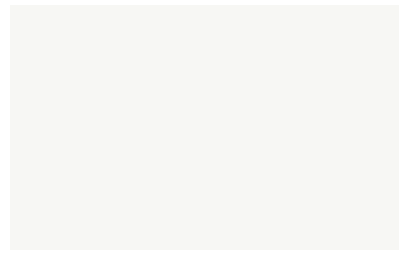

Bianco Pregiato



Beige



Cuoio



Bordeaux

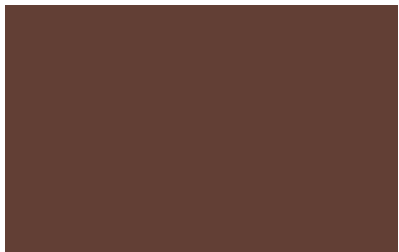

Marrone Corniola



Grigio Chrono



Blu Profondità



Rosso Corallo

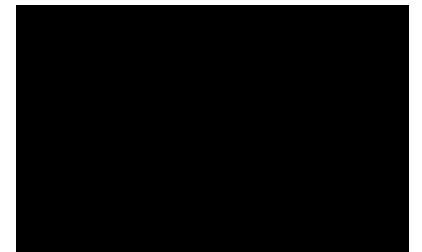

Nero

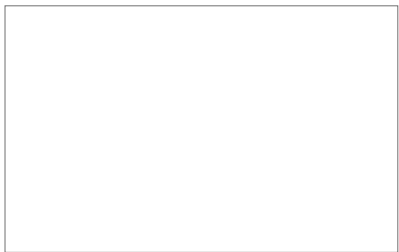

Bianco



Grigio Ghiaccio



Blu Navy



Giallo



Blu Sofisticato

**SEAT BELTS**

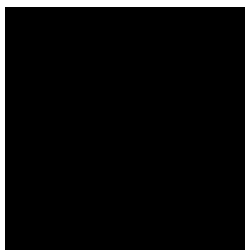

Nero



Grigio

CARPET	GT	GT SPORT	GT MC	GT MC 100	CONTRAST STITCHING	GT	GT SPORT	GT MC	GT MC 100
<b>COLOR</b>					<b>SEATS</b>				
Beige	●	●	●		Bianco	●	●	●	●
Blu Navy	●	●	●		Bianco Pregiato	●	●	●	
Bordeaux	●	●			Blu Navy	●	●	●	
Cuoio	●	●	●		Blu Sofisticato	●	●	●	●
Grigio Chrono	●	●	●		Bordeaux	●	●	●	
Marrone Corniola	●	●	●		Cuoio	●	●	●	
Nero	●	●	●	●	Giallo	●	●	●	
Pearl Beige	●	●	●		Grigio Chrono	●	●	●	
Nero	●	●	●	●	Grigio Ghiaccio	●	●	●	
Rosso Corallo	●	●			Marrone Corniola	●	●	●	
					Nero	●	●	●	
					Pearl Beige	●	●	●	
					Rosso Corallo	●	●	●	●
					Sabbia	●	●	●	
					<b>SEAT BELTS</b>				
					<b>COLOR</b>				
					Grigio	●	●	●	
					Nero	●	●	●	●

MASERATI GRANTURISMO RANGE Standard and Optional Equipment

	GT	GT SPORT MC Shift	GT SPORT MC Auto Shift	GT MC Stradale
<b>WHEELS AND CHASSIS</b>				
19-inch Grigio Mercury V-style alloy wheels (8.5J x 19" front; 10.5J x 19" rear)	○	—	—	○
19-inch V-style alloy wheels (8.5J x 19" front; 10.5J x 19" rear)	●	○	○	○
20-inch Astro Design alloy wheels (8.5J x 20" front; 10.5J x 20" rear)	—	●	●	—
20-inch Shiny Antracite Grey Astro Design alloy wheels (8.5J x 20" front; 10.5J x 20" rear)	—	○	○	—
20-inch Silver Neptune Design alloy wheels (8.5J x 20" front; 10.5J x 20" rear)	○	○	○	○
20-inch Grigio Mercury Neptune Design alloy wheels (8.5J x 20" front; 10.5J x 20" rear)	—	○	○	—
20-inch Silver Birdcage Design alloy wheels (8.5J x 20" front; 10.5J x 20" rear)	○	○	○	—
20-inch Grigio Mercury Birdcage Design alloy wheels (8.5J x 20" front; 10.5J x 20" rear)	○	○	○	—
20-inch Silver Trident Design alloy wheels (8.5J x 20" front; 10.5J x 20" rear)	—	○	○	—
20-inch Grigio Mercury Trident Design alloy wheels (8.5J x 20" front; 10.5J x 20" rear)	—	○	○	—
20-inch Titanium finish MC Design alloy wheels (8.5J x 20" front; 10.5J x 20" rear)	—	○	○	○
20-inch Matt Graphite finish MC Design forged alloy wheels (8.5J x 20" front; 10.5J x 20" rear)	—	○	○	○
20-inch Silver Trofeo Design forged alloy wheels (8.5J x 20" front; 10.5J x 20" rear)	—	—	—	●
20-inch Trofeo Design forged alloy wheels — Machine Polished finishing (8.5J x 20" front; 10.5J x 20" rear)	—	○	○	○
20-inch Gloss Black Neptune Design alloy wheels (8.5J x 20" front; 10.5J x 20" rear)	○	○	○	○
Brake calipers painted — Red	○	●	○	○
Brake calipers painted — Black	●	○	●	○
Brake calipers painted — Silver	○	○	○	○
Brake calipers painted — Blue	○	○	○	○
Brake calipers painted — Yellow	○	○	○	○
Brake calipers painted — Titanium	○	○	○	●
Brake calipers in anodized Matt Red	—	○	○	—
Brake calipers in anodized Matt Blue	—	○	○	○
Brake calipers in Polished Aluminium	—	○	○	—
Ventilated brakes with cross-drilled and grooved discs: dual-cast, 360 mm with 6-piston calipers at front; 330 mm with 4-piston calipers at rear	—	●	●	—
Skyhook — electronically variable active damping system	○	—	—	—
Sport Skyhook — electronically variable active damping system (hardware and sport setup)	—	●	●	—
Space-saver spare wheel	—	○	○	—
<b>EXTERIOR</b>				
Front grille with vertical grille bars in black, side ornamental grilles (black mesh)	○	●	●	●
Trident on front grille and Saetta logo on C-pillar with red accents	—	●	●	—
Sport front bumper with integrated parking sensors	—	●	●	—
Integrated rear lip spoiler	—	●	●	—
Sideskirts — Trofeo Design	—	●	●	●
Shadow Line exterior trim	—	●	●	●
Electrically adjustable and heated exterior mirrors	●	●	●	●
Dual oval pipe exhaust system in black-painted stainless steel with electronically-controlled bypass valves	○	●	●	—

● STANDARD ○ OPTIONAL — NOT AVAILABLE

	GT	GT SPORT MC Shift	GT SPORT MC Auto Shift	GT MC Stradale
Lightweight boot lid construction, with remote key opening	●	●	●	●
Taillamps with LED technology and fumè-look lens	—	●	●	●
Metallic paint	○	○	○	○
Special paint	○	○	○	○
Special matt-finish paint	○	○	○	○
Pearlescent paint — Bianco Fuji	—	○	○	○
Pearlescent paint — Bianco Birdcage	—	○	○	○
Pearlescent paint — Grigio Lava	—	○	○	○
Car cover	○	○	○	○
Exterior Chrome Pack	—	○	○	—
Front bumper integrated with braking system air ducts and aerodynamic splitter plus undertray	—	—	—	●
<b>INTERIOR</b>				
Folding front armrest with illuminated storage compartment	●	●	●	●
Folding rear armrest	●	●	●	●
Dark Chrome or Eco Chrome interior trim	●	●	●	—
Selected interior details in leather colour	●	●	●	●
Front passenger seat lumbar functionality	●	●	●	●
Trofeo Design Active Shifting gearshift paddles	○	●	●	●
Maserati clock design in central dashboard with chrome-plated trim	●	●	●	●
Fabric headlining	●	●	●	●
Smokers' Package	●	●	●	●
Three-spoke, multifunction sports steering wheel — black, full leather	●	●	●	●
Sportier seats with integrated headrests, front and rear	—	●	○	●
Poltrona Frau® leather/drilled Alcantara® upholstery	—	●	○	●
Full-leather interior	—	○	●	○
Perforated leather for front and rear seats (seat squab and backrest centres)	○	○	○	○
Alcantara® Pack (central armrest and dashboard area, door panel armrest and handles, and tunnel gear surround)	—	○	○	●
Seat backrest cover in black	—	●	●	●
Seat backrest cover to match colour of leather seats	—	○	○	○
Trident logo embossed on head restraints	●	●	●	—
Alcantara® headlining (Beige, Pearl Beige, Grigio, Nero, Blu Trofeo)	○	○	○	○
Interior Centennial Pack I (leather interior with strip design in contrasting colour on front and rear seats, central and side armrests, and rear armrest)	—	○	○	—
Titanium-look fibre (TitanTex) on selected interior details	—	○	○	○
Wood trim on selected interior details — Rosewood	○	○	○	—
Wood trim on selected interior details — Wengè	○	○	○	—
Trim on selected interior details — Walnut Briarwood	○	○	○	—
Wood trim on selected interior details — Padouk	○	○	○	—
High-gloss colour for selected interior details	○	○	○	○
Steering wheel — coloured leather	○	○	○	○

**MASERATI GRANTURISMO RANGE** Standard and Optional Equipment

	GT	GT SPORT MC Shift	GT SPORT MC Auto Shift	GT MC Stradale
Steering wheel — Black leather and Alcantara®	—	○	○	○
Steering wheel — coloured leather and Alcantara®	○	○	○	○
Steering wheel — wood trim and gear knob in black leather	○	○	○	—
Steering wheel — coloured leather and wood trim (gear knob included)	○	○	○	—
Stitching colour upon request (steering wheel excluded)	○	○	○	○
Trident logo stitched on head restraints (same colour as stitching colour)	○	○	○	●
Stitching colour upon request for Alcantara® areas	—	○	○	○
Dashboard and rear shelf in coloured leather	○	○	○	○
Dual-colour interior	○	○	○	○
Carpet piping colour upon request	○	○	○	○
Interior carpet colour upon request	○	○	○	○
TitanTex sills	—	○	○	○
Two individual full-size cup holders for front and rear passengers	●	●	●	●
Lightweight sport pedals	○	●	●	●
Pedals with black plastic cover	●	○	○	—
Nero Soft on selected interior details	—	—	—	●
<b>COMFORT AND FUNCTIONALITY</b>				
Alarm system (perimeter and volumetric sensing, anti-lift device, electronic immobilizer)	●	●	●	●
Automatic headlamp activation	●	●	●	●
Cruise Control	●	●	●	●
Dual-zone automatic climate control with two rear air outlets	●	●	●	●
Electric opening assist for boot lid and doors	●	●	●	●
Electronic Parking Brake (EPB)	●	●	●	●
Front parking sensors	●	●	●	—
Rear parking sensors	●	●	●	●
Maserati high-fidelity sound system	●	●	●	●
Maserati Multimedia System with 7-inch in-dashboard screen (navigation system, RDS tuner, single-CD player, 30GB hard-disc drive, voice control, Bluetooth®, USB and AUX-IN)	●	●	●	●
Power-assisted steering, with speed-sensitive feature	●	●	●	●
Rain sensor	●	●	●	●
Remote key (alarm system on/off, doors lock/unlock, boot lid unlock)	●	●	●	●
Digital RPM indicator	●	●	●	●
Sport mode setting via Sport button (affecting gear change, accelerator response, Maserati Stability Program (MSP) system, exhaust bypass valves and Skyhook suspension setting)	●	●	●	●
Tyre sealing compound and electric air compressor	●	●	●	●
Air bag system (front, side, window)	●	●	●	●
Bi-xenon headlamps with integrated Daytime Running Lamps (DRLs) LED lights and headlamp washing system	●	●	●	●
Headlamps — Steel-look (white side mark)	○	●	●	○
Headlamps — Matt Black-look (white side mark)	○	○	○	●
Headlamps — Matt Grey-look (white side mark)	●	○	○	—

● STANDARD   ○ OPTIONAL   — NOT AVAILABLE

	GT	GT SPORT MC Shift	GT SPORT MC Auto Shift	GT MC Stradale
Front seat belts with pretensioners and load limiters	●	●	●	●
Rear seat belts with pretensioners	●	●	●	●
Maserati Stability Program (MSP)	●	●	●	●
Adaptative light control system	●	●	●	●
Steering wheel with manual height and reach adjustments	●	●	●	●
Automatically dimming interior rearview mirror	●	●	●	●
Automatically dimming rearview exterior mirrors	○	○	○	○
HomeLink® — garage door opener	○	○	○	○
Bose® Surround Sound System	○	○	○	○
iPod® interface	○	○	○	○
Comfort Pack front seats (heating, driver's seat memory)	○	○	○	○
Tyre Pressure Monitoring System (TPMS)	○	○	○	○
Fog lamps	●	—	—	—

#### MC SPORT LINE

Aerodynamic Package in Carbon Fibre I (carbon-finish front splitter, rear-lip spoiler, side mirrors and door handles)	○	○	○	○
Aerodynamic Package in Carbon Fibre II (carbon-finish under door moulding, exhaust pipes and rear bumper aerodynamic fins)	—	○	○	—
Trofeo Package, includes: light alloy wheels — 20-inch Trofeo-Design Machine-Polished finishing; carbon fiber hood in body color	—	○	○	—
Interior Carbon Package — Evolution I (door entry guards in carbon fibre with MC Sport Line logo, carbon fibre centre console)	○	○	○	○
Interior Carbon Package — Evolution II (Carbon Fibre shift paddles, carbon fibre instrument surround and MC Stradale graphic design)	○	○	○	○
Interior Carbon Package — Evolution IV (seat frame and back rest cover in carbon fibre)	—	○	○	○
Carbon finish on dash and door panel trim strips	○	○	○	○
Electro-actuated switch controls in Carbon Fibre	—	○	—	○
Steering wheel — Carbon finish and Black leather	○	○	○	○
Steering wheel — Carbon finish and coloured leather	○	○	○	○
MC Design aluminum driving pedals (including foot rest)	○	○	○	○
20-inch Gloss Black Neptune Design alloy wheels (8.5J x 20" front; 10.5J x 20" rear)	—	○	○	○
Handling Pack (stiffer suspension setup with 10 mm lower rider height, revised MSP software, grooved and drilled brake discs)	—	○	—	—
Single-rate suspension with sport setup	—	—	○	—

**MASERATI GRANTURISMO MC CENTENNIAL EDITION**  
Standard and Optional Equipment

**GT MC Stradale  
Centennial Ed.**

**ENGINE AND TRANSMISSION**

Engine V8 4.7 L max power 460 CV; max torque 520 N•m	●
MC Shift 6-speed electro-actuated transmission	●

**WHEELS AND CHASSIS**

20-inch MC Design in Charcoal (white/red/blue)	●
20-inch Trofeo-Design in Matt Smoke	○
Specific high-performance tyres	●
Space-saver spare wheel	○
CCM (Ceramic Composite Material) front 380 mm perforated brake discs with 6-piston calipers; rear 360 mm drilled brake discs with 4-piston calipers	●
Brake calipers, painted — Black	○
Brake calipers, painted — Red	○
Brake calipers, painted — Yellow	○
Brake calipers, painted — Titanium	●
Brake calipers — Anodized Matt Blue	○
Electronic Parking Brake (EPB)	●

**GT MC Stradale  
Centennial Ed.**

**EXTERIOR**

Specific paints for Centennial cars (Rosso Magma, Blu Inchiostro, Grigio Pietra, Bianco Birdcage, Nero Carbonio, Grigio Granito, Bianco Eldorado)	●
Front grille with vertical grille bars in black colour, trident with red accents; lateral port-hole grilles	●
Saetta logo on C-pillar with red accents	●
Headlamps — Black-background, white side-marker reflector	●
Dual powered, heated exterior mirrors	●
Shadow Line	●
Carbon fiber hood in body color; interior side in matt carbon fiber	●
Front spoiler integrated with aerodynamic undertray	●
Rear bumper with aerodynamic extractor	●
Front fenders with functional air outlet	●
Additional rear-lip spoiler mounted on the boot lid	●
Rear parking sensors	●
Sport exhaust — Central positioned dual tail pipes, in chrome-plated stainless steel, pneumatic valves controlled via Sport/Race buttons	●
Car cover	○

**INTERIOR**

Aluminium sport pedals	●
MC-design sport instrument cluster	●
Maserati clock design in centre dashboard with chrome-plated trim	●
Maserati Active Shifting (longer shift paddles, Trofeo Design)	●
Sport and Race buttons for Sport mode set up (manual gearshift, accelerator, MSP system, exhaust system, instrument display). MC-R gearshift available in Race mode	●
Steering column with manual height and reach adjustments	●
Comfort Pack, front seats (heating, driver's seat memory, power steering column with easy entry/exit function)	○
Stitched Trident in the headrests	●

**GT MC Stradale  
Centennial Ed.**

**UPHOLSTERY AND TRIMS**

Fabric headliner	●
Alcantara® headlining	○
Black floor mats with coloured piping	●
Sportier seats with integrated headrests, front and rear	●
Centennial interior — Nero/Rosso Corallo strip	●
Centennial interior — Bianco Pregiato/Blu Santorini strip	●
Centennial interior — Nero/Bianco Pregiato strip	●
Centennial interior — Nero/Blu Santorini strip	●
Leather interior with strip design in contrast color on front and rear seats, central and lateral armrests and rear armrest	●
Strip in coloured leather	●
Perforated leather (squab and backrest)	○
Seat backrest cover — Black	●
Seat backrest cover — Same colour of the seats	○
Interior trim — Nero Soft	●
Leather steering wheel with strip design in contrast color and contrast stitching	●
Stitching in specific colour	●
Upper/lower dashboard and rear shelf in black colour	●

**SAFETY**

Tyre Pressure Monitoring System (TPMS)	●/○
--	-----

**ELECTRONIC DEVICES**

Automatically dimming rearview — interior mirror	●
Automatically dimming rearview — exterior mirrors	○
HomeLink®	○
Bose® Surround Sound System	○
Maserati Multimedia System with 7-inch in-dashboard screen — includes navigation system, RDS tuner, single-CD player, 30GB hard-disc drive, voice control HW 8.0 (Bluetooth®) with USB and AUX-IN	●
iPod® connection	○

**GT MC Stradale  
Centennial Ed.**

**MC SPORT LINE**

Aerodynamic Package in carbon fiber (rear lip spoiler and side mirrors in carbon fiber, door handles in carbon finish)	●
Interior carbon package (paddle shift in carbon fiber, instrument surround, MC Stradale graphic design and centre console in carbon fiber)	○
Carbon-finish interior trim	●
Electro-actuated switch controls in carbon fiber	○
Steering wheel in carbon finish/black leather	○
Seat backrest cover in carbon fibre	○
Carbon fiber hood (carbon look)	○
Seat frame in carbon fibre	●
Carbon fibre door sills with model and Centennial logo	●
MC Design aluminum driving pedals (including dead pedal)	○
Double-wishbone single damping suspension with stiffer MC setup and high lowered ride	●



## PERSONALISATION

---

### A PERSONALISATION PROGRAMME LIKE NO OTHER

---

Maserati cars have a personalisation programme like no other to enable every customer to tailor their car as they see fit and ensure complete exclusivity. The GranCabrio can be made truly individual with a fabric soft top that is available in six colours, and two colour options for the Poltrona Frau® leather upholstery. Pearl Beige and Profondità Blue have been developed to provide elegant, attractive combinations with the exterior colours and soft top. The optional Shadow Line trim gives the GranCabrio's exterior an even more aggressive look, with a number of items in black instead of chrome-plated. These include the radiator grille fillets, the three signature air vents behind the front wheel, the exhaust tailpipes and the line that runs around the interior. The front lamp assemblies receive a striking matt black finish, as well. The moldings of the dashboard, door panels and rear side panels are available in the new colours: Dark Chrome, which combines Anthracite Grey with warm tones, or Eco Chrome, which evokes the glow of molten metal. As options, the customer can choose between two lacquered colours: Blue Laque or Black Piano; or four luxury

woods: Rosewood, Burr Walnut, Polished Wengé or Padouk. On a car like this, it is the details that make the difference. So even the carpets can be customised by choosing the colour of the rims from a selection of seven different shades: Black, Blue, Bordeaux, Grey, Brown, Red and Sand. Then there are three types of alloy wheel in Silver or Mercury Grey and no fewer than eight brake caliper colours.

## MASERATI GRANCABRIO RANGE

GranCabrio

### DIMENSIONS

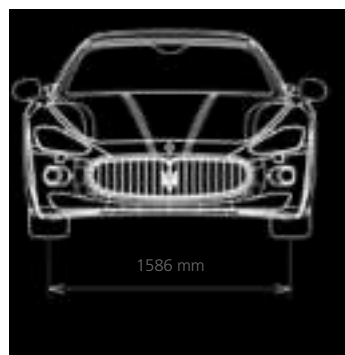

### GRANCABRIO

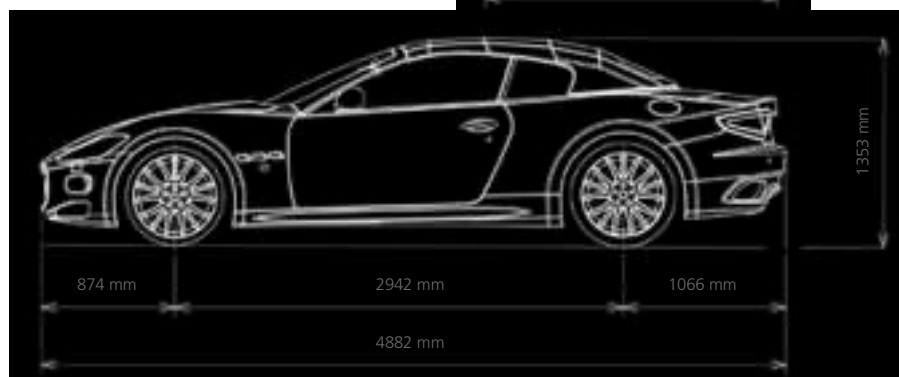
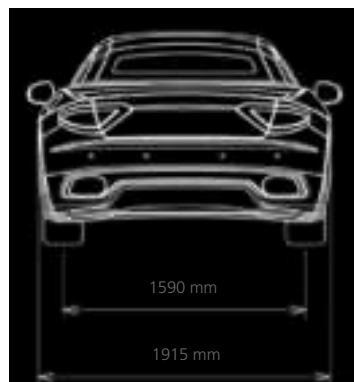

### DIMENSIONS AND WEIGHTS

Length	4882 mm
Width (with side mirrors)	2056 mm
Width (without side mirrors)	1915 mm
Height	1353 mm
Wheelbase	2942 mm
Dry weight (EU version)	1887 kg
Kerb weight (EU version)	1980 kg
Boot capacity	173 l
Fuel tank capacity	75 l
Weight distribution	49% front — 51% rear (with soft top closed) 48% front — 52% rear (with soft top opened)
Turning circle	12.3 m

### TYRES

Front tyres	245/35 ZR20
Rear tyres	285/35 ZR20

### ENGINE

Number of cylinders and layout	V8 90°
Displacement	4691 cc
Compression ratio	11.25:1

### PERFORMANCE

Max power output	450 HP (323 kW)
Engine speed at max power output	7000 rpm
Peak torque	510 Nm (52 kgm)
Engine speed at peak torque	4750 rpm
Maximum speed (km/h)	285 (185 mph) MC Auto Shift
Acceleration 0 – 100 km/h	5.2 s
Braking distance from 100 – 0 km/h	35 m

### CONSUMPTION AND EMISSIONS

Fuel consumption - urban cycle (l/100 km)	22.5 (12.5 mpg)
Fuel consumption - extra urban cycle (l/100 km)	9.8 (28.8 mpg)
Fuel consumption - combined cycle (l/100 km)	14.5 (19.5 mpg)
CO <sub>2</sub> emissions - combined cycle (g/km)	337
Regulation	Euro 6



Yellow

Red

Blue

Anodized Matt Blue

Titanium

Silver

Black

Anodized Matt Red



**BIRDCAGE  
SILVER**

\* Front tyre: 8.5J x 20"  
\* Rear tyre: 10.5J x 20"



**BIRDCAGE  
GRIGIO MERCURY**

\* Front tyre: 8.5J x 20"  
\* Rear tyre: 10.5J x 20"



**TRIDENT DESIGN  
SILVER**

\* Front tyre: 8.5J x 20"  
\* Rear tyre: 10.5J x 20"



**TRIDENT DESIGN  
GRIGIO MERCURY**

\* Front tyre: 8.5J x 20"  
\* Rear tyre: 10.5J x 20"



**NEPTUNE DESIGN  
SILVER**

\* Front tyre: 8.5J x 20"  
\* Rear tyre: 10.5J x 20"



**NEPTUNE DESIGN  
GRIGIO MERCURY**

\* Front tyre: 8.5J x 20"  
\* Rear tyre: 10.5J x 20"

## MASERATI GRANCABRIO RANGE

GranCabrio Sport

### DIMENSIONS

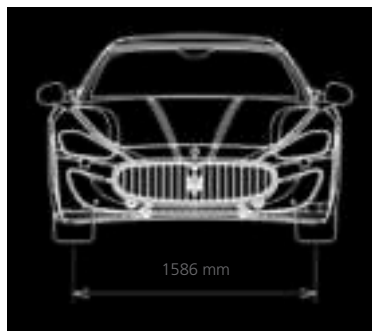

### GRANCABRIO SPORT

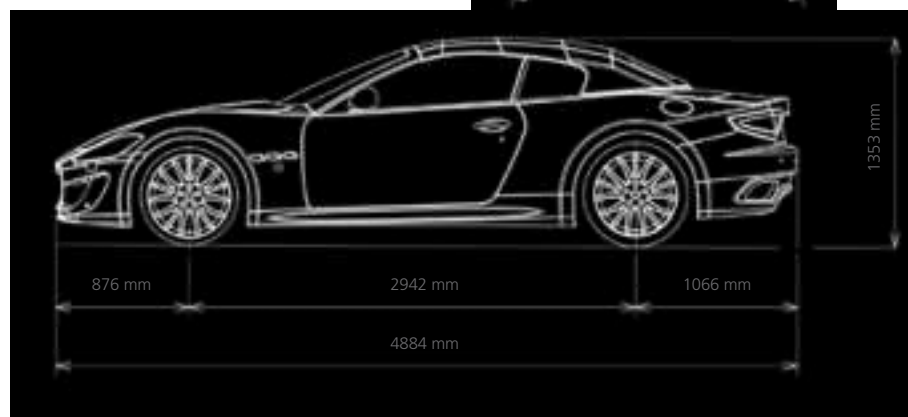
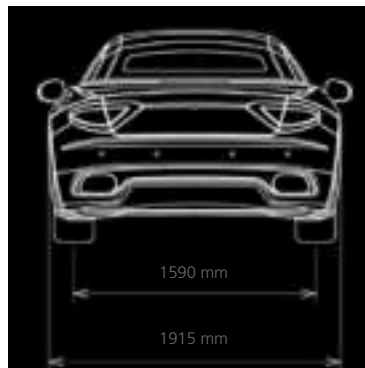

### DIMENSIONS AND WEIGHTS

Length	4881 mm
Width (with side mirrors)	2056 mm
Width (without side mirrors)	1915 mm
Height	1343 mm
Wheelbase	2945 mm
Dry weight (EU version)	1887 kg
Kerb weight (EU version)	1980 kg
Boot capacity	173 l
Fuel tank capacity	75 l

Weight distribution

Turning circle

### TYRES

Front tyres	245/35 ZR20
Rear tyres	285/35 ZR20

### ENGINE

Number of cylinders and layout	V8 90°
Displacement	4691 cc
Compression ratio	11.25:1

### PERFORMANCE

Max power output	460 HP (338 kW)
Engine speed at max power output	7000 rpm
Peak torque	520 Nm (53 kgm)
Engine speed at peak torque	4750 rpm
Maximum speed (km/h)	285 (177 mph) soft top closed
Acceleration 0 – 100 km/h	5.0 s
Braking distance from 100 – 0 km/h	35 m

### CONSUMPTION AND EMISSIONS

Fuel consumption - urban cycle (l/100 km)	22.5 (12.5 mpg)
Fuel consumption - extra urban cycle (l/100 km)	9.8 (28.8 mpg)
Fuel consumption - combined cycle (l/100 km)	14.5 (19.5 mpg)
CO <sub>2</sub> emissions - combined cycle (g/km)	337
Regulation	Euro 6

### GRANCABRIO SPORT

49% front — 51% rear (with soft top closed)
48% front — 52% rear (with soft top opened)
12.3 m



Polished Aluminum Yellow Red Blue Anodized Matt Blue Titanium Silver Black Anodized Matt Red



**ASTRO DESIGN  
SILVER (S)**

\* Front tyre: 8.5J x 20"  
\* Rear tyre: 10.5J x 20"



**ASTRO DESIGN  
SHINY ANTRACITE GREY**

\* Front tyre: 8.5J x 20"  
\* Rear tyre: 10.5J x 20"



**BIRDCAGE  
SILVER**

\* Front tyre: 8.5J x 20"  
\* Rear tyre: 10.5J x 20"



**BIRDCAGE  
GRIGIO MERCURY**

\* Front tyre: 8.5J x 20"  
\* Rear tyre: 10.5J x 20"



**TRIDENT DESIGN  
SILVER**

\* Front tyre: 28.5J x 20"  
\* Rear tyre: 10.5J x 20"



**TRIDENT DESIGN  
GRIGIO MERCURY**

\* Front tyre: 8.5J x 20"  
\* Rear tyre: 10.5J x 20"



**MC DESIGN  
TITANIO**

\* Front tyre: 8.5J x 20"  
\* Rear tyre: 10.5J x 20"



**MC DESIGN GRAFITE  
MATT (FORGED)**

\* Front tyre: 8.5J x 20"  
\* Rear tyre: 10.5J x 20"



**NEPTUNE DESIGN  
SILVER**

\* Front tyre: 8.5J x 20"  
\* Rear tyre: 10.5J x 20"



**NEPTUNE DESIGN  
GRIGIO MERCURY**

\* Front tyre: 8.5J x 20"  
\* Rear tyre: 10.5J x 20"



**NEPTUNE DESIGN  
BLACK**

\* Front tyre: 8.5J x 20"  
\* Rear tyre: 10.5J x 20"

## MASERATI GRANCABRIO RANGE

GranCabrio MC

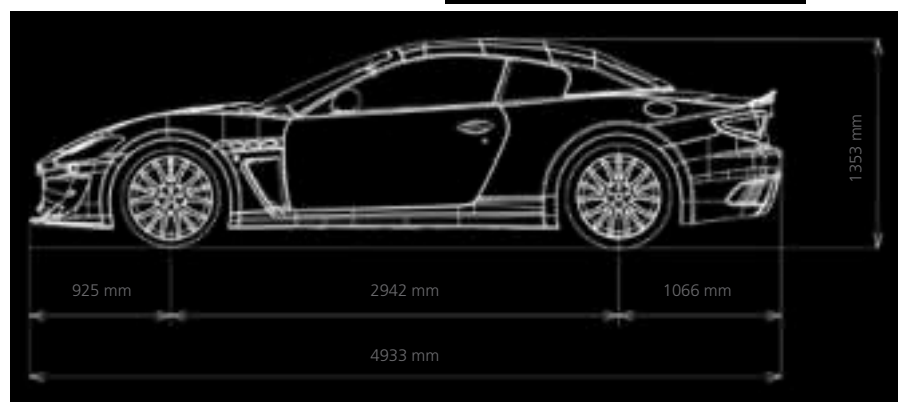
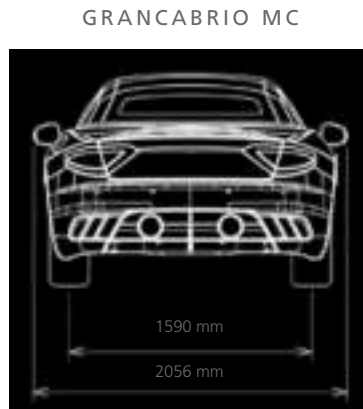

## DIMENSIONS AND WEIGHTS

Length
Width (with side mirrors)
Width (without side mirrors)
Height
Wheelbase
Dry weight (EU version)
Kerb weight (EU version)
Boot capacity
Fuel tank capacity

Weight distribution

Turning circle

## TYRES

Front tyres
Rear tyres

## ENGINE

Number of cylinders and layout
Displacement
Compression ratio

## PERFORMANCE

Max power output
Engine speed at max power output
Peak torque
Engine speed at peak torque
Maximum speed (km/h)
Acceleration 0 – 100 km/h
Braking distance from 100 – 0 km/h

## CONSUMPTION AND EMISSIONS

Fuel consumption - urban cycle (l/100 km)
Fuel consumption - extra urban cycle (l/100 km)
Fuel consumption - combined cycle (l/100 km)
CO <sub>2</sub> emissions - combined cycle (g/km)
Regulation

## GRANCABRIO MC

4933 mm
2056 mm
1915 mm
1343 mm
2942 mm
1880 kg
1973 kg
173 l
75 l
49% front — 51% rear (with soft top closed)
48% front — 52% rear (with soft top opened)
10.7 m

245/35 ZR20
285/35 ZR20

V8 90°
4691 cc
11.25:1

460 HP (338 kW)
7000 rpm
520 Nm (53 kgm)
4750 rpm
289 (179 mph) soft top closed
4.9 s
35 m

22.5 (12.5 mpg)
9.8 (28.8 mpg)
14.5 (19.5 mpg)
337
Euro 6



Polished Aluminum

Yellow

Red

Blue

Anodized Matt Blue

Titanium

Silver

Black

Anodized Matt Red



**MC DESIGN  
TITANIO**

\*Front tyre: 8.5J x 20"  
\*Rear tyre: 10.5J x 20"



**MC DESIGN GRAFITE  
MATT (FORGED)**

\*Front tyre: 8.5J x 20"  
\*Rear tyre: 10.5J x 20"



**NEPTUNE DESIGN  
SILVER**

\*Front tyre: 8.5J x 20"  
\*Rear tyre: 10.5J x 20"



**NEPTUNE DESIGN  
GRIGIO MERCURY**

\*Front tyre: 8.5J x 20"  
\*Rear tyre: 10.5J x 20"



**NEPTUNE DESIGN  
BLACK**

\*Front tyre: 8.5J x 20"  
\*Rear tyre: 10.5J x 20"

**MASERATI GRANCABRIO RANGE**  
GranCabrio MC Centennial Edition

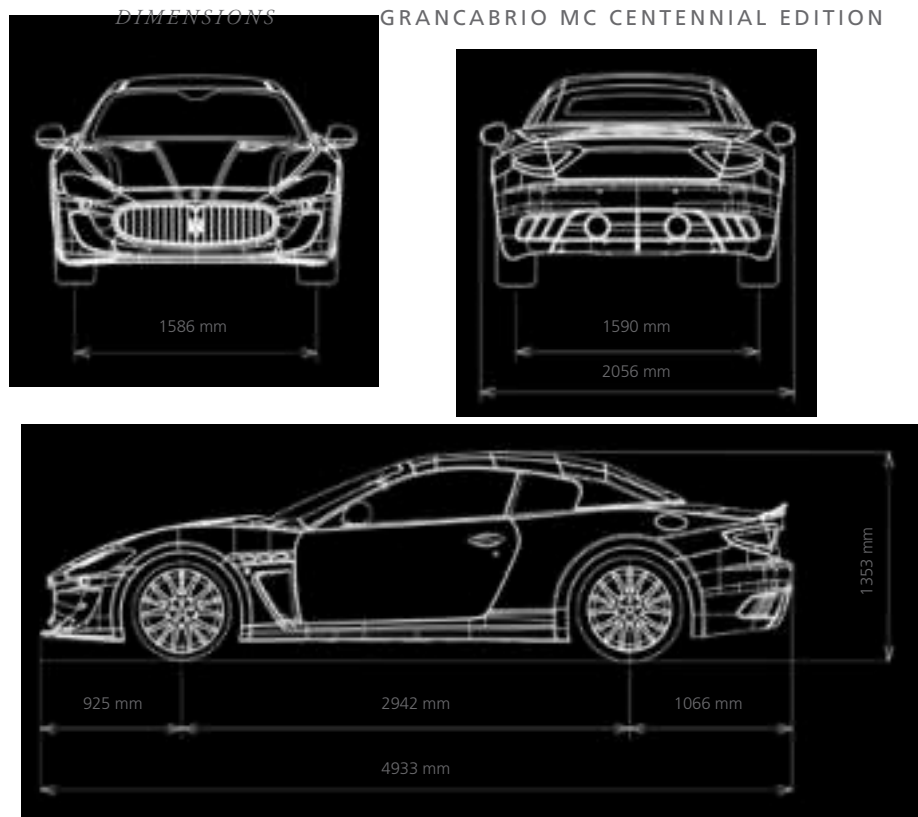

**DIMENSIONS AND WEIGHTS**

Length	4933 mm
Width (with side mirrors)	2056 mm
Width (without side mirrors)	1915 mm
Height	1343 mm
Wheelbase	2942 mm
Dry weight (EU version)	1880 kg
Kerb weight (EU version)	1973 kg
Boot capacity	173 l
Fuel tank capacity	75 l

Weight distribution

Turning circle

**TYRES**

Front tyres	245/35 ZR20
Rear tyres	285/35 ZR20

**ENGINE**

Number of cylinders and layout	V8 90°
Displacement	4691 cc
Compression ratio	11.25:1

**PERFORMANCE**

Max power output	460 HP (338 kW)
Engine speed at max power output	7000 rpm
Peak torque	520 Nm (53 kgm)
Engine speed at peak torque	4750 rpm
Maximum speed (km/h)	289 (179 mph) soft top closed
Acceleration 0 – 100 km/h	4.9 s
Braking distance from 100 – 0 km/h	35 m

**CONSUMPTION AND EMISSIONS**

Fuel consumption - urban cycle (l/100 km)	22.5 (12.5 mpg)
Fuel consumption - extra urban cycle (l/100 km)	9.8 (28.8 mpg)
Fuel consumption - combined cycle (l/100 km)	14.5 (19.5 mpg)
CO <sub>2</sub> emissions - combined cycle (g/km)	337 g/km
Regulation	Euro 6

**GRANCABRIO MC CENTENNIAL EDITION**

Length	4933 mm
Width (with side mirrors)	2056 mm
Width (without side mirrors)	1915 mm
Height	1343 mm
Wheelbase	2942 mm
Dry weight (EU version)	1880 kg
Kerb weight (EU version)	1973 kg
Boot capacity	173 l
Fuel tank capacity	75 l
Weight distribution	49% front — 51% rear (with soft top closed) 48% front — 52% rear (with soft top opened)
Turning circle	12.3 m

Front tyres	245/35 ZR20
Rear tyres	285/35 ZR20

Number of cylinders and layout	V8 90°
Displacement	4691 cc
Compression ratio	11.25:1

Max power output	460 HP (338 kW)
Engine speed at max power output	7000 rpm
Peak torque	520 Nm (53 kgm)
Engine speed at peak torque	4750 rpm
Maximum speed (km/h)	289 (179 mph) soft top closed
Acceleration 0 – 100 km/h	4.9 s
Braking distance from 100 – 0 km/h	35 m

Fuel consumption - urban cycle (l/100 km)	22.5 (12.5 mpg)
Fuel consumption - extra urban cycle (l/100 km)	9.8 (28.8 mpg)
Fuel consumption - combined cycle (l/100 km)	14.5 (19.5 mpg)
CO <sub>2</sub> emissions - combined cycle (g/km)	337 g/km
Regulation	Euro 6



Polished Aluminium

Yellow

Red

Blue

Anodized Matt Blue

Titanium

Silver

Black

Anodized Matt Red



**MC DESIGN CHARCOAL WITH WHITE ACCENTS**

\* Front tyre: 8.5J x 20"  
\* Rear tyre: 10.5J x 20"



**MC DESIGN CHARCOAL WITH RED ACCENTS**

\* Front tyre: 8.5J x 20"  
\* Rear tyre: 10.5J x 20"



**MC DESIGN CHARCOAL WITH BLUE ACCENTS**

\* Front tyre: 8.5J x 20"  
\* Rear tyre: 10.5J x 20"



**TROFEO DESIGN MATT SMOKE**

\* Front tyre: 8.5J x 20"  
\* Rear tyre: 10.5J x 20"

SOLID PAINTS

METALLIC PAINTS

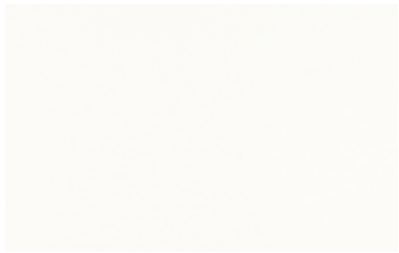

Bianco Eldorado



Bordeaux Pontevecchio



Blu Socratico



Grigio Alfieri



Blu Nettuno



Nero

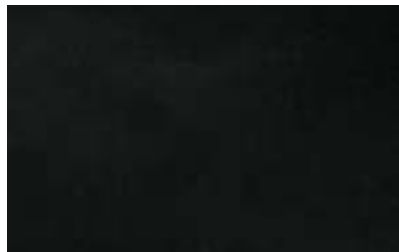

Nero Carbonio



Blu Oceano



Rosso Trionfale



Grigio Touring

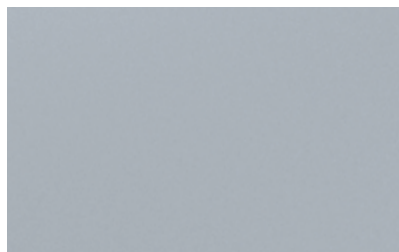

Grigio Pietra



Blu Inchiostro



Rosso Magma

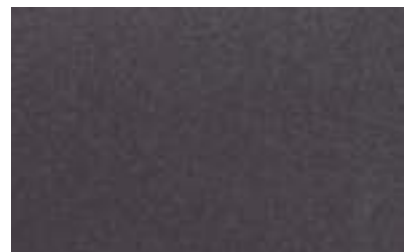

Grigio Granito

**SPECIAL PAINTS**



Giallo Granturismo

**MATT PAINTS**



Blu Mediterraneo



Blu Mediterraneo



Bianco Birdcage



Rosso Mondiale



Grigio Granito

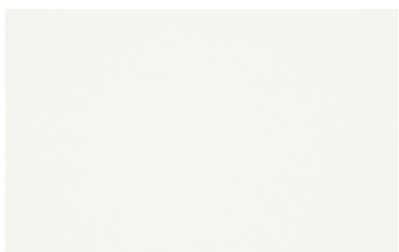

Bianco Fuji



Grigio Lava

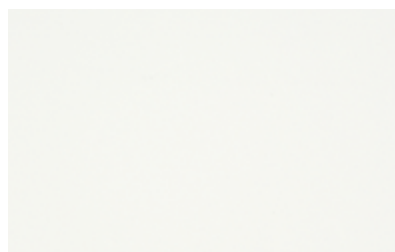

Bianco Fuji

	GC	GC SPORT	GC MC	GC MC 100
<b>SOLID PAINTS</b>				
Bianco Eldorado	●	●	●	●
Nero	●	●	●	
<b>METALLIC PAINTS</b>				
Blu Inchiostro				●
Blu Nettuno	●	●		
Blu Oceano	●	●		
Blu Sofisticato	●	●	●	
Bordeaux Pontevecchio	●	●		
Grigio Alfieri	●	●	●	
Grigio Granito	●	●	●	●
Grigio Pietra				●
Grigio Touring	●	●	●	
Nero Carbonio	●	●	●	●
Rosso Magma				●
Rosso Trionfale	●	●	●	
<b>SPECIAL PAINTS</b>				
Bianco Birdcage	●	●	●	●
Bianco Fuji	●	●	●	
Blu Mediterraneo	●	●	●	
Giallo Granturismo	●	●	●	
Grigio Lava	●	●	●	
Rosso Mondiale	●	●	●	
<b>MATT PAINTS</b>				
Bianco Fuji	●	●	●	
Blu Mediterraneo	●	●	●	
Grigio Granito	●	●	●	

LEATHERS



Pearl Beige

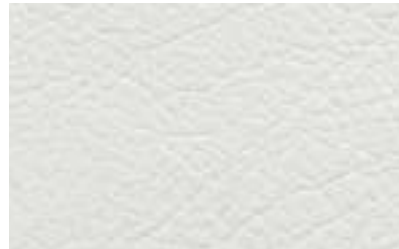

Bianco Pregiato



Sabbia



Cuoio



Bordeaux



Marrone Corniola

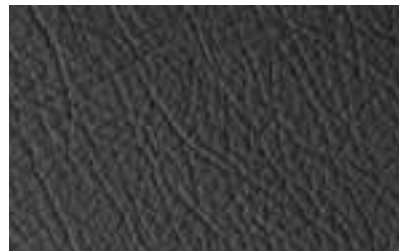

Grigio Chrono



Blu Profondità



Rosso Corallo



Nero

ALCANTARA®

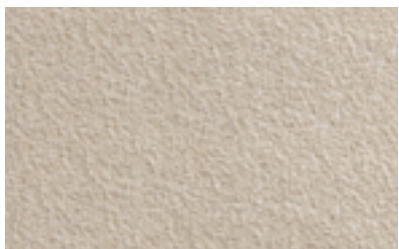

Pearl Beige



Nero



Grigio



Beige



Blu Trofeo

SEAT COLORS	GC	GC SPORT	GC MC	GC MC 100
<b>LEATHERS</b>				
Bianco Pregiato	●	●	●	●
Blu Profondità	●	●	●	
Bordeaux	●	●		
Cuoio	●	●	●	
Grigio Chrono	●	●	●	
Marrone Corniola	●	●		
Nero	●	●	●	●
Pearl Beige	●	●		
Rosso Corallo	●	●	●	
Sabbia	●	●	●	
<b>ALCANTARA®</b>				
Beige		●	●	
Blu Trofeo		●	●	
Grigio		●	●	
Nero		●	●	
Pearl Beige		●	●	

**LEATHERS**



Pearl Beige

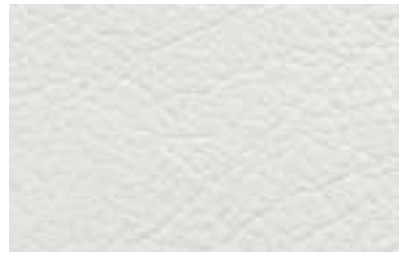

Bianco Pregiato



Sabbia



Cuoio



Bordeaux



Marrone Corniola

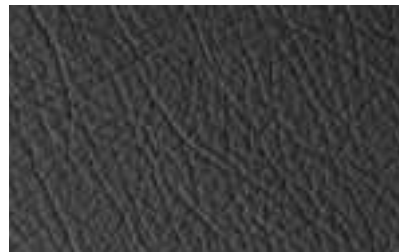

Grigio Chrono



Blu Profondità



Rosso Corallo



Nero

**ALCANTARA®**



Pearl Beige



Nero



Grigio



Beige



Blu Trofeo

**TRIM — METAL**

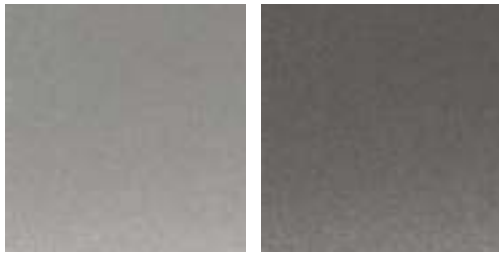

Dark Chrome

Eco Chrome

**TRIM — WOOD**

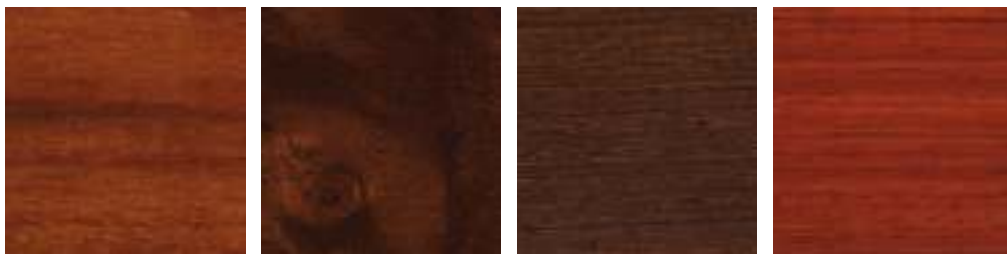

Rosewood

Walnut Briarwood

Wengè

Padouk

**TRIM — FIBER**



Carbon Fiber

**TRIM — HIGH GLOSS**



Black Piano

Blue Laque

	GC	GC SPORT	GC MC	GC MC 100		GC	GC SPORT	GC MC	GC MC 100
<b>DASHBOARD</b>					<b>STEERING WHEEL</b>				
<b>LEATHERS</b>					<b>LEATHERS</b>				
Blu Profondità	●	●	●		Bianco Pregiato	●	●	●	
Bordeaux	●	●			Blu Profondità	●	●	●	
Grigio Chrono	●	●	●		Bordeaux	●	●		
Marrone Corniola	●	●			Cuoio	●	●	●	
Nero	●	●	●	●	Grigio Chrono	●	●	●	
Rosso Corallo	●	●	●		Marrone Corniola	●	●		
					Nero	●	●	●	●
					Pearl Beige	●	●		
<b>DASHBOARD TRIM</b>					<b>ALCANTARA®</b>				
<b>METAL</b>					<b>FIBER</b>				
Dark Chrome	●	●	●	●	Beige	●	●	●	
Eco Chrome	●	●	●	●	Blu Trofeo	●	●	●	
<b>FIBER</b>					<b>WOOD</b>				
Carbon Fiber		●	●	●	Grigio	●	●	●	
<b>WOOD</b>					<b>STEERING TRIM</b>				
Padouk	●	●	●		<b>FIBER</b>				
Walnut Briarwood	●	●	●		Carbon Fiber		●	●	●
Rosewood	●	●	●		<b>WOOD</b>				
Wengè	●	●	●		Padouk	●	●	●	
<b>HIGH GLOSS</b>					<b>STEERING TRIM</b>				
Black Piano	●	●	●		<b>FIBER</b>				
Blue Laque	●	●	●		Carbon Fiber		●	●	●
					<b>WOOD</b>				
					Padouk	●	●	●	
					Walnut Briarwood	●	●	●	
					Rosewood	●	●	●	
					Wengè	●	●	●	
					<b>HIGH GLOSS</b>				
					Black Piano	●	●	●	

CARPETS AND CONTRAST STITCHING

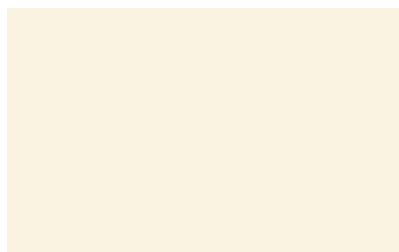

Pearl Beige

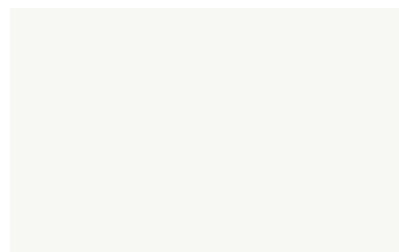

Bianco Pregiato



Beige



Cuoio

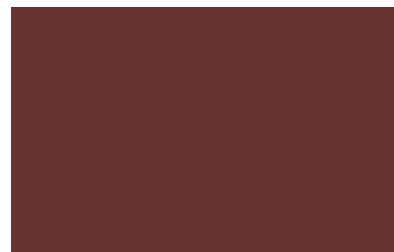

Bordeaux

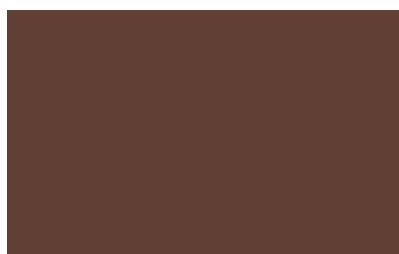

Marrone Corniola



Grigio Chrono



Blu Profondità



Rosso Corallo

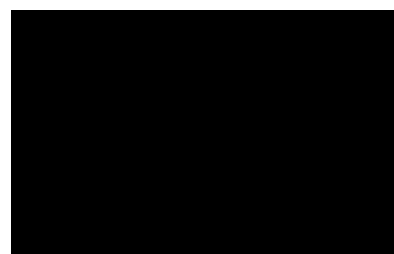

Nero

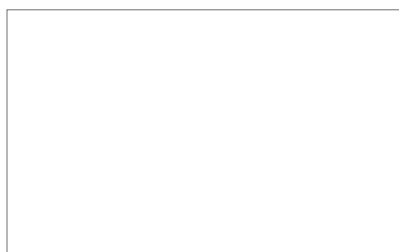

Bianco



Grigio Ghiaccio



Blu Navy



Giallo



Blu Sofisticato

**SEAT BELTS**

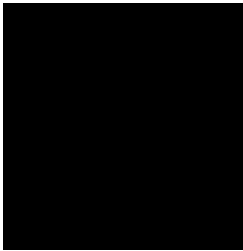

Nero

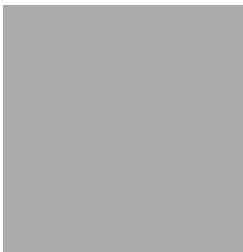

Grigio

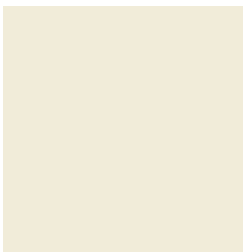

Beige

CARPET	GC	GC SPORT	GC MC	GC MC 100	CONTRAST STITCHING	GC	GC SPORT	GC MC	GC MC 100
<b>COLOR</b>					<b>SEATS</b>				
Bianco Pregiato			●		Bianco	●	●	●	●
Blu Navy	●	●	●		Bianco Pregiato	●	●	●	
Bordeaux	●	●			Blu Navy	●	●	●	
Cuoio	●	●			Blu Sofisticato	●	●	●	●
Grigio Chrono	●	●	●		Bordeaux	●	●		
Marrone Corniola	●	●			Cuoio	●	●	●	
Nero	●	●	●	●	Giallo	●	●	●	
Pearl Beige	●	●			Grigio Chrono	●	●	●	
Rosso Corallo	●	●	●		Grigio Ghiaccio	●	●		
					Marrone Corniola	●	●		
					Pearl Beige	●	●		
					Nero	●	●	●	
					Rosso Corallo	●	●	●	●
					Sabbia	●	●	●	
					<b>SEAT BELTS</b>				
					<b>COLOR</b>				
					Beige	●	●	●	
					Grigio	●	●	●	
					Nero	●	●	●	●

**MASERATI GRANCABRIO RANGE** Standard and Optional Equipment

	GC	GC SPORT	GC MC
<b>WHEELS AND CHASSIS</b>			
19-inch V-style alloy wheels (8.5J x 19" front; 10.5J x 19" rear)	○	○	—
20-inch Titanium-finish MC Design alloy wheels (8.5J x 20" front; 10.5J x 20" rear)	—	○	●
20-inch Silver Neptune-Design alloy wheels (8.5J x 20" front; 10.5J x 20" rear)	○	○	○
20-inch Grigio Mercury Neptune-Design alloy wheels (8.5J x 20" front; 10.5J x 20" rear)	○	○	○
20-inch Matt Graphite finish MC Design forged alloy wheels (8.5J x 20" front; 10.5J x 20" rear)	—	○	○
20-inch Silver Trident Design alloy wheels (8.5J x 20" front; 10.5J x 20" rear)	—	○	—
20-inch Silver Birdcage Design alloy wheels (8.5J x 20" front; 10.5J x 20" rear)	○	○	—
20-inch Grigio Mercury Birdcage Design alloy wheels (8.5J x 20" front; 10.5J x 20" rear)	○	○	—
20-inch Grigio Mercury Trident Design alloy wheels (8.5J x 20" front; 10.5J x 20" rear)	○	○	—
20-inch MC Design alloy wheels (8.5J x 20" front; 10.5J x 20" rear)	—	○	●
20-inch Silver Astro Design alloy wheels (8.5J x 20" front; 10.5J x 20" rear)	○	●	—
20-inch Astro-Design Shiny Antracite Grey alloy wheels (8.5J x 20" front; 10.5J x 20" rear)	○	○	—
20-inch Gloss Black Neptune Design alloy wheels (8.5J x 20" front; 10.5J x 20" rear)	○	○	○
Brake calipers, painted — Silver	○	○	○
Brake calipers, painted — Blue	○	○	○
Brake calipers, painted — Yellow	○	○	○
Brake calipers, painted — Titanium	○	○	○
Brake calipers, painted — Black	●	○	○
Brake calipers, painted — Anodised Matt Red	○	○	○
Brake calipers, painted — Anodised Matt Blue	○	○	○
Brake calipers, painted — Polished Aluminium	○	○	○
Brake calipers, painted — Red	○	●	●
360 mm drilled brake discs — front; 330 mm drilled brake discs — rear	●	—	—
360 mm drilled and slotted brake discs — front; 330 mm drilled and slotted brake discs — rear	—	●	●
Double-wishbone suspension with fixed-rate springs and dampers (MC setup)	—	—	●
18-inch space-saver spare wheel	○	○	○
Skyhook — electronically variable active damping system	●	—	—
Sport Skyhook — electronically variable active damping system (hardware and Sport setup)	—	●	○
<b>EXTERIOR</b>			
Shadow Line exterior trim	—	●	●
Exterior Chrome Pack	—	○	○
Chromeline exterior trim (door handles and doors/capotte moldings in chrome finishing, chrome exhaust pipes)	●	○	—
Front grille — with vertical grille bars in black, side ornamental grilles (black mesh)	○	●	●

● STANDARD   ○ OPTIONAL   — NOT AVAILABLE

	GC	GC SPORT	GC MC
Front grille — with chrome vertical grille bars and Trident with red accents	—	—	○
Front grille — with chrome vertical grille bars and side ornamental grilles (chrome finishing)	●	○	—
MC front bumper with aerodynamic splitter plus undertray	—	—	●
MC rear bumper with aerodynamic extractor	—	—	●
MC front fenders with functional air outlet	—	—	●
Additional rear-lip spoiler in body color, mounted on the boot lid with third stoplamp	—	○	●
Door mirrors — Electrically operated, folding and heated	●	●	●
Exhaust — Twin dual tube tail pipes, pneumatic valves controlled via Sport button	●	—	—
Sport Exhaust — Central dual tube tailpipes Ø 80mm, pneumatic valves controlled via Sport button	—	—	●
Lightweight boot lid construction, with remote key opening	●	●	●
Headlamps — Matt Grey-look (white side mark)	●	○	—
Headlamps — Steel look (white side mark)	○	●	○
Headlamps — Matt Black-look (white side mark)	○	○	●
Headlamps — Matt Silver-look (white side mark)	—	○	—
Metallic paint	○	○	○
Matt paint colours	○	○	○
Special paint	○	○	○
Special paint — Grigio Lava	○	○	○
Special matt-finish paint	○	○	○
Pearlescent paint — Bianco Fuji	○	○	○
Pearlescent paint — Bianco Birdcage	○	○	○
Car cover — GranCabrio designation with top cover in silver color	○	—	—
Car cover — GranCabrio Sport designation with top cover in silver color	—	○	—
Car cover — GranCabrio MC designation with top cover in silver color	—	—	○
Black soft top exterior and interior color	●	●	●
Black soft top exterior color with colored interior	○	○	○
Colored soft top exterior color with colored interior	○	○	○
Exterior Black Pack	○	—	—
Sport front bumper with integrated parking sensors	—	●	—
Integrated front splitter in black colour	—	●	—
Chrome Trident on front grille	●	—	—
Trident with red accents on front grille	—	●	●
Doors and capotte moldings in black finish	○	—	—
Exhaust in black stainless steel	○	—	—
Door handles in body color	○	●	●
Electric opening assist for boot lid and doors	●	●	●

**MASERATI GRANCABRIO RANGE** Standard and Optional Equipment

	GC	GC SPORT	GC MC
Full automatic soft top	●	●	●
Side skirts — Cabrio Design	●	—	—
Side skirts — GTS Design	—	●	—
Sideskirts — Trofeo Design	—	—	●
MC engine hood with air vents (no aesthetic cover underneath)	—	—	●
Trofeo-look carbon fiber hood in body color with air vents (no aesthetic cover underneath)	—	○	○
Rear parking sensors	●	●	●
Front parking sensors	●	●	—
Exhaust in black stainless steel	○	●	—
Exhaust in chrome stainless steel	●	—	●
<b>INTERIOR</b>			
Folding front armrest with illuminated storage compartment	●	●	●
Selected interior details — Dark Chrome	●	●	●
Selected interior details — Eco Chrome (air conditioner, NIT, door handles, headrest, seat belts)	●	●	●
Fixed rear armrest	●	●	●
Aluminum Sport pedals	○	●	●
Maserati Active Shifting shift paddles	●	—	—
Maserati Active Shifting (Trofeo Design)	○	●	●
Maserati clock design in centre dashboard with chrome-plated trim	●	●	●
Dashboard and rear shelf in coloured leather/Benova® (plastic parts in colour — 4 colours)	○	○	○
Sports seats with integrated headrests and clothes hook on the backrest	—	●	●
Three-spoke, multifunctional sports steering wheel — black, full leather	●	●	○
Trident logo embossed on head restraints — front and rear	●	●	●
Trident logo stitched on head restraints — front and rear (same color as STC3)	○	○	○
Poltrona Frau® leather upholstery	●	●	○
Poltrona Frau® drilled leather for central seat areas	○	○	○
Poltrona Frau® leather/drilled Alcantara® upholstery	—	○	●
Poltrona Frau® dual interior colour — door panels, central tunnel and quarter panels, handmade	○	○	○
Seat backrest cover in black	—	●	●
Seat backrest cover same colour as the seats	—	○	○
Seat backrest cover in carbon fibre	—	○	○
Upper/lower dashboard, A-pillar and tonneau cover colour upon request	○	○	○
Dual-colour interior	○	○	○
Carpet colour upon request	○	○	○
Carpet piping upon request	○	○	○

● STANDARD   ○ OPTIONAL   — NOT AVAILABLE

	GC	GC SPORT	GC MC
Stitching colour upon request — steering wheel and gear knob excluded (combined with DRL3, the central seat area will not have contrast stitching)	○	○	○
Stitching colour upon request — For Alcantara® areas	—	○	○
Colour upon request for steering wheel leather details (Alcantara® rim)	—	○	○
Steering wheel — Black leather/Alcantara®	—	○	○
Steering wheel — Wood trim and gear knob in black leather	○	○	○
Steering wheel — Wood trim and coloured leather (gear knob included)	○	○	○
Steering wheel — Alcantara® and coloured leather	—	○	○
Steering wheel — Coloured leather	○	○	○
Wood trim on selected interior details — Rosewood	○	○	○
Wood trim on selected interior details — Wengè	○	○	○
Wood trim on selected interior details — Walnut Briarwood	○	○	○
Wood trim on selected interior details — Padouk	○	○	○
High-gloss colour for selected interior details	○	○	○
Electric soft top opening button	●	●	●
Alcantara® Pack (cluster, central armrest, rear armrest, central tunnel pillow, door panel armrests/handles, central dashboard area, tunnel gear pod)	—	○	●
Leather interior with strip design in contrast color on front and rear seats, central/side, front/rear armrests	—	○	—
Insert in coloured leather	—	○	—
Stitching layout on the seats, M-design	●	—	—
GranCabrio badge in dash on passenger side	●	—	—
GranCabrio Sport badge in dash on passenger side	—	●	—
GranCabrio MC badge in dash on passenger side	—	—	●
Instrument dials in black color with white graphics (ISO MC Stradale)	—	—	●
Aluminium sill protectors with Maserati designation	●	●	●
Instrument dials in Maserati Blu color with white graphics	●	●	—
Sport button for Sport mode setup — gearbox, accelerator throttle, Maserati Stability Program (MSP) system, exhaust system	●	—	—
Sport button for Sport mode setup — gearbox, accelerator throttle, MSP system (exhaust system exhaust valves always open in Sport mode)	—	●	●
Steering column with power height and reach adjustments	○	○	○
Comfort Pack front seats (heating, driver's seat memory)	○	○	○
12-volt plug	●	●	●
Lockable, illuminated glove compartment on passenger side — in dashboard	●	●	●
Storage compartment in centre tunnel — front	●	●	●
Two air outlets — rear	●	●	●
Rear lateral dimming lights	●	●	●
Electric soft top opening button	●	●	●
Electric soft top opening from door key or remote control	●	●	●

**MASERATI GRANCABRIO RANGE** Standard and Optional Equipment

	GC	GC SPORT	GC MC
<b>COMFORT AND FUNCTIONALITY</b>			
Front-passenger seat lumbar functionality	●	●	●
Electrically adjustable front seats with high lateral support	●	●	●
Sport mode setting via Sport button (affecting gear change, accelerator response, Maserati Stability Program (MSP) system, exhaust valves)	●	●	●
Maserati Multimedia System with 7-inch in-dashboard screen — includes navigation system, RDS tuner, single-CD player, 30GB hard-disc drive, voice control HW 8.0 (Bluetooth®) with USB and AUX-IN	●	●	●
Maserati Multimedia System with 7" in dashboard screen — includes navigation system, RDS tuner, single-CD player, 30GB hard-disc drive, voice control HW 8.1 (Bluetooth® plus iPod®) with USB and AUX-IN	○	○	○
Alarm system (perimeter and volumetric sensing, anti-lift device, electronic immobiliser)	●	●	●
Bi-xenon headlamps with headlamp-washing system (integrated DRL LED lamps)	●	●	●
Ambient lights	●	●	●
Automatic headlamp activation	●	●	●
Cruise Control	●	●	●
Dual-zone automatic climate control with two rear air outlets in centre tunnel	●	●	●
Active roll over bars	●	●	●
Electric opening assist for boot lid and doors	●	●	●
Electronic Parking Brake (EPB)	●	●	●
Power-assisted steering wheel, with speed-sensitive features	●	●	●
Rain sensor	●	●	●
Adaptive headlamps	●	●	●
Remote key (on/off alarm system, lock/unlock doors, unlock boot lid)	●	●	●
Tyre sealing compound and electric air compressor (fix and go)	●	●	●
Steering column with manual height and reach adjustments	●	●	●
Air bag system (dual-stage front, lateral head-thorax)	●	●	●
Front passenger air bag	●	●	●
Front seat belts with pretensioners and load limiters	●	●	●
Maserati Stability Program (MSP)	●	●	●
Automatically dimming rearview interior mirror	●	●	●
Automatically dimming rearview exterior mirrors	○	○	○
HomeLink® — Universal Garage Door Opener	○	○	○
Maserati high-fidelity loudspeaker system — 6 speakers with 4 x 25-watt RMS integrated equalizer	●	●	●
Bose® Surround Sound system	○	○	○
iPod® connection	○	○	○
Windstop	○	○	○
Pedals with black plastic protection cover	●	○	○
Tyre Pressure Monitoring System (TPMS)	○	○	○

● STANDARD   ○ OPTIONAL   — NOT AVAILABLE

	GC	GC SPORT	GC MC
Two individual full size cup holders — front and rear passengers	●	●	●
Fog lamps	●	—	—
Taillamps with high-visibility LED lights	●	—	—
Taillamps with high-visibility LED lights (fumè-look)	—	●	●
Central stoplamp	●	●	●
Parking light	●	●	●
Child seat ISOFIX attachments, rear	●	●	●
ROPS	●	●	●
Chrome multimedia knobs	●	●	●
Electronic immobiliser	●	●	●
De-mist sensor	●	●	●

#### MC SPORT LINE

MC Auto Shift — gear keeper, downshift double de-clutch, launch control, rpm indicator, sportier accelerator map (exhaust flaps always open in Sport mode).	—	●	●
Aerodynamic Package in carbon fibre — I (carbon finish rear lip spoiler, door mirrors and door handles)	—	○	○
Aerodynamic Package in carbon fiber — II (under door sills in dark look, rear bumper aerodynamic finish)	—	○	—
Aerodynamic Package in carbon fibre — III (20-inch Machine polished Trofeo-design alloy wheels and carbon fibre bonnet in body colour)	—	○	○
Interior carbon Package — Evolution I (carbon fibre door sill plates with “MC Sport Line” logo, carbon fibre centre console)	○	○	○
Interior carbon Package — Evolution II (carbon fibre shift paddles, carbon fibre instrument surround)	○	○	○
Interior carbon Package — Evolution IV (seat frame and back rest cover in carbon fibre)	—	○	○
Trofeo Package — Light alloy wheels, 20-inch Trofeo-design Machine-Polished finish, Carbon fiber hood in body color	—	○	○
Steering wheel in carbon finish/coloured leather, coloured gear area	—	○	○
Steering wheel in carbon finish/black leather, gear area in black	○	○	○
MC design aluminum driving pedals (including dead pedal)	○	○	○
Carbon finish on dash and door panel trim strips	○	○	○
Single-rate suspension with Sport setup, Red springs	—	—	●

**MASERATI GRANCABRIO MC CENTENNIAL EDITION**  
Standard and Optional Equipment

**GC MC**  
**Centennial Ed.**

**ENGINE AND TRANSMISSION**

Engine V8 4.7 L max power 460 CV; max torque 520 N•m	●
MC Auto Shift 6-speed automatic transmission	●

**WHEELS AND CHASSIS**

20-inch MC Design in Charcoal (white/red/blue)	○
20-inch Trofeo-Design in Matt Smoke	●
Space-saver spare wheel	○
Dual-cast front 360 mm perforated and slotted brake discs with 6-piston calipers; rear 330 mm drilled and slotted brake discs with 4-piston calipers	●
Brake calipers, painted — Black	○
Brake calipers, painted — Silver	○
Brake calipers, painted — Red	●
Brake calipers, painted — Blue	○
Brake calipers, painted — Yellow	○
Brake calipers, painted — Titanium	○
Brake calipers — Anodized Matt Red	○
Brake calipers — Polished Aluminum	○
Brake calipers — Anodized Matt Blue	○
Electronic Parking Brake (EPB)	●
Sport Skyhook — electronically variable active damping system	○

**GC MC**  
**Centennial Ed.**

**EXTERIOR**

Specific paints for Centennial cars (Rosso Magma, Blu Inchiostro, Grigio Pietra, Bianco Birdcage, Nero Carbonio, Grigio Granito, Bianco Eldorado)	●
Front grille with vertical grille bars in black colour, trident with red accents; lateral port-hole grilles	●
Headlamps — Black-background, white side-marker reflector	●
Black soft top exterior and interior color	●
Black soft top exterior color with colored interior	○
Colored soft top exterior color with colored interior	○
Dual powered, heated exterior mirrors	●
Shadow Line	●
Carbon fiber hood in body color; interior side in matt carbon fiber	●
Front spoiler integrated with aerodynamic undertray	●
Rear bumper with aerodynamic extractor	●
Front fenders with functional air outlet	●
Additional rear-lip spoiler mounted on the boot lid with third stoplamp	●
Rear parking sensors	●
Sport exhaust — central-positioned dual tail pipes, in chrome-plated stainless steel, pneumatic valves controlled via Sport button	●
Car cover	○

**INTERIOR**

Aluminium sport pedals	●
Pedals with black plastic protection cover	○
MC-design sport instrument cluster	●
Maserati clock design in centre dashboard with chrome-plated trim	●
Maserati Active Shifting (longer shift paddles, Trofeo Design)	●
Sport button for Sport mode setup (manual gearshift, accelerator, Maserati Stability Program (MSP) system, exhaust system, gear keeper, downshift double declutch, launch control)	●
Steering column with manual height and reach adjustments	●
Comfort Pack, front seats (heating, driver's seat memory, power steering column with easy entry/exit function)	○
Stitched Trident in the headrests	●
Windstop	○

**GC MC  
Centennial Ed.**

**UPHOLSTERY AND TRIMS**

Black floor mats with coloured piping	●
Sportier seats with integrated headrests, front and rear	●
Centennial interior — Nero/Rosso Corallo strip	●
Centennial interior — Bianco Pregiato/Blu Santorini strip	●
Centennial interior — Nero/Bianco Pregiato strip	●
Centennial interior — Nero/Blu Santorini strip	●
Leather interior with strip design in contrast color on front and rear seats, central and lateral armrests and rear armrest	●
Strip in coloured leather	●
Perforated leather (squab and backrest)	○
Seat backrest cover — Black	●
Seat backrest cover — Same colour of the seats	○
Interior trim — Dark Chrome or Eco Chrome	●
Leather steering wheel with strip design in contrast color and contrast stitching	●
Stitching in specific colour	●
Upper/lower dashboard A-pillar and tonneau cover in black colour	●

**SAFETY**

Tyre Pressure Monitoring System (TPMS)	●/○
--	-----

**ELECTRONIC DEVICES**

Automatically dimming rearview — interior mirror	●
Automatically dimming rearview — exterior mirrors	○
HomeLink®	○
Ejectable roll bars	●
Bose® Surround Sound System	○
Maserati Multimedia System with 7-inch in-dashboard screen — includes navigation system, RDS tuner, single-CD player, 30GB hard-disc drive, voice control HW 8.0 (Bluetooth®) with USB and AUX-IN	●
iPod® connection	○

**GC MC  
Centennial Ed.**

**MC SPORT LINE**

Aerodynamic package in carbon fiber — I (additional rear lip spoiler in carbon with third stoplamp; side mirrors in carbon fiber; door handles in carbon finish)	●
Interior carbon package (paddle shift in carbon fiber, instrument surround, MC Stradale graphic design and centre console in carbon fiber)	○
Carbon-finish interior trim	●
Steering wheel in carbon finish/black leather	○
Seat backrest cover in carbon fibre	○
Carbon fiber hood (carbon look)	○
Seat frame in carbon fibre	●
Carbon fibre door sills with model and Centennial logo	●
MC Design aluminum driving pedals (including dead pedal)	○
Double-wishbone single damping suspension with stiffer MC setup	●



## WORLD OF MASERATI

# THE MASERATI LEGEND: NEVER RECREATED. RARELY CAUGHT

Maserati was founded as a racing car constructor, and its deepest roots are in the world of competition. After the impressive records set by the MC12, today the Marque's racing spirit lives on in the Maserati Trofeo MC, holding the international single-marque championship for gentleman drivers who wish to compete in the GT class.

### TROFEO MC WORLD SERIES—STYLISH TRACK EXCITEMENT

The Maserati Trofeo MC is one of the most successful international GT racing series. The 2015 season will bring a new intercontinental calendar, with events in Europe, the United States, Japan and China, and a new sporting regulation that will make racing even more competitive and compelling for all the drivers. For more information, visit [www.maseraticorse.com](http://www.maseraticorse.com) or send an email to [TrofeoMaserati@maserati.com](mailto:TrofeoMaserati@maserati.com).

### MASTER MASERATI DRIVING COURSES

It is perhaps the ultimate driving experience: taking to the racetrack in a race-tuned Maserati. A Master Maserati Driving Course places you behind the wheel of all Maserati range models, so that you can learn about performance driving and other techniques.

#### MASTER WARM-UP

The Maserati Master Warm-Up offers the Maserati clientele an initial taste of training in the techniques of racing-circuit driving in high-performance cars, with the support of a very well-qualified, expert staff. It is an opportunity to enter the Maserati world as a privileged guest, starting from the morning visit to the Factory where the brand's unmistakable cars are built and moving on to the Varano de' Melegari circuit, home of the Master courses. It is a whole afternoon of dynamic activities, including several on-circuit driving sessions combined with a car-handling exercise that tests students' driving abilities, which can then be perfected in subsequent course levels.

#### MASTER GT 1 DAY

The one-day Master GT course designed to improve participant personal driving techniques at the wheel of different Maseratis.



This intensive training programme comprises a number of exciting and dynamic sessions in high-performance cars, and is run by highly trained, specialist staff whose aim is to improve every participant's personal driving skills in an environment that is enjoyable and challenging for all.

#### MASTER GT 2 DAYS

An intensive two-days course that focuses on advanced GT driving techniques and safe, yet sporty driving. In a sequence of sessions on the circuit, the driver is taught how to control the car in different simulated road conditions (e.g., quick direction changes, controlled skids and braking techniques). The ultimate aim is to use the lessons learned to maximize the enjoyment of driving a high-performance Maserati.

#### MASTER HIGH PERFORMANCE

The programme of Master High Performance course includes advanced high-speed driving and technically more complex exercises that build upon the fundamental skills acquired in the earlier Master GT courses. The teaching and structure of this course are adapted to the individual needs of the participants, who can improve their driving proficiency through the analysis of Formula 1-type telemetry data.

### MASTER ITALIAN LIFESTYLE EXPERIENCE

This exclusive, five-star event allows Maserati enthusiasts and their companions to experience the very best that Italy has to offer. Along with a series of Maserati racetrack sessions for the driver, both participants enjoy a programme of first-class activities and excursions in two cities steeped in history and culture: Florence and Parma.

### MASTER MASERATI INCENTIVE

The incentive courses last either half a day or a whole day, and include a series of highly stimulating activities. Aside from the thrilling driving sessions on the track, there are practice exercises and competitions that foster team spirit – hence they provide the perfect context for corporate incentive and team-building events.

For information and registration, Master Maserati Secretariat.  
Telephone: +39 0525 551138 – Fax: +39 0525 551140  
E-mail: [info@mastertg.it](mailto:info@mastertg.it) – [www.maserati.com](http://www.maserati.com)

#### **FINANCIAL SERVICES**

Official Maserati dealers will be delighted to provide you with professional guidance on the various payment options available and create a package tailored to your requirements.

#### **FACTORY TOUR\***

Find out where and how the Maserati myth was born. Maserati offers you the opportunity of finding out about its secrets from the inside, through a guided tour of the Modena production plant. Discover how the cars are born, learn their secrets, fully understand their engineering and really feel part of the Maserati family.

#### **MASERATI EXPERIENCE\*\***

For those wishing to combine their factory visit with a little more insight into the company's home city of Modena, Maserati has the perfect solution. Lasting one or more days, the Maserati Experience enables you to get to know the world of Maserati first-hand via a guided tour that allows you to discover Modena, its culture, its history and its fine food.

You can tailor your Maserati experience to your own personal tastes and interests by combining these and a variety of other activities:

- Visit to the Panini Museum and/or Stanguellini Museum (famous motor museums)
- Guided tour of the town
- Guided tour of a traditional balsamic vinegar manufacturer, with tasting

- Guided tour of a winery, with tasting of local wines
  - Cookery school
  - Day at the Modena Golf & Country Club
- ...And much, much more.

#### **MASERATI COLLECTION**

The Maserati Collection of quality leisurewear, goods and branded merchandise has been specially created for those who share the Maserati passion, and who seek to associate with the illustrious marque. Maserati Collection items are available from all Maserati dealers, and from the Maserati Store at the Maserati showroom in Modena. Alternatively, all the articles in the collection can be purchased online at [www.maseratistore.com](http://www.maseratistore.com) and delivered directly to your home.

#### **MASERATI CLUB**

Joining the exclusive Maserati Club means sharing thrills and experiences with other Maserati owners, and being invited to take part in special motoring events all over the world. Drivers of cars from every era can enjoy the pleasure of driving their Maseratis in a calendar of events created especially for Maserati Club members. The Maserati Club provides the link between the past, present and future of the company. For more information, visit [www.maseraticlub.com](http://www.maseraticlub.com)

#### **MASERATI GENUINE ACCESSORIES**

Specially conceived to satisfy our customers' needs, the Maserati genuine accessories are a perfect combination of design and

functionality. The attention to detail, style and quality of each individual accessory reveal the very essence of the Maserati brand, always searching for the perfect balance between comfort and performance. The car covers and car care products are just a few examples of the Cleaning and Care line, designed to preserve the charm of Maserati cars over time. The Safety line includes child seats and the windscreen water-repellent treatment. The range is completed by the Travel line of accessories, which includes the winter tyres and the luggage compartment net, to make the most out of your car. These are just some examples of the several items available, which will make the Maserati driving experience unique for our customers.

#### **MASERATI CLASSICHE**

Created for enthusiasts and owners of vintage Maserati cars, Maserati Classiche is an organisation dedicated to those who wish to engage with the marque's glorious past. The Maserati Classiche range of products includes items that celebrate the company's history: paintings of glorious events, pictures of classic Maseratis, original reproductions of parts catalogues, owners' handbooks and old brochures, clothing, scale models and much, much more. All the latest items can be found on [www.maserati.com](http://www.maserati.com) in the Maserati – Maserati Classic section. Or for more information, email [maserati.classiche@maserati.com](mailto:maserati.classiche@maserati.com).

\* Tours are only arranged by appointment and can be booked through dealers all over the world

\*\* For more information, please contact us by writing to: [maseratiexperience@maserati.com](mailto:maseratiexperience@maserati.com)



---

## A GLORIOUS COLLABORATION OF MAN AND MACHINE

---

It could be said that the world's most intriguing figures are full of contradictions ... which would accurately describe Maserati GranTurismo and GranCabrio. These are vehicles built in one of the oldest and most traditional factories in Italy, but are among the most modern, innovative cars on the road. It all starts at the historic Maserati factory in Viale Ciro Menotti in Modena, Italy. While iconic Maseratis dating back the 1940s have rolled out of its door, this recently modernized facility employs the best of both skilled labor and technological advances to achieve a superior hand-built vehicle. Utilizing proven practices developed through the company's World Class Manufacturing (WCM) system, the plant has a strong culture dedicated to producing the highest-quality cars

possible. Each car is built to order — a document goes with each car to every station at the facility and is signed to ensure that the car is built to the customer's exact personal requirements.



## MANUFACTURING

---

### SOMETHING THIS SPECIAL DESERVES SPECIAL WRAPPING

---

After completion, the GranTurismo and GranCabrio are subjected to all manner of quality- control tests, looking at everything from the integrity of its weather proofing to its handling on different road surfaces. Each car is tested for 50 kilometres on a wide mix of different local roads, including mountains, motorways and city streets. Each one goes through another series of 24 checkpoints before it is checked again by an independent contractor who double-checks the vehicle with a white-glove treatment, wrapping it in a protective covering before it makes its way to the importer — then to the dealer and ultimately, to the customer. It is this kind of care and pride-in-presentation that is second to none.



MASERATI

MASERATI

MASERATI

MASERATI

**EUROPE:**

AUSTRIA  
AZERBAIJAN  
BELGIUM  
BULGARIA  
CYPRUS  
CZECH REPUBLIC  
DENMARK  
ESTONIA  
FRANCE & MONACO  
GEORGIA  
GERMANY  
GREECE  
HUNGARY  
ISRAEL  
ITALY

KAZAKHSTAN  
LITHUANIA  
LUXEMBOURG  
NETHERLANDS  
NORWAY  
POLAND  
PORTUGAL  
ROMANIA  
RUSSIA  
SPAIN  
SWEDEN  
SWITZERLAND  
TURKEY  
UKRAINE  
UNITED KINGDOM

**AFRICA / MIDDLE EAST:**

BAHRAIN  
EGYPT  
INDIA  
JORDAN  
KUWAIT  
LEBANON  
MOROCCO  
OMAN  
QATAR  
SAUDI ARABIA  
SOUTH AFRICA  
UNITED ARAB EMIRATES



**MASERATI CONTACT CENTRE:**

Global - [info@maserati.com](mailto:info@maserati.com) • Italy - 800 008 008 • Switzerland (German) - 0800 837 100 • Switzerland (French) - 0800 837 200 • Switzerland (Italian) - 0800 837 300 • Germany - 0800 810 80 80  
Sweden - 020 798 000 • Norway - 800 180 88 • Austria - 0800 281 888 • France - 0800 908 000 • Poland - 48 22 57047 30 • Principality of Monaco - 800 93 888 • Denmark - 808 880 00



**ASIA / OCEANIA:**

AUSTRALIA  
CHINA  
HONG KONG  
INDONESIA  
JAPAN  
MALAYSIA  
NEW ZEALAND  
PHILIPPINES  
SINGAPORE  
SOUTH KOREA  
TAIWAN  
THAILAND  
VIETNAM

**NORTH AMERICA:**

USA  
CANADA

**CENTRAL / SOUTH AMERICA**

ARGENTINA  
BRAZIL  
CHILE  
COLOMBIA  
DOMINICAN REPUBLIC  
GUATEMALA  
MEXICO  
PUERTO RICO

Belgium (Flemish) - 0800 710 31 • Belgium (French) - 0800 710 30 • Luxembourg - 800 280 00 • Netherlands - 0800 022 42 34 • Spain - 900 996 945 • Portugal - 800 839 103 • Greece - 00800 3912 725 41  
Turkey - 00800 399 090 538 • United Kingdom - 0800 064 6468 • Australia - 1 800 196 941 • Hong Kong - 00 852 2870 8821 • Japan - 0120 965 120





On the Maserati website, at [www.maserati.com](http://www.maserati.com), or through the Maserati Service Network, you may consult the list of telephones that are compatible with the Multi Media System, and their level of compatibility. The illustrations and texts contained in this brochure are based on the information available at the time of production and do not contain a description of specific characteristics of the car by the Constructor. Some models, equipment and accessories may not be available or may only become available after the car's launch on the market. Maserati reserves the right to modify colours, designs and technical features at any time and without forewarning. Official Maserati Dealers will be glad to provide further details and updates in this regard.



Stay in touch with Maserati by aligning the QR code with the camera of your smartphone or visiting [www.maserati.com](http://www.maserati.com)